



Australian Government

Australian Transport Safety Bureau

PAST PRESENT FUTURE

THE AUSTRALIAN TRANSPORT SAFETY BUREAU



The strength of the ATSB is its people



RAIL
CROSSING
SWAY



PAST PRESENT FUTURE

The Australian Transport Safety Bureau

Compiled with information from past and present staff of the ATSB, and its precursor organisations.

Photographs: ATSB, Geoff Comfort (page ii), Australasian Railway Association Inc. (page 51).

Design: 2B Advertising & Design

Edited by Richard Batt (richard.batt@atsb.gov.au)

COVER IMAGES



Air safety investigators at work.



Onsite safety is crucial.

ISBN: 978-1-921095-87-0

Publication number: INFRA-08545

Published by the Australian Transport Safety Bureau © Commonwealth of Australia 2009

This work is copyright. Apart from any use as permitted under the *Copyright Act 1968*, no part may be reproduced by any process without prior written permission from the Commonwealth. Requests and inquiries concerning reproduction and rights should be addressed to the Commonwealth Copyright Administration, Attorney-General's Department, Robert Garran Offices, National Circuit, Barton ACT 2600 or posted at <http://www.ag.gov.au/cca>

PAST PRESENT FUTURE

THE AUSTRALIAN TRANSPORT SAFETY BUREAU

This publication celebrates the ten-year anniversary of the formation of the Australian Transport Safety Bureau on 1 July 1999.

It is the story of the ATSB, and the earlier organisations that came together to form the ATSB a decade ago.



CONTENTS



INTRODUCTION. page ii

Message from The Honourable Anthony Albanese MP **ii**
Minister for Infrastructure, Transport, Regional
Development and Local Government

Introduction by Mr Martin Dolan **iii**
Chief Commissioner of the Australian Transport Safety Bureau



THE ATSB. page 1

The Australian Transport Safety Bureau **1**

Complementary strands **13**

The forensic approach **15**

The human touch **21**



INVESTIGATIONS. page 27

Aviation safety investigation **27**

Marine safety investigation **45**

Rail safety investigation **53**

Road safety initiatives **61**



OVER THE HORIZON. page 71

The international dimension **65**

Over the horizon **71**

Past Present Future website **73**



MESSAGE FROM THE HONOURABLE ANTHONY ALBANESE MP

Minister for Infrastructure, Transport, Regional Development and Local Government

I am delighted to release this landmark publication, *The Australian Transport Safety Bureau – Past Present Future*. This publication outlines the outstanding professional reputation of the ATSB and its predecessors, and recognises their significant contribution to transport safety over many years, both within Australia and in the international arena.

The ATSB has many achievements to be proud of. The Bureau's rigorous investigation and analysis of many significant accidents and serious incidents is a constant theme. The ATSB's professionalism reassures all Australians that it is a capable and credible agency, with committed staff who conduct their work in the best interests of the travelling public. Information about some of these significant investigations, including the findings and the resulting safety actions that were implemented, can be found in this publication.

The Bureau's ongoing commitment and contribution to the behavioural science of human factors is considered to be world class, and the ATSB has been a leader in this field over many years.

The Bureau's engagement and influence in the region, and across the globe, with respect to safety investigation standards is also recognised. Importantly, the ATSB's task of facilitating capacity building within its sister organisation in Indonesia continues and is a wonderful example of regional cooperation.

The ATSB's worldwide reputation for excellence as a transport safety investigator, based on its operational independence, objectivity, and technical competence, has ensured that it has received strong support from successive Governments. On 2 December 2008, the Rudd Government reaffirmed this support when I publicly released the Aviation Policy Green Paper. Together with a range of other important aviation reforms, I announced that the ATSB's independence would be further enhanced by making it a separate statutory agency

with a Commission structure, to take effect from 1 July 2009. While I have always had confidence in the ATSB's work, this additional measure will put its independence beyond doubt and facilitate improved interaction with the transport industry and other agencies.



I trust you will find this publication informative. Based on the ATSB's excellent track record in transport safety, I have every reason to believe the next phase in the ATSB's evolution will be at least as successful as its last.

Anthony Albanese

Minister for Infrastructure, Transport,
Regional Development and Local Government



INTRODUCTION BY MR MARTIN DOLAN

CHIEF COMMISSIONER OF THE AUSTRALIAN TRANSPORT SAFETY BUREAU

As the new Chief Commissioner of the ATSB, I welcome the opportunity this publication presents both to recognise the many achievements of the ATSB and to look forward to its future. There is much to be recognised: the ATSB has a proud and highly regarded track record – domestically and internationally – in improving transport safety through its investigations, reports and safety education activities. You have in front of you an illustrative sample of how that track record has been achieved and maintained.



The enhanced independence of the ATSB, highlighted by the establishment of our new Commission, marks another major milestone in its history but at the same time recognises what remains to be done in transport safety investigation. It is also a privilege that the ATSB and its commissioners value and respect. We understand that the authority and powers of an independent safety investigator are given in the public interest: to ensure that when things go wrong in transport safety, the contributing factors and safety issues are understood and the necessary safety improvements are made.

From its foundation in aviation safety investigations, the ATSB has expanded into a broader transport safety role in marine and rail. Its undoubted capabilities in these modes will need to be maintained and may even need to be expanded to support the requirements of cooperative transport safety agreements among the States, Territories and Commonwealth.

We also face a future in the transport sectors where technology – and how people interact with it – will continue to evolve. The assessment and control of safety risks will need to evolve in parallel. The ATSB's consistent emphasis on analysing and communicating the human factors that are fundamental to achieving safety outcomes, equips it well to contribute in that changing environment.

In responding to its future challenges, the ATSB will maintain its focus on improving transport safety through rigorous investigation, through cogent communication of safety issues and the facilitation of safety actions, and through the dissemination of safety advice and effective education. I am proud to lead such a competent and professional organisation and to support the continued work of its staff.

Martin Dolan
Chief Commissioner of the
Australian Transport Safety Bureau



THE AUSTRALIAN TRANSPORT SAFETY BUREAU

This publication celebrates the ten-year anniversary of the formation of the Australian Transport Safety Bureau (ATSB) on 1 July 1999. It is the story of the ATSB, and the earlier organisations that came together to form the ATSB a decade ago.



A noble purpose

The ATSB is Australia's prime agency for transport safety investigations. The ATSB's objective is safe transport.

The ATSB investigates accidents and incidents to prevent the occurrence of future accidents, and not for the purposes of apportioning blame or liability.

As well as carrying out independent investigations of transport safety occurrences, the ATSB also conducts safety research and analysis and has a role in fostering safety awareness, knowledge and action.

On 1 July 2009, the ATSB became a separate statutory agency governed by a Commission, entirely separate from transport regulators, service providers, and policy makers.

“a proud history”

The ATSB was formed on 1 July 1999 from the amalgamation of the Bureau of Air Safety Investigation (BASI), the Marine Incident Investigation Unit (MIIU), and non-regulatory parts of the Federal Office of Road Safety (FORS). In addition, an embryonic Rail Safety investigation capability was established.

As this publication shows, each of the bodies that formed the ATSB already had a well-established record for excellence in their respective fields.

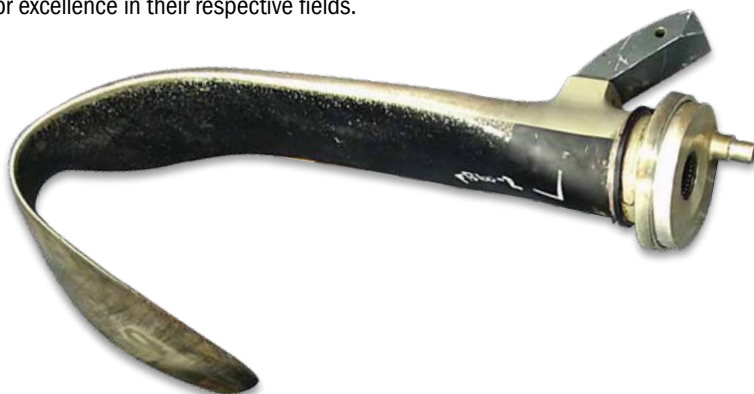

The strength of the ATSB is its people

The staff of the ATSB are a small group of highly committed professionals, working together with a strong common purpose – to improve safety. The work of the ATSB is very much a team effort, on the part of aviation, marine, and rail investigators, as well as other ATSB staff.

About 65 of the ATSB staff are transport safety investigators. They come from a range of professional backgrounds, including pilots, Licensed Aircraft Maintenance Engineers, air traffic controllers, master mariners, human factors specialists, and a range of engineering and technical disciplines.

“accidents can happen anytime and anywhere”

A day in the office

It's not every job where your work day can begin by being winched down from a helicopter to a remote accident site or climbing precariously up a ladder in a pitching sea, but sometimes that is how a transport safety investigator starts their day.





“honesty and integrity are crucial”

Accidents can happen anytime and anywhere. An accident site might be in a built-up area, a remote part of the outback, or somewhere off the Australian coast. Conditions can vary from very hot to very cold.

Bob Kells is a senior air safety investigator. His speciality is that of Licensed Aircraft Maintenance Engineer (LAME). He has been an investigator for over 20 years.

Like most of his ATSB colleagues, Bob previously held senior positions in his profession. He was the Chief Engineer for Hawker Pacific in Darwin, and later a Senior Airworthiness Surveyor with the then Civil Aviation Authority, before becoming an investigator in 1988.

Bob, what is the job of an investigator like?

Well, to start with it's extremely varied. Some of it involves working on accident sites, but that is just the beginning. In many ways, that's the easy part. Analysing what happened, and why, and putting that all together in an investigation report that a non-aviation person can easily understand, that takes quite some effort.

What qualities do you think make a good investigator?

Well, firstly, honesty and integrity are crucial, and of course operational and technical knowledge is essential. But there's more to it than that. You might not think it, but an investigator's people-skills are one of the most important aspects. They must be a good communicator, and negotiator, able to handle significant people-related issues such as dealing with bereaved families in a professional but understanding way.

After the technical aspects of an investigation have been completed, and all of the evidence has been analysed, the investigator must be able to write a report that clearly communicates the safety message. That's how safety will be improved.

Resourcefulness is another very important quality. You might be in a remote location and only have what is on hand locally to get the job done.

“It's a great feeling to know that you have made a difference”

The ATSB has strong powers to investigate. Those powers include the authority to access and control accident sites, to interview relevant personnel, and to obtain documentation and other material. The strength of those powers ensures that the ATSB can effectively and efficiently carry out its role.







Bob elaborates:

The ATSB is strongly independent. If it wasn't, it just wouldn't be a credible organisation. It would lose the respect and trust of the industry, and that would affect safety. People would be less likely to talk openly to us.

At times, investigators need the strength to stand up to pressure, wherever it might come from. The pressure might come from a crew member, or the aircraft operator or manufacturer, or even another government agency. We must be able to carry out our work without fear or favour.

Why do you think the ATSB is such a dedicated and close-knit group?

Well, I think it is a range of factors. For many, being an investigator has been a long term goal. They've done well in their profession, say as a pilot or engineer, but they've always had a passion for safety. So they are keen to go that next step. It's not the sort of job people just drift into.

Also, it's often said that adversity builds a common bond. Sometimes we're working in difficult circumstances, you really do have to rely on each other, not only for different technical skills, but sometimes for personal safety. Accident sites can be dangerous places. There can be lots of hazards, from the wreckage, sometimes just the location itself. I remember one time the slope was so steep, we had to be secured by a harness that was tied to a tree. But at the end of the day, the job can be very rewarding.

It's a great feeling to know that you have made a difference.



“teamwork is everything”



The legal framework

The ATSB conducts its investigations under a specific Act of Parliament, the *Transport Safety Investigation Act 2003*.

The information that the ATSB collects during an investigation can come from many sources – for example, interviews, documentation, and recorders like the aircraft ‘black boxes’.

“The *Transport Safety Investigation Act* gives the ATSB strong powers, both to collect information, and then to protect it.”

Having access to all relevant information is crucial if a safety investigation is to determine the factors that may have contributed to an accident or incident. The *Transport Safety Investigation Act* gives the ATSB strong powers, both to collect information, and then to protect it.

The reason people freely provide information to the ATSB is because they know the ATSB only uses the information to improve safety, and that the *Transport Safety Investigation Act* affords very strong protection to the information they provide.

The powers of the *Transport Safety Investigation Act* are intentionally vested in the Chief Commissioner, or the Commission as a whole. This ensures that the ATSB is entirely independent of any external influence.

In Australian aviation, the *Transport Safety Investigation Act* gives legal force to the principles of independent ‘no blame’ investigations laid down in the International Civil Aviation Organization’s Annex 13, *Aircraft Accident and Incident Investigation*. Similar principles are followed in marine investigation, with the International Maritime Organization having recently approved the adoption of the *Marine Casualty Investigation Code*, in the creation of which the ATSB played an active role.

Legislation also provides for a regime of mandatory reporting. Mandatory reporting allows the ATSB to act as quickly as possible to preserve evidence and to identify any safety issues that led to an accident or incident. Commencing an investigation as soon as possible after the accident or incident can be vital for optimum safety outcomes.

All aviation accidents, serious incidents and incidents in Australia, and those involving Australian registered aircraft overseas, must be reported to the ATSB. In rail, only accidents and serious incidents involving operations on the interstate rail network must be reported. In marine, only accidents and serious incidents in Australia involving interstate and international shipping, and those involving Australian registered ships overseas, must be reported to the ATSB.

“independent ‘no blame’ investigations”



The ATSB also administers confidential reporting schemes in aviation and marine. Important principles of those schemes are that they are voluntary and that the identity of the reporter is protected. The schemes provide an important avenue for people to report a safety concern where they may fear reprisal or sanction if they report openly. In particular, for the aviation and marine industries, it provides another important source of safety intelligence that may lead to increased awareness and safety improvements.

“in confidence...”

Seeing the big picture

While the core business of the ATSB is the investigation of individual accidents and incidents, the full value of these individual investigations is only realised by taking a look at the bigger picture. The role of the ATSB's aviation safety research team is to do just that. The team delves into the substantial database held by the Bureau to identify important safety trends.

Over the years, BASI and the ATSB have developed an extensive library of research reports that have helped inform the aviation sector, both in Australia and overseas. In fact, the ATSB has developed an effective and systematic approach to aviation safety research that helps Australia fulfil its international obligations. ICAO Annex 13 places a clear responsibility on member countries to analyse information held in their accident and incident database. This kind of research and analysis is intended to give a stronger focus to preventative or proactive measures to enhance aviation safety.

“monitoring accident trends”



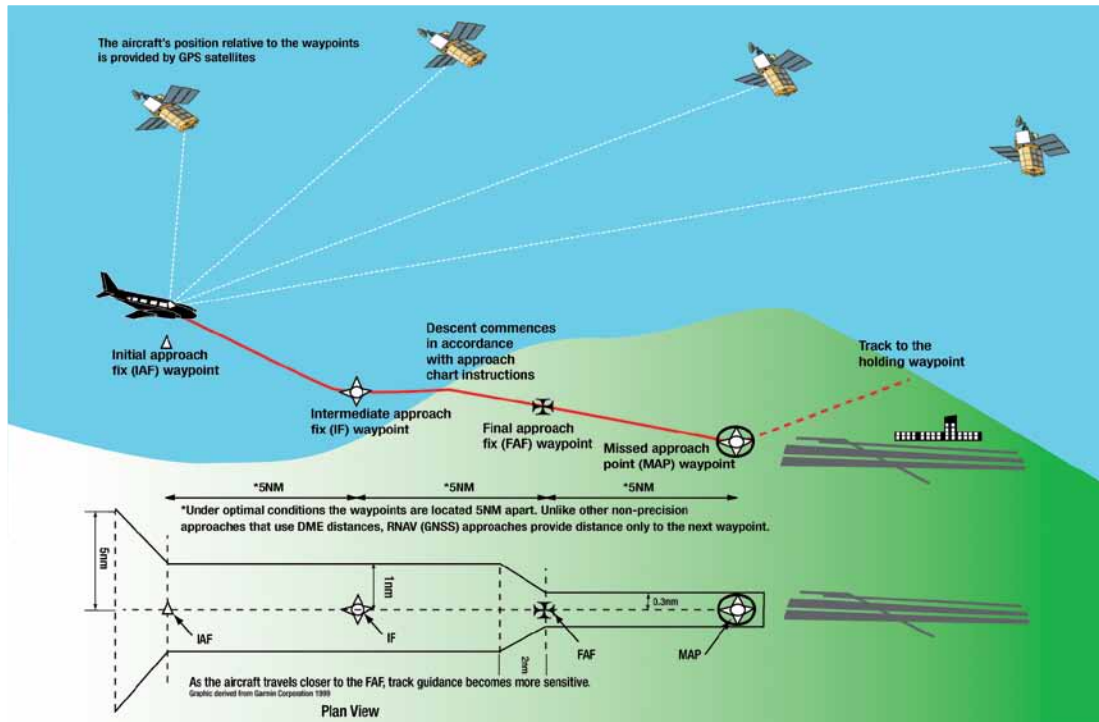

By examining larger sets of data, the ATSB is able to pick out trends or emerging issues, and bring these to the attention of the aviation regulator, industry groups, and interested members of the public. The aim is to provide relevant, timely and objective analysis that will enhance future aviation safety.

ATSB research has been used to benchmark Australia's safety record against that of similarly structured aviation markets, including Canada, New Zealand, the United Kingdom and the United States. Those studies have found that generally Australia performs at least as well across various types of operation, and that our high capacity passenger operations are especially safe.

Perhaps one of the most challenging aspects of aviation research in Australia is that because there are relatively few accidents, it can often be difficult to identify and monitor trends. Hence, the work of the research team is to keep a 'weather eye' open for accidents or incidents that might foreshadow the emergence of a more serious problem.

The ATSB publishes reports that provide meaningful insights for pilots, engineers and maintainers, air traffic controllers, and the wider community. Most aspects of aviation safety have international relevance, so the work of the ATSB's research program reaches beyond our shores. It is not uncommon for overseas agencies to use ATSB reports, including research reports, and many of the ATSB's research activities are reported widely among respected aviation journals and industry magazines.

So what does the future hold for aviation research? The data shows us that globally, aviation remains the safest form of mass transport, and that accident rates have been falling consistently. However, it would be a mistake to assume there is little left in terms of future improvements. Research is one of the tools available to us to develop a better understanding of the new challenges and the strategies to deal with them.



GA accident rates, 2002 to 2006

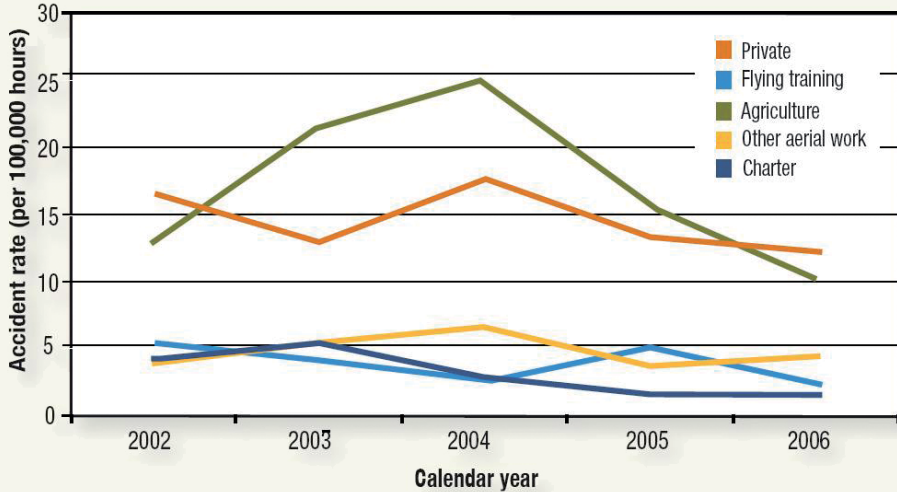

Getting the safety message out

Conducting a transport safety investigation is not an end in itself. Safety can only be enhanced if the results of ATSB investigations and safety analyses are made available to individuals, operators, regulators, and others who take safety action.

The ATSB prefers to encourage safety action by relevant parties in response to identified safety issues, and to acknowledge this action in its investigation reports. This negates the need to issue formal safety recommendations.

All investigation and research and analysis reports are made public on the ATSB's website (www.atsb.gov.au) as are any safety recommendations made by the ATSB. These are directed to regulators, manufacturers, operators and others urging them to address any outstanding safety issues that were not already proactively addressed during investigations.

ATSB reports have featured extensively in publications of the International Civil Aviation Organization and the Flight Safety Foundation.

The ATSB also publishes information about investigations and other safety matters in a range of industry publications, including an ATSB Supplement to the Civil Aviation Safety Authority's publication *Flight Safety Australia*.

ATSB investigators and other staff participate in industry forums, both in Australia and overseas. This includes giving presentations on the results of investigations and research and analysis, as well as educating others about how the ATSB conducts its investigations.





Credibility is everything

High quality training and development is vital to the success of any operationally focused organisation that relies on its credibility to effect positive safety outcomes. The Bureau's training and development system is widely regarded as today's industry best practice.

Investigation fundamentals

All new investigators complete the nationally accredited Diploma of Transport Safety Investigation. This qualification was established in 2002 and includes over 700 hours of structured development, and is purposely tailored to establish the fundamental skills and knowledge required to execute the full spectrum of investigative duties. This qualification was developed by a project team led by Kerryn Macaulay, the ATSB's then Director of Strategy and Capability and the then Deputy Director of Surface Safety, Kit Filor, PSM.

Maintenance of industry knowledge

In accordance with set work level standards, as an investigator's capability increases through experience and mentoring, it is equally important that they maintain their prior individual industry skills and knowledge. The ongoing ATSB commitment to this aspect of training ensures that investigation staff remain abreast of industry practices and changes.

“world class investigator training”

Professional mastery

With the completion of the Diploma of Transport Safety Investigation, and pathways for maintenance of industry skills and knowledge established, the next phase of capability development centres around further tertiary pursuits. This is a targeted approach that is aimed at developing professional mastery, for example, by a pilot completing a Bachelor of Aviation or an Aeronautical Engineer pursuing a Masters of Material Engineering.

As the ATSB Training and Development Manager, Colin McNamara, explains:

The ATSB's dedicated and formal approach to training and development ensures that staff are professionally qualified, current with industry practices, motivated, and present a high level of credibility.

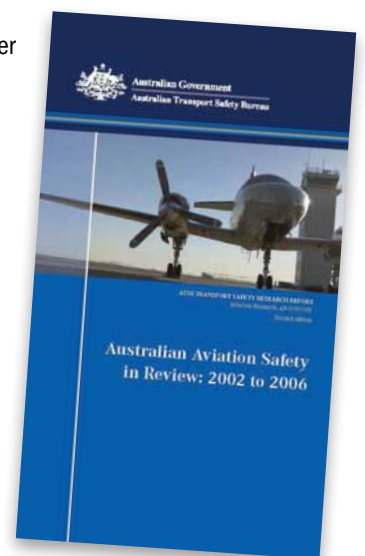

One endeavour that helps to keep investigators' skills primed is their involvement in major accident preparedness exercises. The ATSB plans and organises some of these exercises, while at other times it participates in exercises run by other authorities, such as major city aerodrome emergency response exercises.

“participation in major overseas investigations”

In addition, investigators at times take part in major overseas investigations as part of ongoing professional training, or at the request of the government of another country. ATSB investigators have observed or participated in overseas accidents including:

- TWA B747, after departing New York's JFK Airport, 1996
- Korean Air B747, Guam, 1997
- SilkAir B737, Palembang, Indonesia, 1997
- Egyptair B767, off the coast of Rhode Island, 1999
- Singapore Airlines B747, Taiwan, 2000
- American Airlines A300, near New York, 2001
- Lao Peoples Democratic Republic Ilyushin 76TD, Timor-Leste, 2003
- AdamAir B737, near Sulawesi, Indonesia, 2007
- Garuda B737, Yogyakarta, Indonesia, 2007

The ATSB also works cooperatively with its counterparts in the Australian Defence Force, and has assisted in the investigation of military aircraft accidents including the crash of an F-111C aircraft

near Guyra, NSW, on 13 September 1993, which took place during a night simulated attack, and the Sea King helicopter accident at Nias, Indonesia, on 2 April 2005, which occurred while supporting a humanitarian operation.

Some things change, some things stay the same

In order to stay at the 'top of its game', the ATSB has had to remain both vigilant and agile. The level of external scrutiny and the number of challenges to the ATSB's investigation processes and findings have increased. As in many walks of life, there are increasingly high expectations of the ATSB's work. There are also more instances where other parties attempt to refute or dilute the ATSB's safety message, for reasons other than transport safety.

The principles of independence and the protection of sensitive safety information in the interests of future safety have been firmly protected. These are internationally considered non-negotiable ingredients for a successful safety investigation agency. Accordingly, they underpin the *Transport Safety Investigation Act 2003*.

The ATSB's continuing acknowledgement that human fallibility requires transport systems to be error resistant and error tolerant remains a key feature of its investigation methodology.





However, rapid changes in technology in all modes of transport have necessitated both a change in the mix of investigation expertise required within the ATSB, and an increased focus and commitment to ongoing training for investigators to keep up with those changes. Such changes include satellite-based navigation systems, high-efficiency engines, increased use of composite materials for the construction of

transport vehicles, the introduction of glass cockpits, and the move from mechanical to fly-by-wire systems.

There have also been changes in the tools available to investigators – changes that have helped to improve the rigour of safety investigations. Accident site mapping can now be accomplished with the use of laser

scanners. The ability to forensically

examine a failed component has been made easier and quicker with improvements to electron scanning microscopy. Visual simulations developed using data from flight recorders serve as a powerful tool for the understanding and analysis of accident sequences.

“changing technology”

The final frontier

On 30 October 2001, a rocket launched from Woomera in northern South Australia malfunctioned and subsequently crashed. The accident involved the first HyShot rocket launch at Woomera. The launch was to test a University of Queensland ‘scramjet’ – a world-leading project in the race for faster passenger transport.

After the launch, the rocket’s first stage booster appeared to operate successfully, but when the second stage ignited the rocket started to ‘cork screw’ and departed from the planned trajectory. The second stage booster was found about 16 weeks later, over 250 kms from the nominal aiming point, and about 28 km east of the Stuart Highway.

The federal Industry Minister asked the ATSB to investigate the occurrence, under the *Space Activities Act*. The ATSB’s investigation found that a failure of the first-stage fins on the rocket, due to aerodynamic overloading, had resulted in an unstable flight. Risk analysis conducted before the launch allowed for failure of the rocket first stage and non-ignition of the second stage, but it did not cover the possibility of the rocket malfunctioning and veering off course.

The ATSB’s investigation, and its final report and recommendations, led to important changes before a reportedly highly successful second launch.

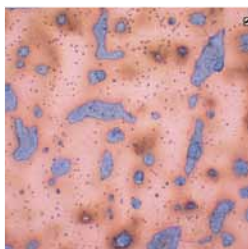
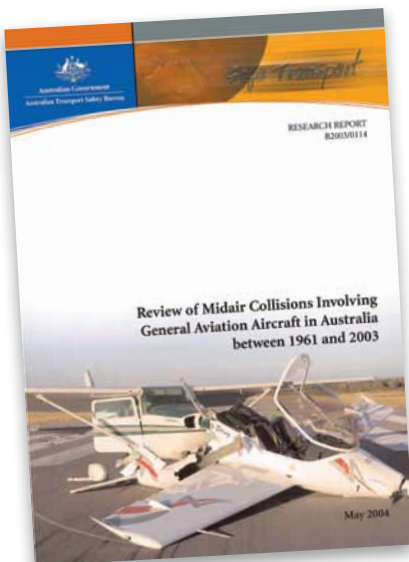



COMPLEMENTARY STRANDS

The ATSB, and its predecessor organisations, have excelled in technical analysis and human factors.

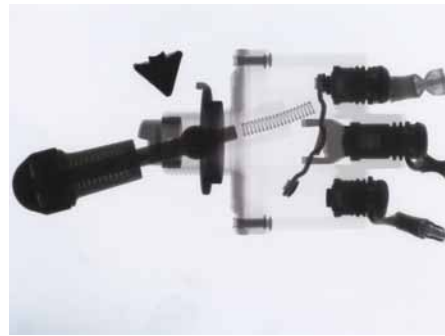

Technical analysis and human factors might seem quite disparate, but in fact they have much in common.

Technical analysis applies knowledge from the physical sciences in order to understand the capabilities and limitations of engineered systems. Human factors applies knowledge from the behavioural sciences in order to understand the capabilities and limitations of human performance. Together, they can provide a highly detailed portrait of what lead to an accident or incident.

Technical analysis and human factors are both fundamental to best practice in transport safety investigation. Importantly, they are both evidence based. That is, they reach conclusions based solely on a rigorous analysis of the data, not on conjecture. They are the complementary strands of a professional transport safety investigation.

Over the decades, Australia has made a number of world class contributions in the application of both technical analysis and human factors to transport safety.

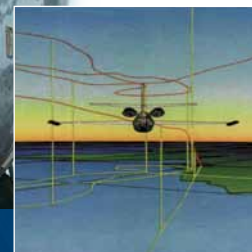



THE FORENSIC APPROACH

The role of the ATSB Technical Analysis section is to apply engineering science to transport safety investigations. In particular, the Technical Analysis section has the capability to examine the physical and recorded evidence from aviation, rail, and marine accidents and incidents. Physical evidence includes things like vehicle wreckage, and recorded evidence includes information from on-board recording devices – often called ‘black boxes’.



Physical evidence

The ATSB’s technical facilities in Canberra include a materials examination laboratory and a scanning electron microscope facility to undertake materials failure analysis and the in-depth examination of physical evidence. The process begins with non-destructive techniques, such as examination under a high-powered microscope. If required, destructive techniques

can then be used. The final step, analysing and interpreting the data obtained, requires a high degree of skill and experience.

A fatal flaw

In 2003, the ATSB identified an in-service failure mode involving the main rotor blades of a type of light utility helicopter flown extensively throughout the world.

On 20 June 2003, at about 8.40 am, a Robinson R22 helicopter crashed in the Bankstown flying training area, fatally injuring the flight instructor and student pilot. Witnesses reported hearing a number of loud bangs and seeing what appeared to be a main rotor blade separating from the helicopter.

An examination of the main rotor blade in the ATSB Technical Analysis laboratories revealed that it had failed as a result of fatigue. The fatigue crack started at a bolt hole near the root of the blade and spread from the crack initiation point, reducing the strength of the blade to the extent that it failed under normal flight loads. The crack was hidden from view because there

was an area of adhesive disbonding between the main rotor blade skin and the blade root fitting. The disbonding also allowed the ingress of moisture which resulted in pitting and helped initiate the fatigue cracking.

As a result of its investigation, the ATSB issued safety recommendations to the United States Federal Aviation Administration and to the Robinson Helicopter Company. The manufacturer subsequently issued a bulletin that required all blades of that model be withdrawn from service within the next six to twelve months, depending on the serial number. The manufacturer also introduced a redesigned main rotor blade into service.

Cause-and-effect diagram for plain bearing insert movement

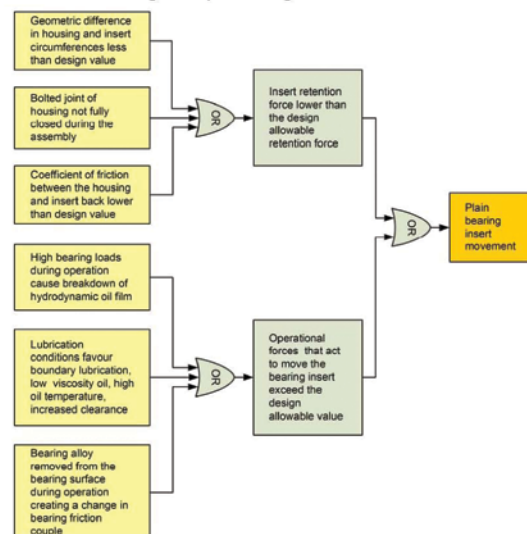



When things fly apart

On 8 December 2002, a Boeing 767 aircraft flying from Brisbane to Auckland, New Zealand, sustained an uncontained engine failure shortly after leaving Brisbane. Failure of the engine (a General Electric CF6-80A high-bypass turbofan engine) resulted from the fracture of the first-stage high-pressure turbine disk. ATSB laboratory examination found that the disk cracking had originated in an area that had sustained heavy surface micro-structural damage as a product of manufacturing and/or repair processes.

As a result of the findings of the investigation, the engine manufacturer implemented changes to the manufacturing and repair processes, to avoid the surface damage found on the failed disk. The US Federal Aviation Administration and the Australian Civil Aviation Safety Authority subsequently mandated the revised requirements.

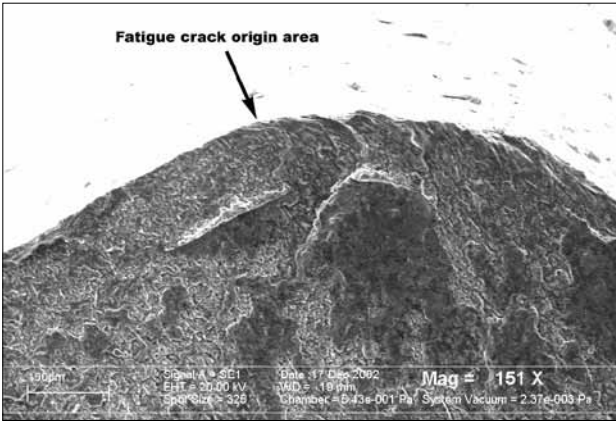

A long shot

On 5 February 2007, a Cirrus SR22 aircraft lost power during a flight from Canberra to Bankstown due to a mechanical fault. The aircraft forced landed near the M7 motorway and both occupants sustained serious injuries. Prior to impact, the pilot activated the Cirrus Airframe Parachute System (CAPS), but the system malfunctioned and the parachute did not deploy. As a result of the ATSB investigation, the aircraft manufacturer issued an Alert Service Bulletin incorporating design changes to the CAPS in the worldwide fleet of Cirrus aircraft.

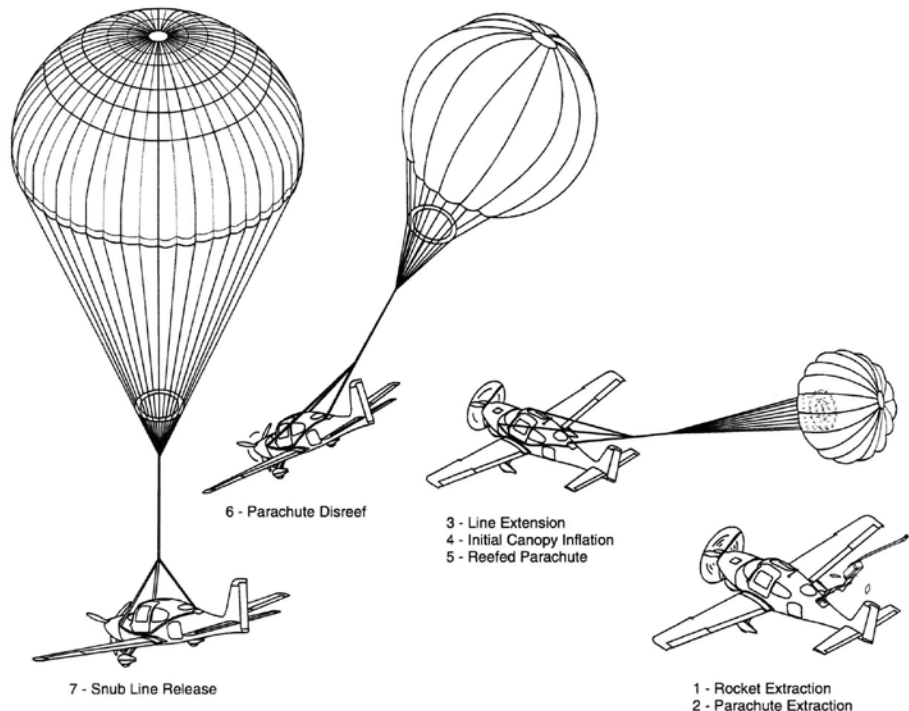

Recorded evidence

The ATSB is one of the few investigation authorities in the region with the facilities and expertise to recover and analyse data from transport vehicle recorders such as aircraft flight data recorders (FDRs) and cockpit voice recorders (CVRs). This regional 'centre of excellence' assists overseas authorities with their investigation of major accidents.

Other sources of recorded data include, rail and marine data recorders, ground-based radar recorders, and air traffic control communications tapes. Sometimes, the recorders may be the only means of determining what happened during the accident sequence.



Strange perturbations

On 1 August 2005, the crew of a Boeing 777 passenger aircraft flying from Perth Australia to Kuala Lumpur, Malaysia, observed a series of unexpected and unlikely readings on the aircraft's flight instruments. At various times, the instruments suggested that the aircraft's speed had significantly decreased, that the aircraft was slipping to the right, and even that the aircraft was approaching both the overspeed limit and the stall speed limit at the same time.

During the time that the flight instruments were misreading, the aircraft climbed and descended by several thousand feet. However, the crew were able to maintain control of the aircraft and the flight returned to Perth.

Information from the flight data recorder indicated that, at the time of the occurrence, unusual acceleration values were recorded in all three planes of movement. The acceleration values were provided by the air data inertial reference unit (ADIRU) to the aircraft's primary flight computer and autopilot.

Although the ADIRU was designed with system redundancy to prevent malfunctions from occurring, the investigation found that a fault existed in the ADIRU software that allowed inputs from a known faulty accelerometer to be processed by the ADIRU and used by the autopilot.

Based on the ATSB investigation, the ADIRU manufacturer developed a new version of the software to remove the fault. The aircraft manufacturer and airline operator produced amended procedures to deal with a failure of the ADIRU.

“a regional centre of excellence”

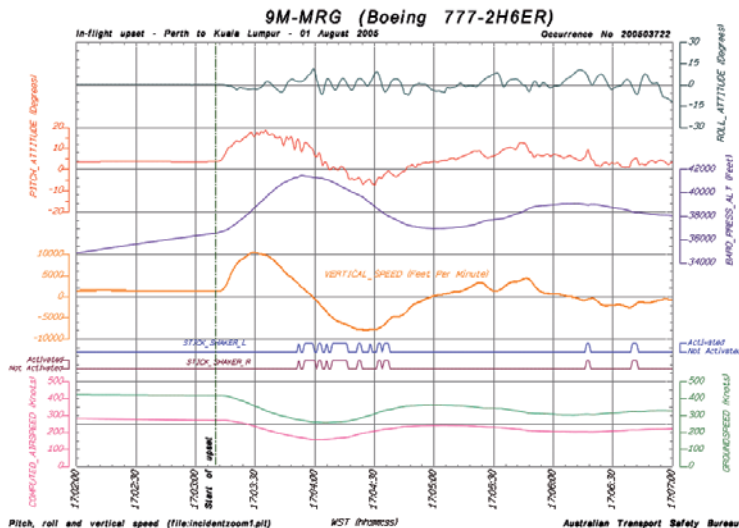

Mr Kym Bills

Kym Bills was the foundation Executive Director of the newly formed Australian Transport Safety Bureau from 1 July 1999, and gave strong leadership to the ATSB during its first decade.

During his time as Executive Director, Kym's consistent goal was excellence – to make the ATSB the best multi-modal safety body in the world and to expand its reputation and scope to maximise its impact on future safety.

Before being asked to lead the ATSB, Kym was head of the then Transport Department's Maritime Division from September 1994. His responsibilities in that position included a role in maritime policy and financial assistance programs, oversight of the Marine Incident Investigation Unit, chairing the Commonwealth/State Marine and Ports Group, and board memberships of ANL Limited and the Australian Maritime Safety Authority.

Early in his tenure as ATSB Executive Director, Kym faced a number of challenges. As he outlines,

The report of the ATSB investigation into the safety of the Class G Airspace trial was released in November 1999. It was critical of the regulator, and the Chairman at the time. That caused some angst. Also, there was a lot of public and media interest in the investigation into the September 1999 Qantas runway overshoot accident in Bangkok, that the Thai authorities delegated to the ATSB.



www.geoffcomfort.com

During Kym's tenure, many reports by the ATSB made a major contribution to transport safety. Some involved controversy and tested the perceived independence of the ATSB. Kym argued that the ATSB should be a statutory agency in accordance with international best practice.

From 1999 to March 2008 Kym chaired the National Road Safety Strategy Panel. The ATSB also coordinated the National Road Safety Strategy for 2001–2010, including maintaining national road safety databases, and producing research and statistical reports. During that time significant progress was made in road safety.





A major milestone during Kym's time as Executive Director was the development and introduction of the *Transport Safety Investigation Act*. The TSI Act was enacted on 1 July 2003 and incorporated rail as well as the already established aviation and marine functions. The TSI Act strengthened the ATSB power's to investigate aviation, rail, and marine occurrences, while at the same giving greater protection to information obtained during the course of an investigation.

Under Kym Bills' leadership, the ATSB set new standards in areas such as investigator training and safety analysis methodology. A competency-based nationally accredited Diploma of Transport Investigation was established, and the introduction of the Safety Investigation Information Management System – SIIMS – formalised best practice in transport safety investigation.

Proud of the professional staff of the ATSB, Kym consistently championed their role and defended them when unfairly criticised, as sometimes occurred in the

heat of coronial inquests or when involved parties to an accident or incident did not accept the existence of, or responsibility for, safety issues attributed to them.

Kym is a fellow of the Chartered Institute of Logistics and Transport and of the Safety Institute of Australia, and was chair of the International Transportation Safety Association in 2006 and 2007. In 2005, Kym was appointed as head of the secretariat for the Review of Airport Security and Policing headed by the Rt Hon Sir John Wheeler. In January 2009, Kym was appointed by the Hon Martin Ferguson AM MP to review Australia's offshore petroleum industry regulation in light of a gas pipeline explosion in 2008 at Varanus Island that cut 30 per cent of Western Australia's gas supply at a cost of around \$3 billion.

Kym left the ATSB on 1 July 2009 as it became a statutory agency led by Commissioners, confident of its future as a force for improving transport safety in Australia and beyond.

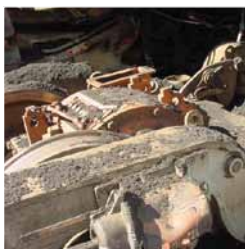



THE HUMAN TOUCH

Human Factors is the multi-disciplinary science that applies knowledge about the capabilities and limitations of human performance to all aspects of the design, manufacture, operation, and maintenance of products and systems.

The Bureau of Air Safety Investigation (BASI), and later the ATSB, have a long and proud tradition of promoting the investigation of human factors in aviation and other transport modes, an approach that is crucial to improving safety.

“not just *what* happened, but *how* and *why* it happened”

After any accident or incident, an initial operational and technical investigation is essential to determine *what* happened during the occurrence. However, very often, it is only by investigating the possible role of human factors at both the individual and organisational levels that it can be determined *how* and *why* the accident or incident occurred. Only with that more complete understanding can appropriate safety action be taken.

Leading the world

In 1983, BASI recruited an applied psychologist as its first human performance specialist, as the position was then termed. The Bureau was one of the world's first civil air safety investigation organisations to do this. Two additional human factors staff were soon appointed, and this core team established and developed BASI's capability in human factors, systems safety, and research. They were instrumental in fostering the role of human factors in Australian aviation safety, a legacy that remains to this day.

Early initiatives taken by BASI ensured that Australia was at the forefront of thinking in investigating human and organisational factors. For example, in 1986, BASI brought Roger Green, then Head of Aviation Psychology at the RAF Institute of Aviation Medicine, to Australia for a 6-week lecture tour. Similarly, in 1991 BASI brought Professor James Reason, a research psychologist from the University of Manchester, to speak in Australia. Work by James Reason was pivotal in laying the foundation for the modern approach to safety in aviation and other transport modes.

By the mid 1980s, BASI was including regular human factors articles in the air safety magazine *Aviation Safety Digest* that it produced for pilots and other aviation personnel. In 1986, BASI published a special edition of the digest titled *The Human Factor*. This edition covered a wide range of human factors topics, including information processing, decision making, ergonomics, stress, and aviation medicine.

In 1988, the Bureau established the Confidential Aviation Incident Reporting scheme (CAIR). This was an important milestone in Australian aviation safety. While complementing the mandatory scheme already in place in Australia, CAIR was initially introduced to capture richer information about the role of flight crew performance in incidents. The scope of CAIR was later expanded to accept reports from all areas of the aviation industry.

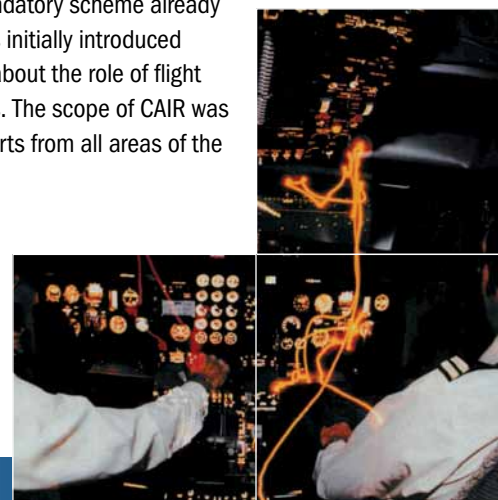
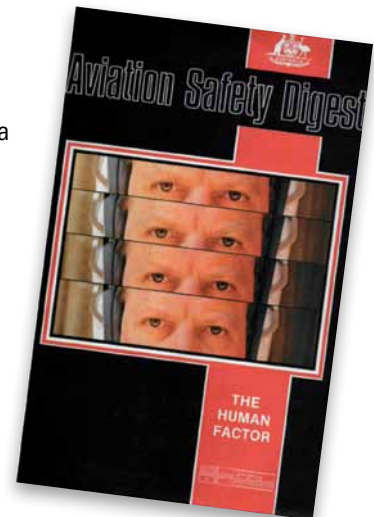

A



B



Another first, and another...

In 1989, BASI became the first air safety investigation organisation to have as its head a human factors specialist. This appointment moved the Bureau to concentrate on proactive accident prevention and safety enhancement as well as core accident investigation.

By the mid-1990s, all BASI investigators received human factors awareness training as part of their professional development. This in-house human factors training continues to this day, and is also made available to personnel from civil and military aviation, and from other transport modes, both within Australia and overseas.

BASI was the first civil aviation accident investigation body in the world to incorporate the formal and structured analysis of human and organisational factors into standard investigation methodology. In February 1993, BASI published the report of an investigation into a near collision between a DC-10 aircraft and an A320 aircraft conducting SIMOPS (simultaneous operations procedures) at Sydney Airport on 12 August 1991. This report outlined the 'Reason Analytical Model' and used concepts derived from the model to highlight the role of systemic factors in the development of the occurrence.

Three other BASI reports set the standard for the investigation and analysis of human and organisational factors. In July 1994, BASI published the report of the controlled-flight-into-terrain crash of Piper Chieftain aircraft VH-NDU at Young, NSW, on 1 June 1993.



This investigation highlighted the role of active and latent failures, local conditions, failed or absent defences, and organisational influences. In 1994, BASI published a major report titled *A Systemic Investigation of Airmis Occurrences*. This report, based on the new proactive and systemic approach to air safety investigation, resulted in major changes to airspace management in Australia.

“the fundamental limitations of human performance”

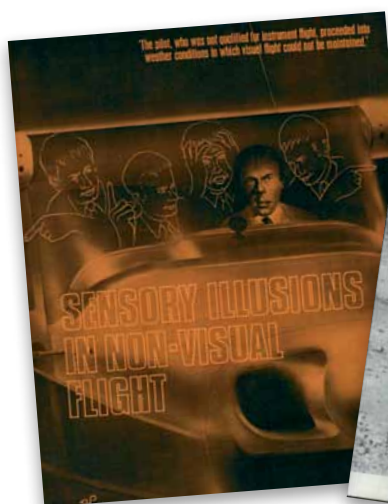



At the same time that BASI was developing modern methods of investigation analysis, it was also producing world-class research reports. Two such reports received The Chartered Institute of Transport in Australia's Qantas Award for Transport Excellence. The first report to receive this award was the *Limitations of the See-and-avoid Principle*, published in April 1991. The second report was the *Human Factors in Aircraft Maintenance* report, published in 1995.

Spreading the word

In the 1990s, BASI was highly influential in the adoption by ICAO of the requirement for air safety investigations to include an examination of relevant organisational and management aspects, using the Reason model of systems safety as a guide.

The expertise that BASI developed in investigating human and organisational factors during the 1980s and 1990s was later applied to the investigation of rail and marine accidents.

On 23 October 1997, two coal trains collided at Beresfield, NSW. Two BASI air safety investigators were seconded to the NSW Department of Transport to carry out the investigation into the accident, and the report was published in January 1998.



Many of the methods pioneered by BASI in the 1980s and 1990s are now considered standard practice by transport safety investigation bodies throughout the world. However, some investigation bodies in other countries have yet to implement the advances that BASI pioneered over two decades ago.



“systems safety”

0631:46 (63 km/hr)
Gradient now level

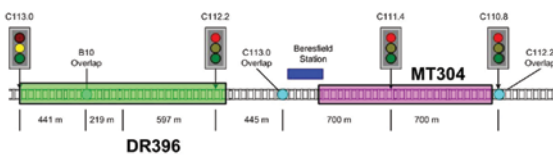

Continuous improvement

From its inception in July 1999, the ATSB has continued to develop and apply world-class methods of accident investigation and analysis in order to improve transport safety in Australian. This work culminated in the ATSB Safety Investigation Information Management System (SIIMS) project, introduced in 2007. The project team consisted of a range of subject matter experts and end users, primarily drawn from within the ATSB. The 4-year \$6.1 million project was achieved on-time and within budget. SIIMS provided a platform for all investigation activities and introduced a new level of standardisation and rigour to the collection and analysis of safety-related data.

“SIIMS investigation workspace”



The quality of a safety investigation’s analysis activities plays a critical role in determining whether the investigation is successful in enhancing safety. However, the development of investigation analysis methods has been a neglected area in most organisations that conduct safety investigations. The ATSB SIIMS system has introduced a rigorous analysis framework to be applied to all transport safety investigations. This approach is detailed in the 2008 ATSB publication *Analysis, Causality and Proof in Safety Investigations*.

“ATSB investigation model”

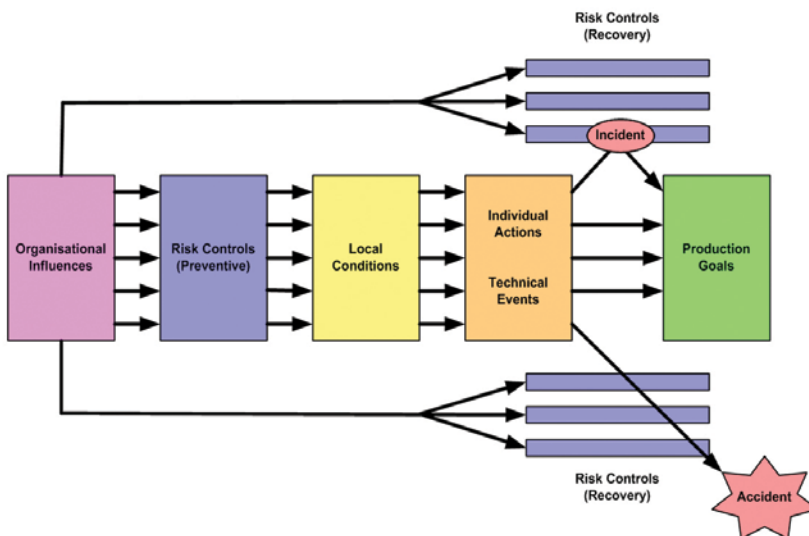



SGE

YCBR

SY 3

WLG

CNM

CBB

YWRN

YCAH

NRM

DU

MDC

PKS

CUA

SY 6

ORG

BTH

CWR

AVIATION SAFETY INVESTIGATION

The early days

The first civil aviation accident recorded by the Commonwealth of Australia occurred on 28 March 1921 and involved a Mono Avro aircraft. The pilot and one passenger were killed, and the other passenger received serious injuries. The accident report stated: 'Doubt as to cause, but suspicion of interference by passengers with pilot'.



In 1927, the Air Accident Investigation Committee was created to investigate all civil and military aircraft accidents that the Committee deemed advisable. Committee proceedings were not open to the public and interested parties did not participate in the proceedings other than as witnesses. The findings of the Committee were usually made public by the Minister through the press.

With the formation of the Department of Civil Aviation in 1938, following the loss of the DC 2 aircraft *Kyeema* near Mt Dandenong, Victoria, air safety investigation became the responsibility of the aviation regulatory authority within the Department. In the 1950s, a specialist Air Safety Investigation Branch was formed within the Department to carry out that role and a number of regional offices were established.

In 1982, the Air Safety Investigation Branch became the Bureau of Air Safety Investigation (BASI), with a Central Office based in Canberra and Field Offices in Sydney, Melbourne, Brisbane, Adelaide, and Perth. BASI was as an operationally independent unit of the Department of Aviation. When the Department of Aviation was abolished in 1987, BASI was transferred to the Department of Transport and Communications. On 1 July 1999, BASI became part of the multi-modal Australian Transport Safety Bureau.

Over the decades, BASI and ATSB investigations have made a significant contribution to aviation safety, not just within Australia, but also throughout the aviation industry worldwide.

Deadly icing

On 16 December 1988, a Mitsubishi MU-2B aircraft crashed on a pastoral property 55 km WNW of Leonora Airfield, WA. The pilot and nine passengers were killed and the aircraft was destroyed. The BASI investigation concluded that the aircraft probably accrued icing on the airframe during the climb, causing the airspeed to decrease to the point where the aircraft stalled and entered a spin.

On 26 January 1990, another Mitsubishi MU-2B aircraft crashed approximately 10 km NNE of Meekatharra, WA. The pilot and passenger were both killed and the aircraft was destroyed. Again, the BASI investigation concluded that the aircraft probably accrued icing on the airframe, causing the aircraft to stall and spin.





In both accidents, the pilot had not become aware of the decreasing airspeed in time to take action to prevent a loss of control.

“safety action worldwide”

BASI initiated a nationwide survey of MU-2 pilots and operators, requesting data about the aircraft’s handling characteristics in the upper levels of its flight regime. In 1992, BASI issued a combined report that included the investigations into the MU-2 crashes at Leonora and Meekatharra, as well as the results of the research study.

In 1996, the US Federal Aviation Administration issued airworthiness directives for the MU-2 aircraft type to mandate modifications to prevent icing-related accidents, and for icing awareness training for pilots.

On 11 November 1998, a Saab 340A turbo-propeller aircraft on a regular public transport service to

Melbourne, Vic, sustained an aerodynamic stall while in a holding pattern and lost 2,300 feet of altitude. The aircraft had accumulated a deposit of ice on the wings. The stall warning system of the aircraft did not provide the crew with a warning prior to the stall. The investigation also found a number of other occurrences involving Saab 340 aircraft where little or no stall warning had been provided to the crew while operating in icing conditions.

On 28 June 2002, a Saab 340B aircraft on a regular public transport service stalled on approach to Bathurst, NSW. The aircraft descended to within 112 feet above the ground. As in the 1998 occurrence, the investigation found that the aircraft stalled in icing conditions, prior to the stall warning system operating.

As a result of these two icing occurrences, the ATSB issued recommendations relating to the operation of the Saab 340 aircraft in icing conditions to airworthiness authorities worldwide.

On 2 January 2006, a Saab 340 aircraft on a scheduled transport service in the USA stalled while operating in icing conditions and lost approximately 5,000 feet of altitude. The US National Transportation Safety Board initiated an investigation into that occurrence and issued recommendations that cited the ATSB reports and recommendations. The NTSB report shared the same safety concerns expressed in the recommendations that had been issued by the ATSB.

As a result of these investigations, airworthiness directives have been issued covering the operation of the Saab 340 in icing conditions.



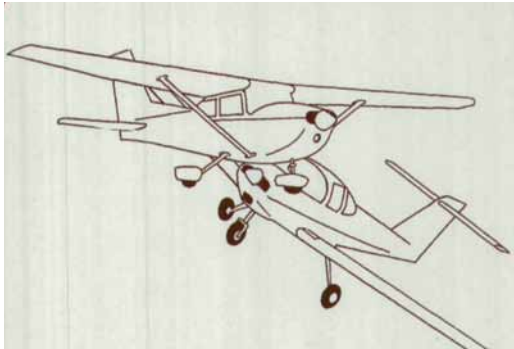

Keeping aircraft apart

The management of airspace – the procedures that pilots and air traffic controllers follow to ensure the safe separation of aircraft – can be a difficult and contentious issue.

On the afternoon of 20 May 1988, a Cessna 172 collided with a Piper Tomahawk in the circuit area at Coolangatta, Qld. The accident, in which four people died, occurred in conditions of good visibility.

The mid-air collision at Coolangatta, and others which occurred in the late 1980s, drew attention to the limitations of the see-and-avoid principle. See-and-avoid refers to a pilot using a continual out-of-the-cockpit visual scan to detect and avoid other aircraft.

As a result, BASI prepared a research report that evaluated the practicability of the see-and-avoid principle. First published in 1991, *Limitations of the see-and-avoid principle* was produced as a reference

document for the aviation industry. The report was reprinted in 2004, as the information it contained was still as pertinent as ever.

“see-and-avoid”

Following a number of airmiss occurrences in mid-1991, BASI began a major study into the safety of the Australian air traffic services system.

The methodology applied to this investigation reflected the new proactive and systemic approach taken by BASI, based on the work of Professor James Reason. The investigation found that, while the air traffic service system was safe, there were a number of systemic safety issues that needed to be addressed. For example, the structure of the system was fragmented, with little monitoring of the safety oversight of the overall system.

As a result of the BASI investigation, the Civil Aviation Authority introduced a number of changes to address the systemic safety issues identified in the report. A strategic planning unit was established, the quality assurance function was upgraded and strengthened, and human factors training was introduced for all air traffic services personnel.

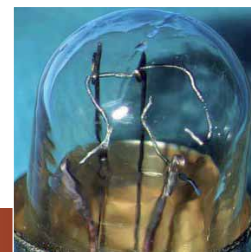
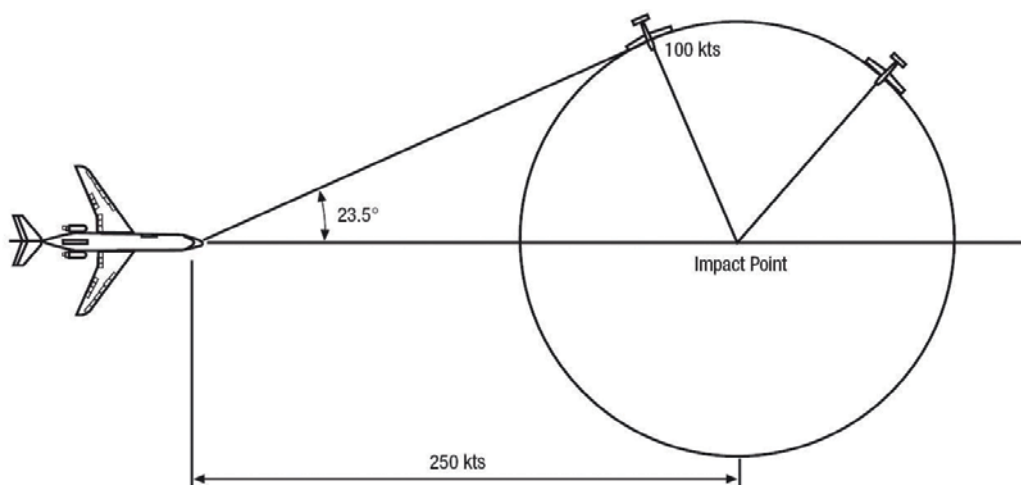

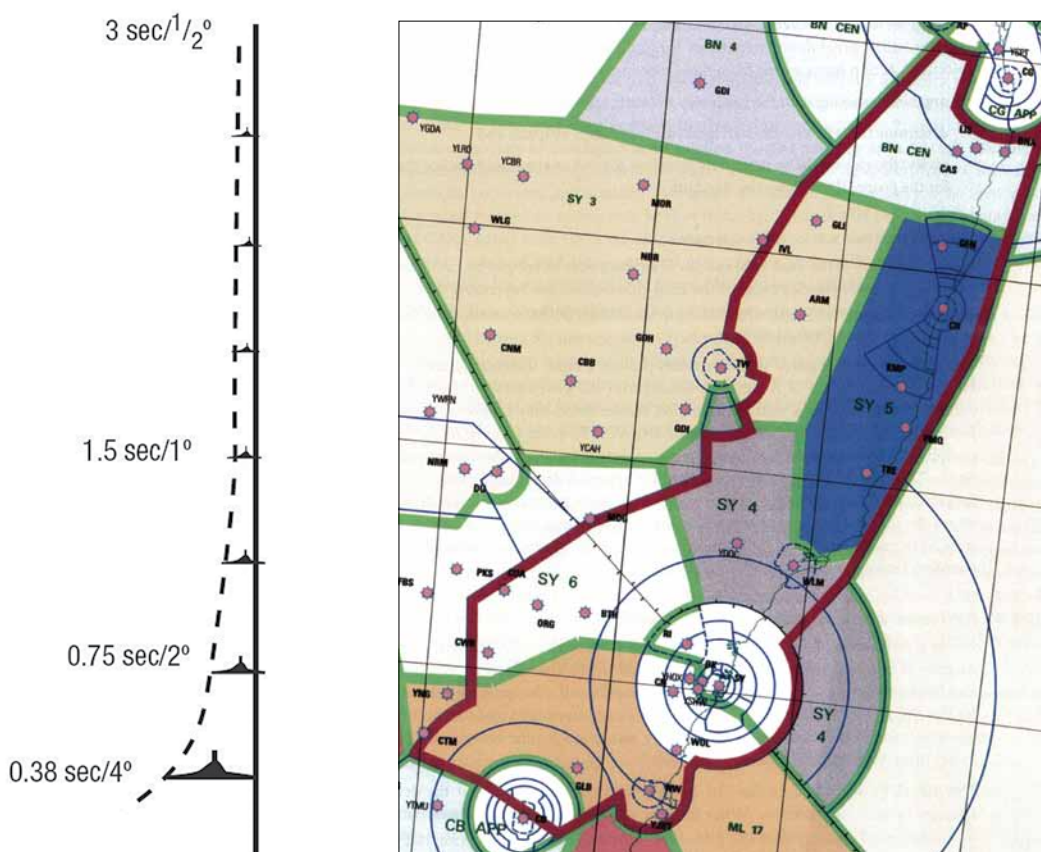

In 1998, the Civil Aviation Safety Authority implemented a trial of new procedures for aircraft operating in uncontrolled, or 'Class G', airspace. The trial, known as the 'Class G airspace demonstration', took place in the airspace between Canberra and Ballina, below 8,500 ft. It commenced on 22 October 1998. An end date was not specified – rather, it was intended that the new procedures would be extended throughout Australia in June 1999.

Following the receipt of over 70 air safety incident reports, BASI commenced an investigation into the development and operation of the Class G airspace demonstration. A number of safety issues that increased the risk to pilots were identified, and the demonstration was subsequently terminated on 13 December 1998.

As well as operational issues, the investigation addressed higher-level aspects such as the legislative framework and the Civil Aviation Safety Authority's program management of changes to the aviation system. The investigation also included a review of CASA corporate governance issues. How and when an investigation is broadened to include such organisational aspects is a complex and potentially contentious matter. However, it is important that, when appropriate, investigations do address such aspects. This is often the only way that safety improvements can be made.

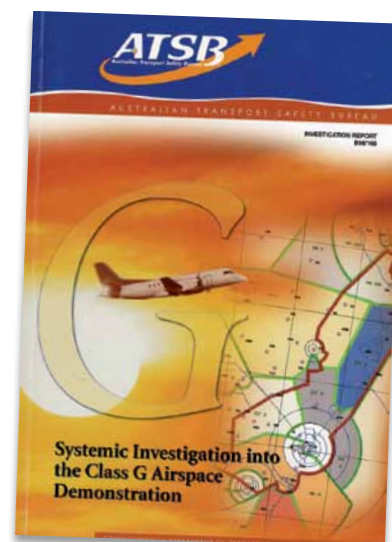

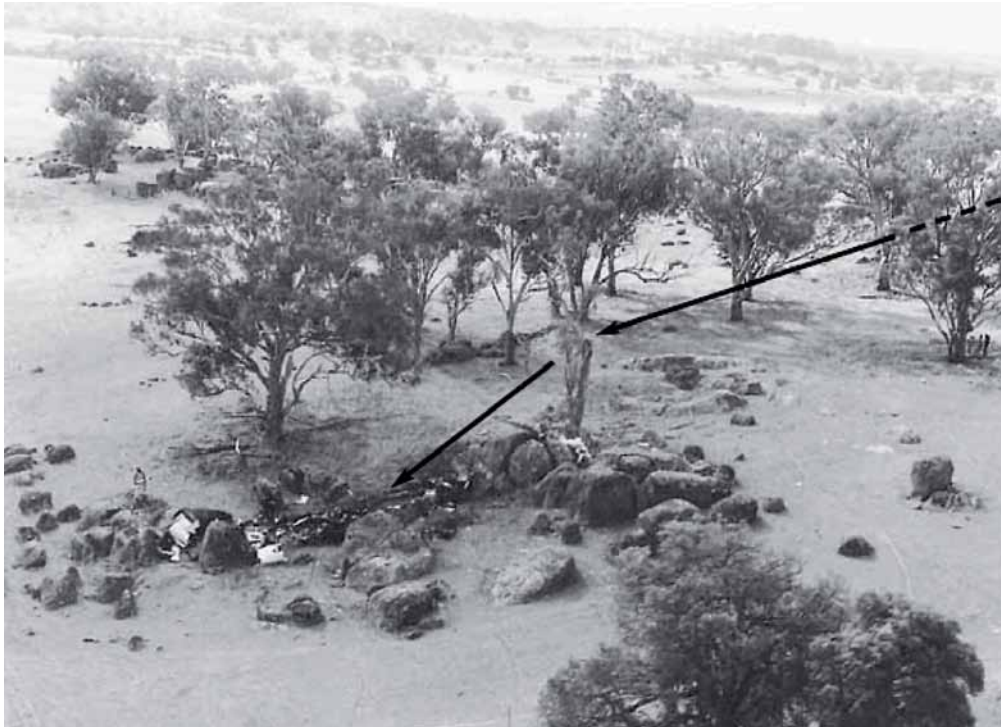

A dark and stormy night

On the evening of 11 June 1993, a Piper Chieftain aircraft operating as Monarch Airlines Flight OB301, crashed while on approach to land at Young, NSW. In conditions of low cloud and darkness, the aircraft struck trees at a height of 275 feet above the elevation of the aerodrome. The aircraft was destroyed by impact forces and a post-crash fire. All seven occupants, including the two pilots, suffered fatal injuries.

The investigation found that the circumstances of the accident were consistent with controlled flight into terrain. The culminating factor in the accident was that the crew flew the aircraft below the minimum circling altitude without adequate visual reference to the ground. However, a number of local conditions and organisational influences also contributed to the development of the accident. These included

aircraft equipment deficiencies, inadequate company procedures, and deficiencies in the regulation and licensing of the company's operations by the Civil Aviation Authority.

The findings and recommendations from this investigation provided the catalyst for a range of safety actions taken by the regulator. In particular, the practice of issuing 'open ended' Air Operators Certificates (AOCs) was ceased and replaced with specified periods, with AOC renewals based on an operator's previous performance and demonstrated capacity to continue to meet specified standards. An AOC holder's financial viability was also taken into account as an indicator of their ability to conduct safe operations. A review of the regulator's surveillance activities resulted in changes to a more proactive, risk-based approach.





Plane safe

In 1994, the House of Representatives Standing Committee on Transport, Communications and Infrastructure commenced an inquiry into the safety of general aviation and commuter airlines. In their report, published in 1995 and titled *Plane safe*, the committee found that ‘a paucity of information’ and ‘an absence of safety indicators’ were features of the low-capacity RPT sector of the Australian aviation industry. As an outcome of that report, BASI began an in-depth study of the regional airline industry.

The BASI report *Regional airlines safety study* examined all areas of regional airlines operations, including cabin safety, flight operations, maintenance, airspace management, regulations and surveillance. The study was conducted with the support of the industry and showed that, on the whole, the industry had a high regard for safety. However, it was found that in some airlines, commercial pressures were a significant factor in many identified safety issues.

Since the *Regional airlines safety study* was published in 1999, the regional airline industry in Australia has experienced a number of changes, both regulatory and operational. These changes, together with the Metro 23 accident at Lockhart River in May 2005, have prompted the ATSB to re-visit the issue of regional airline safety.

Never rest on your laurels

On the evening of 23 September 1999, a Qantas Boeing 747 operating as Flight QF1 from Sydney to London, overran the runway while landing at Bangkok, Thailand. Fortunately, none of the 410 people on board were seriously injured. After a couple of months of joint investigation, the Aircraft Accident Investigation Committee of Thailand formally delegated responsibility for the investigation of the accident to the ATSB.

The ATSB investigation found that the aircraft landed well beyond the normal touchdown zone and then aquaplaned on a runway that was affected by water following very heavy rain. The crew did not use reverse thrust during the landing. The captain ordered a precautionary evacuation of the aircraft about 20 minutes after it came to rest.

In releasing the report the ATSB’s Executive Director, Kym Bills, said that the QF1 accident was “a wake-up call to the Australian aviation industry that an excellent safety record must not be allowed to lull operators into a false sense of security”.

Like most major accidents, QF1 resulted from a complex mixture of human error, local conditions, inadequate risk controls and organisational influences. The Captain initially directed a go-around, but then changed that decision. Qantas had introduced new landing procedures without adequately considering all the possible safety implications of the changes.

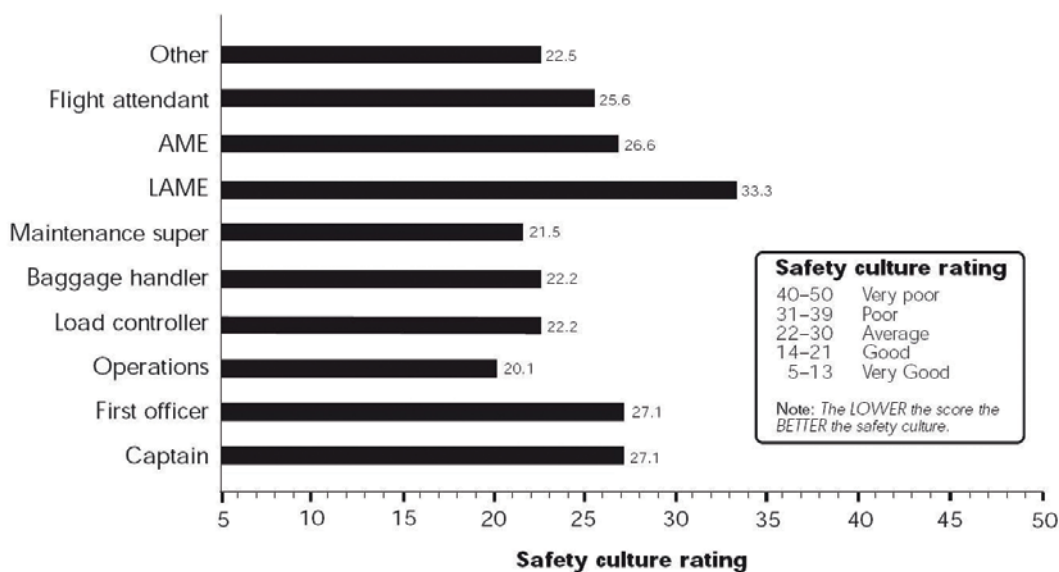

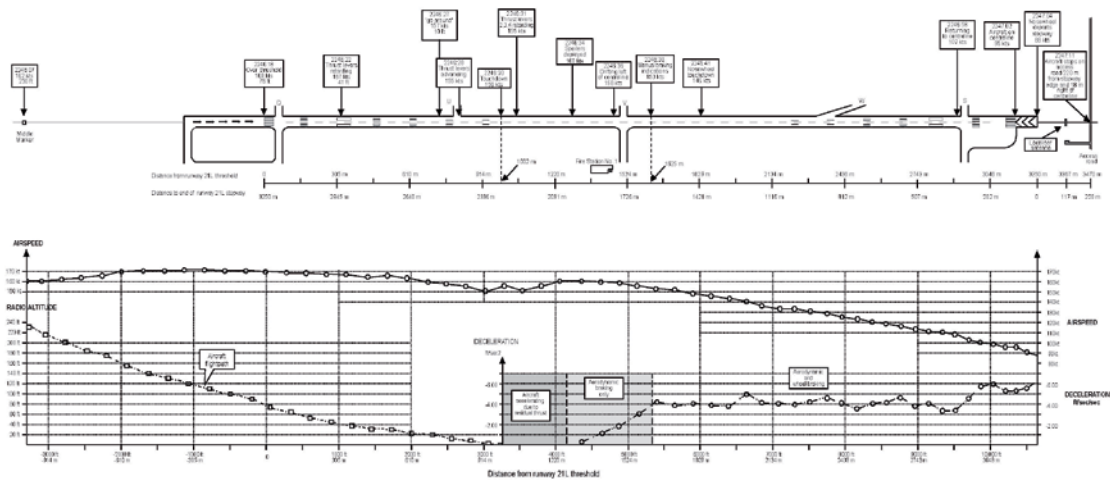

Regulations covering contaminated runways and emergency procedures were found to be deficient, as was regulatory surveillance of airline flight operations.

As a result of the ATSB QF1 investigation, Qantas and CASA made significant changes in the areas where safety issues were identified. Qantas updated the company flying manual with a comprehensive chapter covering issues relating to operations on contaminated runways, and CASA developed and implemented a systems-based surveillance audit program of operators.

Life jackets save lives

On the evening of 31 May 2000, a Piper Chieftain aircraft, operating as Whyalla Airlines Flight WW904 on a regular public transport service from Adelaide to Whyalla, SA ditched in Spencer Gulf after both engines failed. There was one pilot and seven passengers on board.

Early the following morning, a search and rescue operation located two bodies and a small amount of wreckage near the last reported position of the aircraft. The aircraft, together with five deceased occupants, was located several days later on the sea-bed. One passenger was not found.



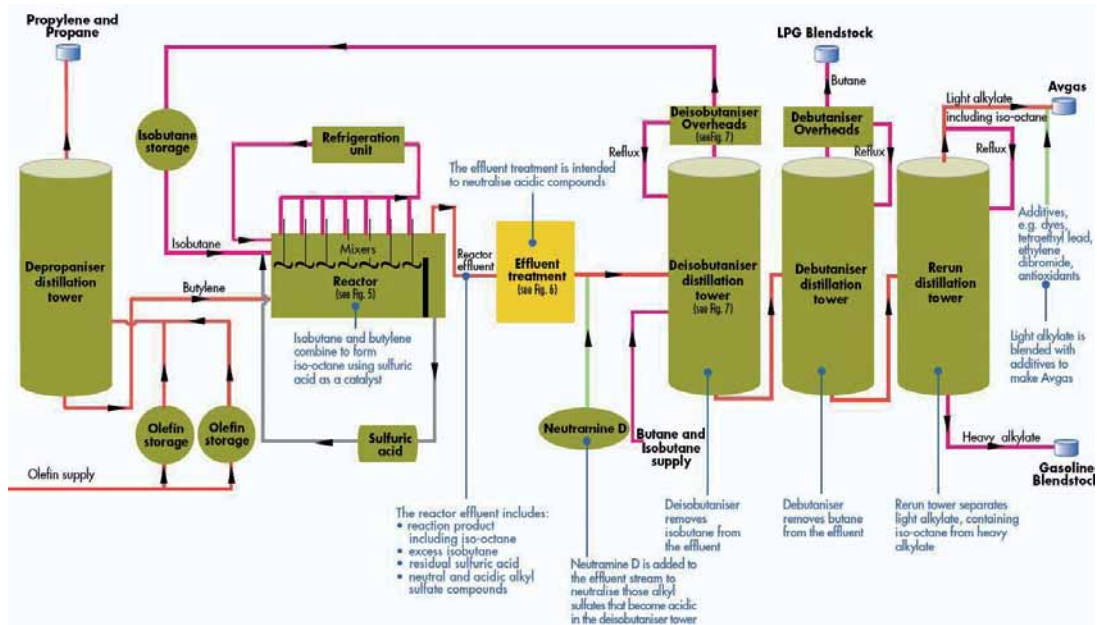

Both engines had malfunctioned due to the failure of components of the engines. The ATSB found that the crankshaft failed in the left engine due to a progressive fatigue crack. The pilot then probably over-boosted the right engine, resulting in piston damage and a loss of power. The South Australian Coroner later found the opposite failure sequence, which the ATSB rejected.

The Whyalla Airlines investigation highlighted a number of safety issues with wide applicability to low capacity air transport operations. The regulations at the time of the accident did not require the carriage of life jackets

on the flight. At least two of the occupants may have escaped from the aircraft after it ditched, but subsequently drowned. Had life jackets been available it is possible that their chances of survival would have been greatly increased. The ATSB recommended that, in future, life jackets be carried in similar circumstances. CASA agreed, and changed the relevant aviation regulations.

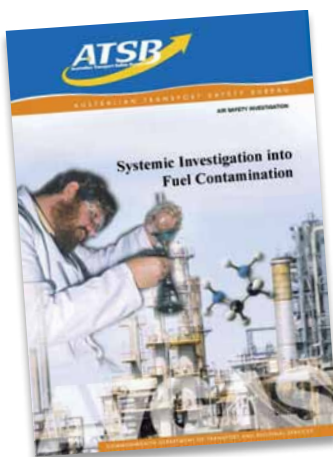

A nasty surprise

In January 2000, thousands of piston engine aircraft across eastern Australia were grounded when a black 'gunk' was found in light aircraft fuel systems. The problem first came to light when a student pilot on his second solo had an engine failure just after takeoff. Fortunately, he managed to land safely and stopped just short of the airfield perimeter fence.

The origin of the black deposits was found to be a contamination of the Avgas fuel by a very small amount of an anti-corrosion chemical that was not removed during the refining process, and then not detected by the usual tests.

The scale of the Avgas contamination was an unprecedented event worldwide, and was unexpected in such a mature industry as fuel refining. It had not been seriously considered as a potential hazard to aviation anywhere in the world. As a result, it caught the refiner and regulators by surprise and also revealed deficiencies in international fuel standards.

“gunk in the works”

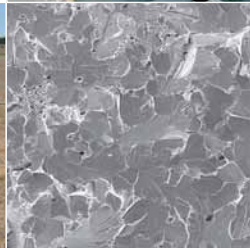



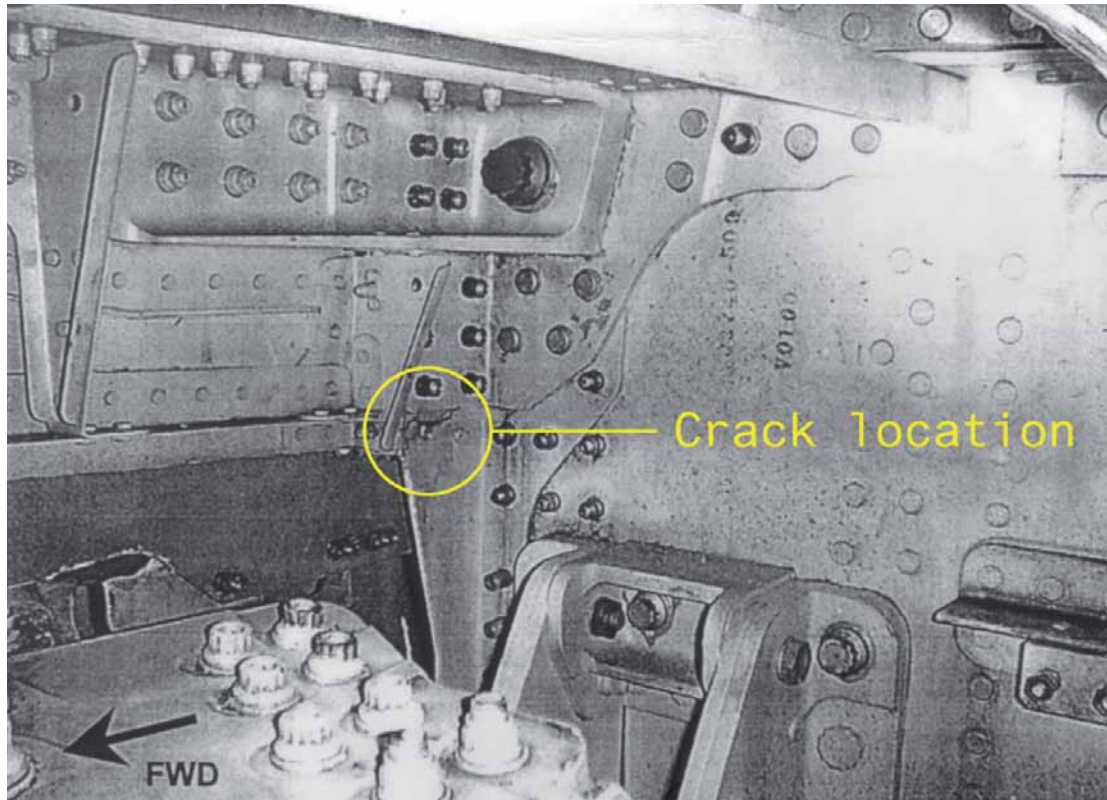

As a result of its investigation, the ATSB made recommendations for safety actions to Mobil Oil Australia, the US and UK fuel standards bodies, the Civil Aviation Safety Authority, and other Australian regulatory organisations.

The lessons learnt from the Avgas contamination investigation are equally applicable to other types of aviation fuel, including the fuel used in jet passenger aircraft. For example, as a result of the ATSB investigation, the UK fuel standard for jet fuel was modified to emphasise the need for adequate quality assurance when changes are made to the fuel refining process. Hence, the ATSB investigation had a global impact on the manufacture and distribution of aviation jet fuel.

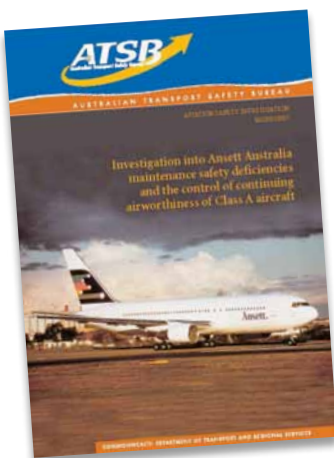

People and systems

In December 2000, Ansett Australia Boeing 767 aircraft were withdrawn from service when it was realised that required inspections for possible fatigue cracking in the rear fuselage of the aircraft had been missed. The aircraft were again grounded in April 2001, this time because of concerns related to possible fatigue cracking of the engine strut fitting on the wing front spar.

The groundings of the Ansett Boeing 767 fleet caught everyone by surprise. There was apparently little or no awareness within Ansett, or the Civil Aviation Safety Authority, of the underlying systemic problems that had developed within the Ansett engineering and maintenance organisation.



The subsequent ATSB investigation into Ansett maintenance safety deficiencies and continuing airworthiness issues found that, in addition to errors and omissions by individuals in Ansett, there were deeper system and resource weaknesses within Ansett and shortcomings associated with the US regulator of the aircraft type, the Federal Aviation Administration.

People and robust systems are two of the prime defences against error. The grounding of the Ansett 767 fleet demonstrated that a combination of poor systems and inadequate resources has the potential to compromise safety. If a failure by one or two individuals can result in a failure of the system as a whole, then the underlying problem is a deficient system, not simply human fallibility.

The Ansett 767 maintenance case highlighted the need for organisations to be continually mindful of potential threats to aviation safety, particularly when commercial pressures intensify and there are significant changes to organisational structures and the broader environment. This approach to safety is encapsulated in the concept of 'organisational mindfulness'. No system can guarantee safety for once and for all. Rather, it is necessary for an organisation to cultivate a state of continual unease, and always be alert to the possibility of system failure.

The ATSB investigation report into Ansett maintenance safety deficiencies and continuing airworthiness issues worldwide was awarded the international 2003 Flight Safety Foundation Brownlow Publication Award for a significant contribution to aviation safety awareness.

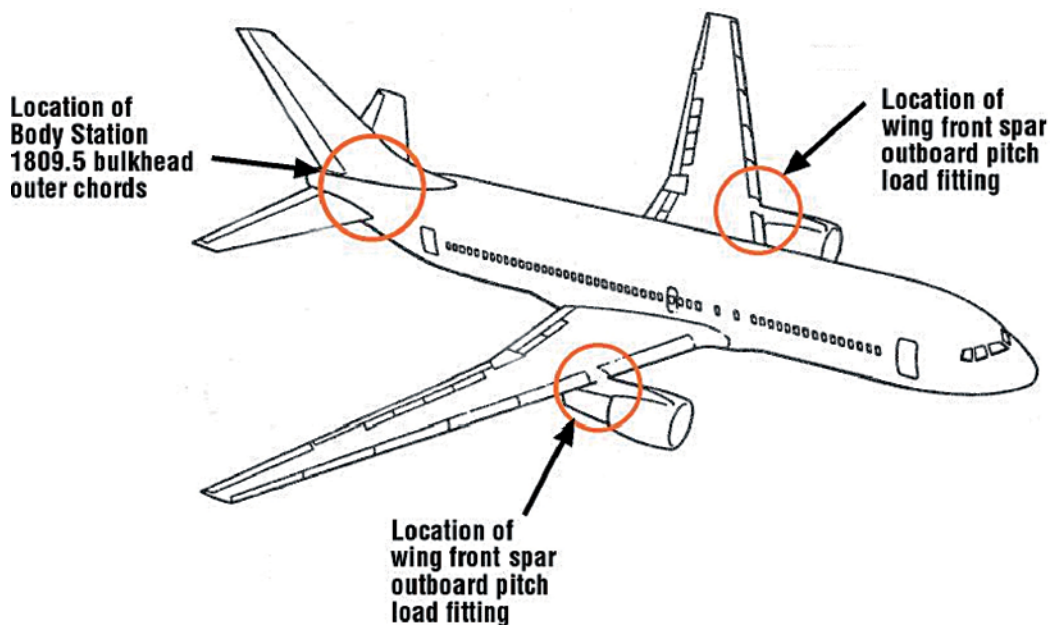
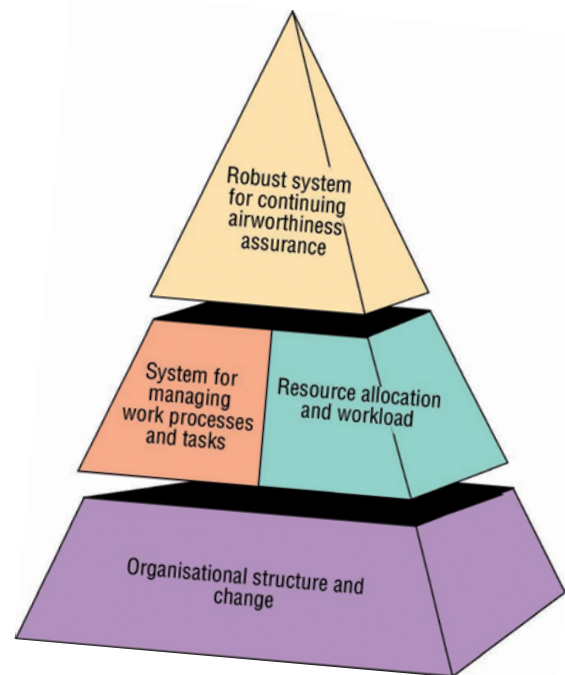

“organisational mindfulness”

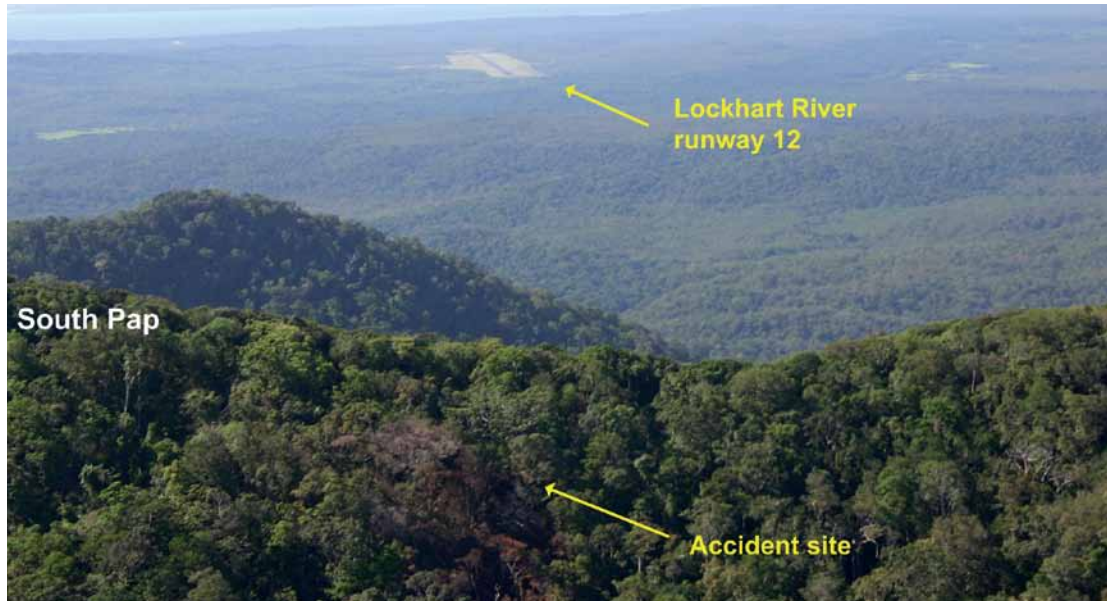

Australia's worst aviation accident for several decades

Late on the morning of 7 May 2005, a mechanically serviceable Fairchild Metro 23 aircraft, operated by Transair as Aero Tropics Flight HC675, crashed into a mountain ridge while on approach to Lockhart River Airport, Qld. The accident occurred in poor weather during a satellite-based instrument approach, probably because the crew lost situational awareness in low cloud.

The aircraft was destroyed by the impact forces and an intense, fuel-fed, post-impact fire. None of the 15 people on board survived. It was Australia's worst civil aviation accident since 1968.

An ATSB team of up to 12 investigators devoted nearly two years of painstaking work to investigating the accident. The task was complicated by the lack of an operative cockpit voice recorder or witnesses, and the extent of the destruction of the aircraft.

“numerous safety factors contributed to the accident”

The ATSB investigation into the crash of Flight HC675 revealed numerous safety factors that contributed to the accident.

The experienced 40-year old pilot in command was very likely flying the aircraft, but was reliant on the 21-year old copilot to assist with the high cockpit workload. He knew the copilot was not trained for this type of complex instrument approach. Despite the weather and copilot's inexperience, the pilot in command flew an unstabilised approach at a speed and descent rate higher than that specified in the company's operations manual. The pilot in command had a history of such flying.

The investigation found significant limitations with many aspects of Transair's operations, including pilot training and checking, the supervision of flight operations, and the management of safety.



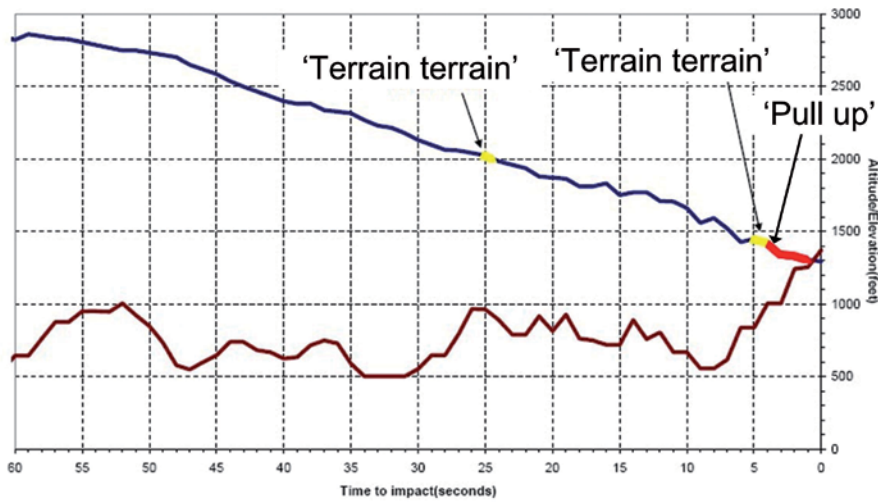

Subsequent safety action by the regulator was aimed at providing additional surveillance of higher risk passenger carrying operations. In addition, a team of safety system specialists was recruited, with a remit to focus on assessing regional airline safety management capability.

Recurring themes

Over the decades, technical advances and an increasing awareness of the importance of human factors have led to significant improvements in air safety. Nevertheless, there are some areas that continue to be of particular concern, such as fuel mismanagement, VFR into IMC accidents, and the mishandling of asymmetric flight.

Fuel mismanagement can result in either fuel exhaustion (a lack of useable fuel on board the aircraft) or fuel starvation (an interruption of the fuel supply, although adequate fuel is on board). Australian accidents involving fuel exhaustion and fuel starvation have twice been the subject of specific aviation safety research reports, one in 1987 by BASI and the other in 2003 by the ATSB, indicating that fuel mismanagement continues to be a significant safety issue.



“a safe pilot is a proactive pilot”

‘VFR into IMC’ refers to Visual Flight Rules flight into Instrument Meteorological Conditions. In simple terms, this typically involves a non-instrument rated pilot ending up in cloud, and potentially losing control of the aircraft. One of the defining features of VFR into IMC accidents is that they are usually deadly – three quarters of Australian VFR into IMC accidents involve a fatality.

As outlined in the ATSB research report *General aviation pilot behaviours in the face of adverse weather* published in 2005, pilots that successfully avoided adverse weather were characterised as having a proactive approach, best summarised by the maxim



Exhaustion and starvation accidents by contributing factors (1991–2000)

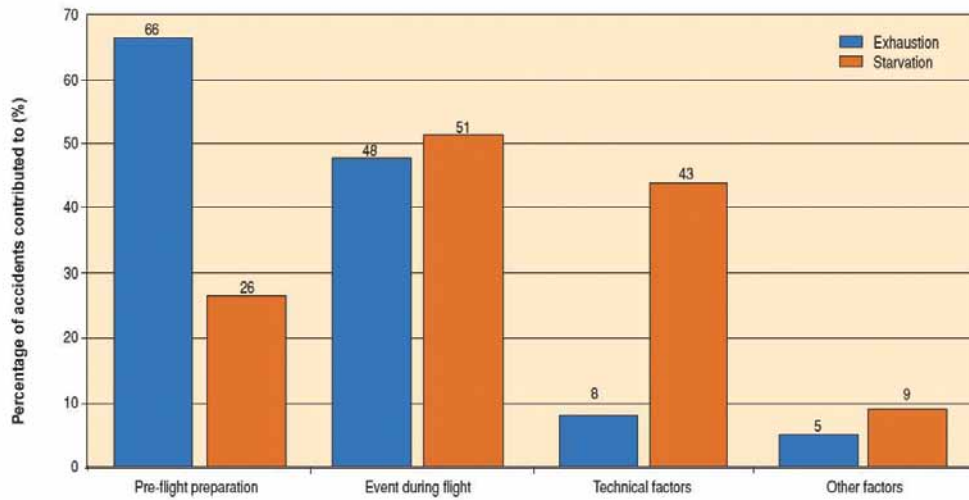

‘Take control of the situation before the situation takes control of you’. While a pilot might make a series of good decisions, that is no automatic protection against a subsequent poor decision putting the safety of the flight at risk. The flight is only ever as safe as the pilot’s last decision.

A power loss involving one engine of a twin-engine aircraft during takeoff can be one of the most challenging situations that a pilot can face. This is borne out by the fact that, contrary to expectation, a power loss accident in a twin-engine aircraft during

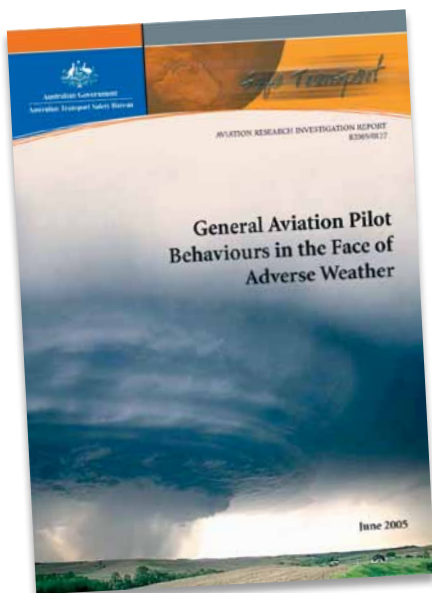

takeoff is more likely to be fatal than a power loss accident in a single-engine aircraft. In 2005, the ATSB published a research report *Power loss related accidents involving twin-engine aircraft*, highlighting the dangers of loss of control associated with asymmetric flight in twin-engine aircraft.





Dr Rob Lee

The pioneering work of Dr Rob Lee in aviation safety in general, and the application of human factors in particular, has left a lasting legacy in Australian transport safety.

Dr Lee joined the Bureau of Air Safety Investigation (BASI) in 1983 as the Bureau's first human factors specialist. He established and developed the Bureau's capability in human factors, systems safety and research.

Dr Lee became Director of BASI in 1989. During his directorship he transformed the Bureau from a largely reactive investigative agency to an innovative multi-skilled organisation that also concentrated on proactive accident prevention and safety enhancement.

As Director of BASI, Dr Lee negotiated Memoranda of Understanding to increase practical cooperation in air safety investigation in the Asia Pacific region with Indonesia, Singapore and Taiwan.

Dr Lee was instrumental in establishing and developing mutual cooperation in air safety investigation between BASI and the Australian Defence Force, including negotiating and signing the first Memorandum of Understanding between the two agencies.

Dr Lee's involvement in international air safety bodies, such as the Safety Committee of the International Air Transport Association, was instrumental in developing the reputation of the Bureau of Air Safety Investigation as a world leader in its field.



As Dr Lee outlines,

They were pioneering days, we had a fantastic team.

We changed the way we looked at investigations. The old style of investigating every single accident went out the window. In the past, if somebody had a ground loop and the undercarriage came off, we would send an out investigator at great expense to find that it was just another of those kind of accidents. It wasn't adding anything from the point of view of safety.

We decided to adopt a policy of selective investigation. To focus on those areas that would give us the most return for safety, and to focus on the fare paying passenger.

The Monarch investigation really was a watershed. It was the first fatal investigation where we used a systemic approach to accident investigation. We wanted to go right back into the organisational factors which played a part in the accident.

The old days of waiting for something to go wrong and then investigate it are definitely not the way to go. The whole shift has been to move from routine investigation to proactive system safety. So often, the main contributing factors are present and known about, and could have been fixed before the accident.

That's the way safety investigation has to go – trying to prevent things happening in the first place.

In 1999 Dr Lee was appointed Director of Human Factors, Systems Safety and Communications of the new multi-modal ATSB.

Dr Lee is a Fellow of the Royal Aeronautical Society, and a Fellow of the Chartered Institute of Logistics and Transport. In 1989 he won the Henry Wigram Award of the New Zealand Division of the Royal Aeronautical Society, and in 2000 he was awarded the Aviation Human Factors Achievement Award by the Australian Aviation Psychology Association. In 2003, he was awarded the Captain H.G. Vette Flight Safety Research Trust Fund Prize from New Zealand for his contribution to civil and military aviation safety.



Dr Lee is co-author with Professor James Reason, Captain Dan Maurino and Captain Neil Johnston, of the book *Beyond Aviation Human Factors*, first published in 1995.

In 2000 Dr Lee set up his own company, and is now an international consultant in human factors and systems safety in aviation and in other high technology industries. He is a member of the Advisory Board of the NSW Independent Transport Safety and Reliability Regulator, and the Nuclear Safety Committee of the Australian Radiation Protection and Nuclear Safety Agency.





TARAGO

HANKEN

MARINE SAFETY INVESTIGATION

The early days

Prior to the ATSB’s formation in 1999, marine safety investigations in Australia were conducted in a number of ways, under different banners.

A system of marine accident investigation, operating under United Kingdom law, had been in place since the 1850s. This system involved a preliminary investigation followed, in significant cases, by a Court of Marine Inquiry before a judge of the Federal or a State Court. This approach was adopted into Australian law in 1921 by an amendment to the *Navigation Act 1912*. The first inquiry was held in 1923 and between then and 1986, 162 Courts of Marine Inquiry were convened.

Recommendations from Courts of Marine Inquiry brought significant improvements to Australian maritime safety. In July 1974 the Court of Marine Inquiry into the sinking of the general cargo ship *Blythe Star* off the west coast of Tasmania resulted in the establishment of the Australian Ship Reporting System (AUSREP), a world’s best practice ship reporting scheme. In March 1985, the Court of Marine Inquiry into the grounding of the bulk carrier *TNT Alltrans* led to recommendations regarding the carriage and consumption of alcohol on board Australian ships. Since the recommendations were enacted, alcohol has not been a factor in any incident involving an Australian ship.

However, early marine safety investigations were not independent. They were conducted by departmental marine surveyors, effectively making the regulator both judge and jury. In addition, the process was not transparent and the surveyor’s report was not generally released. In the early days, there was a ‘presumption of negligence’ on the part of the ship’s master or crew, which created an adversarial climate in which it was often difficult, if not impossible, to elicit critical information.

In 1983, the then Commonwealth Minister for Transport, The Hon Peter Morris MHR, directed that all preliminary investigation reports should be released to the public to serve as an educational tool.

From 1983 to 1990 was a period of change. Investigations had become more specialised and several high profile accidents resulted in the existing system being questioned.

In 1990, the need for separate safety and regulatory responses to incidents with different rules and expected outcomes was identified. As a direct result, on 1 January 1991, the Marine Incident Investigation Unit (MIIU) was created under the direction of the

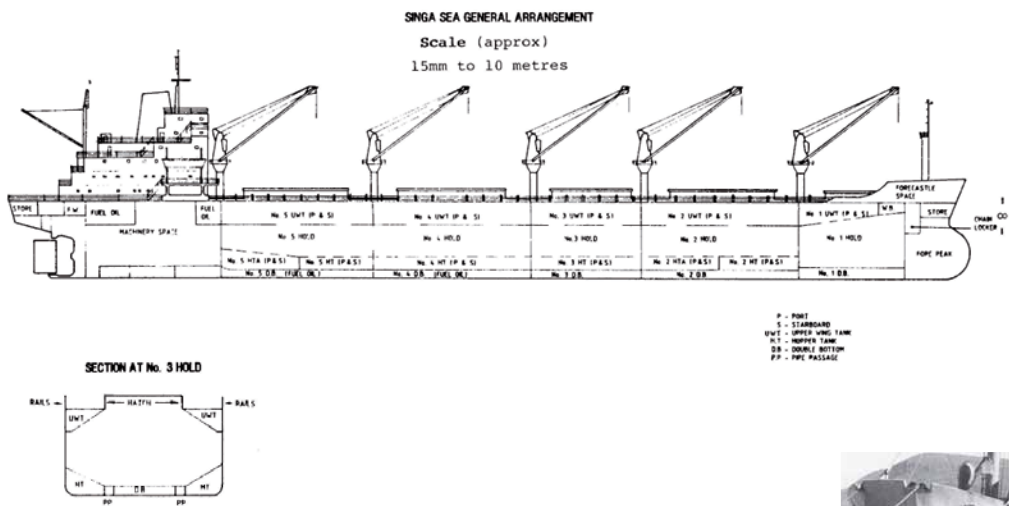



statutory position of the Inspector of Marine Accidents. Importantly, the MIU was independent of the marine regulator, the Australian Maritime Safety Authority. On 1 July 1999, the MIU became part of the new multi-modal Australian Transport Safety Bureau.

Ships of shame

During the period between 1987 and 1991, several large bulk carriers (including the *Singa Sea*, the *Cumberland*, the *Hae Dang Whu*, the *Hope Star*, the *Starfish*, the *Mineral Diamond*, the *Manila Transporter* and the *Melete*) sank during voyages from Australian loading ports. Tragically, the lives of many of the crews aboard these ships were lost.

“structural failure”

The MIU, along with other marine investigation bodies around the world, was involved in the identification of problems associated with structural integrity in older bulk carriers.

This run of bulk carrier losses was punctuated in 1991 by the high profile *Kirki* incident.

“enhanced bulk carrier safety awareness”

In July 1991, the Greek registered oil tanker *Kirki* sustained severe structural failure while it was off the Western Australian coast and its ‘bow fell off’ during rough conditions. In all, some 17,700 tonnes of light crude oil was lost due to the original bow failure and two subsequent structural failures that occurred while the ship was being towed stern first to sheltered waters off the port of Dampier, WA.

The investigations into the losses of the bulk carriers, and of *Kirki*’s bow, led to the issue of ship safety being referred to the House of Representatives Standing Committee on Transport, Communications and Infrastructure under the Chairmanship of the Hon Peter Morris.



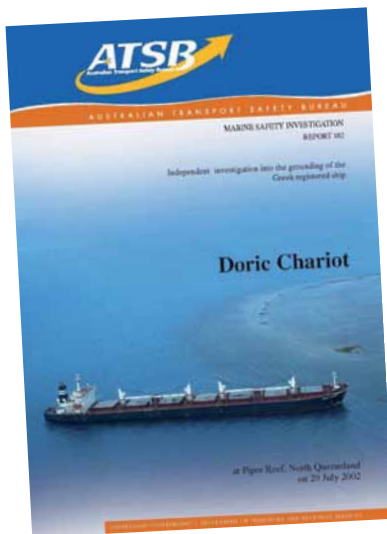

The resultant *Inquiry into Ship Safety – Ships of Shame*, had a major international impact on bulk carrier safety. The report's emphasis on the conditions under which the crews of some bulk carriers worked – and too often died – was the first to get away from the technical domain and into the human domain. It was the catalyst for raising international awareness of conditions

on board some ships and led to television documentaries and greater media scrutiny of the shipping industry.

In Australia, the incidents and subsequent inquiry report led to enhanced Port State Control inspections, an improved vetting system by Australian ship charterers, a comprehensive database of ships coming to Australia, and enhanced ship survey regimes.

The vulnerability of bulk carriers to structural failure was well illustrated on board the Malaysian registered bulk carrier *Giga 2* in Port Kembla in November 1996.

While loading water ballast into an 'in-port ballast hold', one of *Giga 2*'s bulkheads collapsed. The investigation, which also involved the Malaysian maritime authorities, questioned the quality of the class survey and the associated periodic testing technique of steel thickness. A 'finite element' analysis of the failed bulkhead conducted by the MIIU showed potential weakness in the actual design of the bulkhead and its corrugations.

The investigation also showed the danger of progressive bulkhead failure at sea should uncontrolled quantities of water enter a cargo hold. The result of the MIIU's investigation further contributed to the enhanced bulk carrier safety awareness throughout the international bulk shipping industry.

Rest, revive and survive

Like the groundings in the Great Barrier Reef of the bulk carrier *Peacock* (July 1996) and the general cargo ship *New Reach* (May 1999), the grounding of the bulk carrier *Doric Chariot* on Piper Reef, about 320 miles north of Cairns in July 2002 was attributed in a large part to poor communication between the pilot and the officer of the watch or bridge team and poor fatigue management on the part of the pilot.

“fatigue”

The MIIU and ATSB reports into these and other similar groundings in the Great Barrier Reef, contributed to a review of pilot fatigue and the introduction of fatigue management regimes for Great Barrier Reef pilots, which would be overseen by the Australian Maritime Safety Authority.

Since the formation of the ATSB in 1999, there has been only one instance of a grounding of a ship under pilotage in the Inner Route of the Great Barrier Reef, although there have been investigations into the grounding of ships manoeuvring in the channels at Cairns, Townsville and Gladstone.

A primary achievement of the MIIU, which has continued with the ATSB, has been to increase the awareness of the issue of fatigue in the international arena. After early reports suggested that fatigue and working hours were factors in some casualties, there was a challenge to 'prove' or measure the effect of fatigue. The MIIU adopted work undertaken by the Sleep Research Centre at the University of South Australia which allowed hours of work to be indexed in comparison with the effects of alcohol. This, together with work done by other agencies (including the United States Coast Guard and Cardiff University), has allowed investigators to demonstrate the likelihood of fatigue being present in accidents.

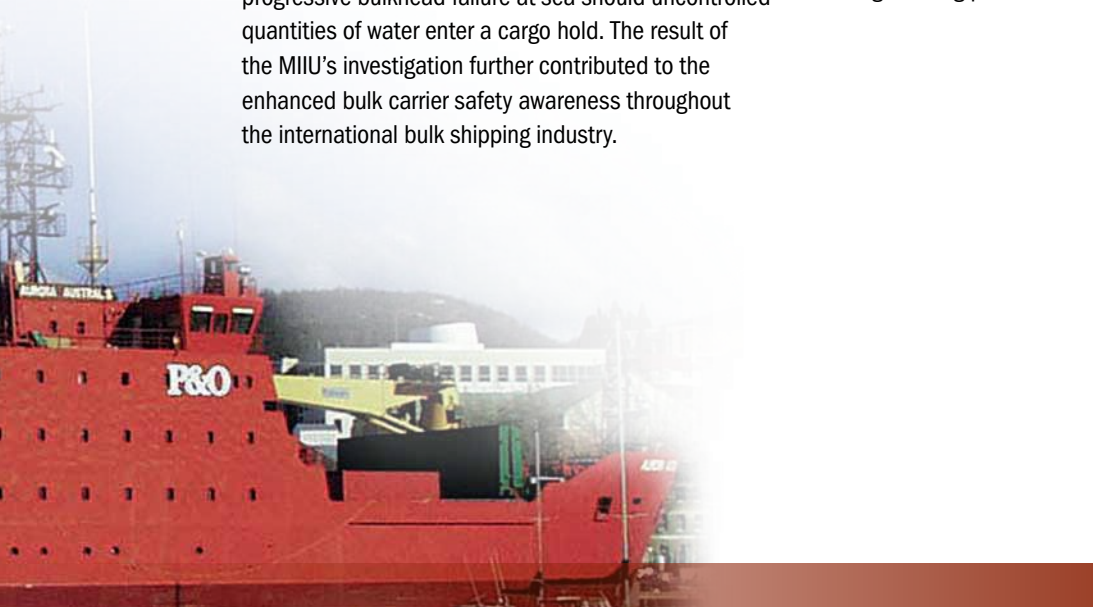



There is no ‘I’ in team

The ATSB continues to support the concept of Bridge Resource Management and advanced marine pilot training. Groundings and contact damage in port, while a pilot has the conduct of a ship, have been areas where the Australian Marine Pilots Association, supported by the ATSB, has focused on training and risk assessment techniques.

Poor Bridge Resource Management and passage planning were also significant factors in the grounding of the Australian bulk carrier *Iron Baron* at the mouth of the Tamar River, Tas, in July 1995. The ship was severely damaged and, before being refloated after six days aground, about 450 tonnes of fuel oil was lost into the sea. The ship was eventually scuttled in 4,000 metre of water, about 60 miles east-northeast of Tasmania.

“Bridge Resource Management”

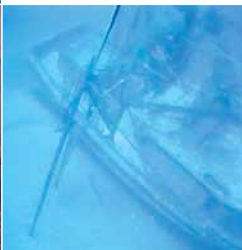

The investigation conclusions noted that the master had received no training in the safe handling of ships before being given command. The report’s findings added weight to the drive for better passage planning and management of the ship’s resources when navigating in confined waters.

Poor implementation of Bridge Resource Management principles continue to be a factor in many marine accidents and incidents investigated by the ATSB. For example, the grounding of the bulk carrier *Crimson Mars* in the Tamar River, Tas, on 1 May 2006 and the grounding of the bulk carrier *Endeavour River* in Gladstone, Qld, on 2 December 2007 both involved ineffective bridge resource management.

Lessons at the top end

A distressing multiple fatality tragedy occurred in 2005 when the *Malu Sara* became lost in reduced visibility on the afternoon of 14 October while returning to its home base on Badu Island, in the Torres Strait, and sank during the early hours of 15 October. Unfortunately, none of the five occupants of the boat, including a four year old child, survived and only one body was subsequently recovered.

“deficient design and construction”



The *Malu Sara* was one of a fleet of six small six metre vessels, powered by twin outboards, operating as part of a 'people movement' monitoring program in the Torres Strait. The vessels were classed as 'Commonwealth Ships' under the provisions of the *Navigation Act (1912)*.

The investigation identified issues of deficient design and construction of the boats, and a lack of risk management in the operation of the boats.



Subsequent safety action by regulators has resulted in the implementation of the Torres Strait Maritime Safety Strategy. This strategy aims to take a long term approach to maritime safety issues in the region and has targeted community involvement, education, regulation and the strengthening of the maritime safety culture. Requirements for smaller Commonwealth vessels, their crew's qualifications and the type of safety equipment carried on board, have also been reviewed and strengthened.

Additional action has been taken to clarify search and rescue coordination arrangements. A revised sighting assessment procedure has been developed to expand

upon the existing international guidance about the evaluation and analysis of information gathered during a search operation.

Watching me, watching you

An ongoing concern for the ATSB is the issue of ship and fishing vessel accidents which occur off the Australian coast. Since 1982, there have been 58 collisions or near misses involving ships and small vessels that have been investigated by the ATSB or the MIU.

In 2005, the ATSB initiated a safety awareness campaign for the fishing industry in an attempt to promote the issues uncovered during these investigations. The campaign was accompanied by the publishing of a number of safety bulletins and a DVD, which was jointly produced and distributed by the ATSB, the Australian Maritime Safety Authority and Maritime Safety Queensland.

The ATSB continues to be active in the Australian maritime sector. Apart from the wide distribution of safety investigation reports and safety bulletins, the Bureau's marine investigators are actively involved in training courses associated with Bridge Resource Management and marine pilot training. The ATSB also presents at relevant maritime conferences and forums around Australia and has regular constructive interaction with similar investigative agencies, both nationally and internationally.







Captain Kit Filor, PSM

Captain Kit Filor, PSM, was appointed as the first Inspector of Marine Accidents in August 1990, and led the newly formed Marine Incident Investigation Unit (MIIU) from its inception in January 1991.

Until then, the investigation of marine accidents often concentrated solely on breaches of the regulations, and typically started with a 'presumption of negligence' on the part of the ship's crew.

Captain Filor was instrumental in bringing about a sea change in the way in which marine investigations were conducted, both within Australia and internationally. He was instrumental in formulating the International Maritime Organization Code for the Investigation of Marine Casualties and Incidents.

The new approach to marine accident investigation did not focus solely on the actions of individual seafarers, but equally considered the broader context in which the accident occurred.

Under Captain Filor's leadership, the MIIU operated on the basis of 'no blame' investigations. Investigation reports were designed to be read by the people most affected by casualties and accidents – the seafarer. The Unit developed a wide readership around the world including maritime training establishments.

As Captain Filor outlines,

The Unit also developed and championed an international uniform approach to accident investigation through the International Maritime Organization, focused on understanding the organisational issues and contributory factors in any complex investigation. This led to a demand for training, particularly from developing countries around the world.

It was challenging and hugely rewarding time for all those in the Unit.

With the inception of the ATSB in July 1999, Captain Filor was appointed Deputy Director Surface Safety, with responsibility for both marine and rail safety investigation. In this role he was instrumental in bringing the same safety principles that he had fostered in marine investigation into the rail sphere.

Captain Filor is a Fellow of the Nautical Institute – a recognition of his significant contribution to the advancement of marine accident investigation in Australia. From 2001 to 2004 he served as Chairman of the Marine Accident Investigators International Forum.

In 1996, Captain Filor was awarded the Public Service Medal for services to marine safety.

Captain Filor retired from the ATSB in August 2006. He remains active in lecturing in accident investigation for the International Maritime Organization and for overseas administrations. He also runs marine safety programs and exercises.

The approach pioneered by Captain Filor over 20 years ago continues in the surface safety branch of the ATSB today.

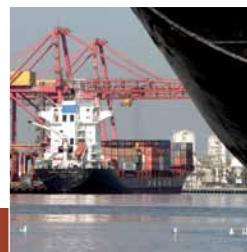



RAIL SAFETY INVESTIGATION

The early days

In a country where passengers had to change trains at State borders as late as the 1970s, it is perhaps not surprising that the start of a coordinated national approach to rail safety investigation was a long time coming.

Traditionally, rail safety in Australia has been a State responsibility. However, with the inception of the ATSB in July 1999, followed by the enactment of the *Transport Safety Investigation Act* in 2003, Australia had for the first time a national body with a mandate for rail safety investigations.

In its relatively short existence, the ATSB's rail safety investigation team has had a significant influence on the way that rail safety is thought about in Australia. In particular, it has been instrumental in fostering an approach that emphasises the importance of system safety, rather than just focussing on the mistakes of operational personnel.

Other notable achievements of the ATSB in rail investigations have included raising awareness within the rail industry of the importance of modern health and safety standards for operational personnel,

seeking improvement in communications and signalling, modelling track/rolling stock dynamics and highlighting specific accident types such as level crossing collisions between trains and heavy road vehicles.

Coming together

Eleven rail safety investigations were conducted under the relevant State legislation before commencement of the *Transport Safety Investigation Act* on 1 July 2003. Since that date, the ATSB's jurisdiction for rail occurrences has been the Defined Interstate Rail Network (DIRN), the national standard gauge system that links all of Australia's major mainland cities and ports.

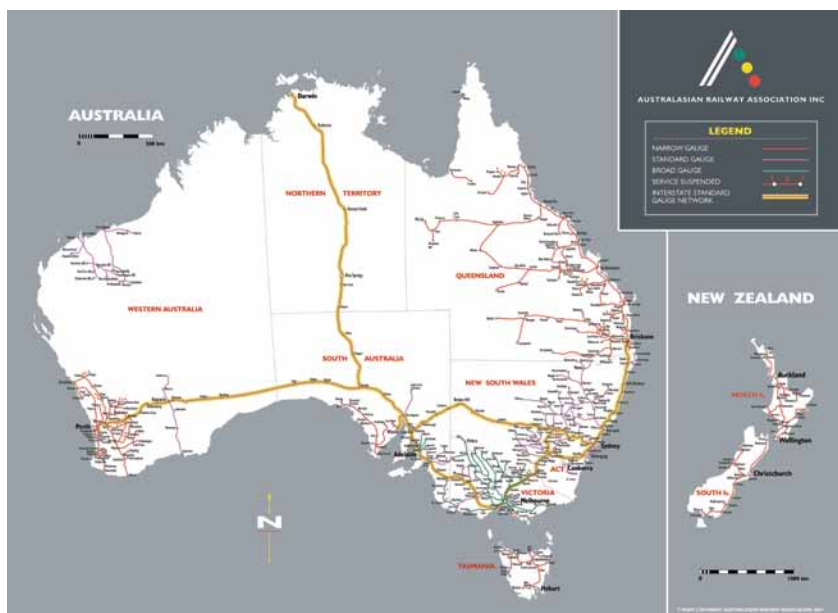

Australasian Railway Association Inc.



There was extensive consultation with the rail industry and State and Territory rail safety regulators prior to commencement of the *Transport Safety Investigation Act*. Its advent was significant for the rail industry for a number of reasons. It marked the start of national, independent rail safety investigations that took a systemic and 'no blame' approach. It also mandated the public release of all reports.

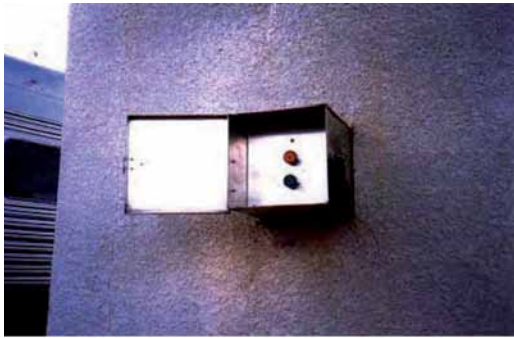

To err is human

Soon after the ATSB was formed, it assisted an investigation into a collision between two trains at Zanthus in Western Australia where the investigation found that systemic factors as well as human error contributed to the accident.

On 18 August 1999, just after 5 pm, the Indian Pacific passenger train travelling from Adelaide to Perth was inadvertently directed onto a loop line at Zanthus, where it collided with a stationary freight train. Seventeen passengers and four train crew required medical treatment, and significant damage was caused to the locomotives and carriages.

As the Indian Pacific approached, the driver of the freight train was waiting at a control box to switch the points once the Indian Pacific had passed. This would allow the freight train to return to the main line and continue its journey. However, the driver inadvertently pressed the control button before the Indian Pacific had passed, directing it onto the loop line where it collided with the stationary freight train. Although the driver realised his mistake, the design of the system was such that he was not able to immediately reverse the movement of the points and avert the collision. Subsequently, Australian Rail Track Corporation upgraded the system to prevent a similar occurrence in the future.

Three months later, on 26 November 1999, a similar accident occurred at Ararat in Victoria. A rail employee wrongly moved the points and diverted a grain train into the Ararat yard, where it collided with a stationary ballast train. Two train crew members were seriously injured. Again, given it was possible to move the points in front of an oncoming train, the ATSB led investigation determined that the system in operation at Ararat was fragile in the face of human error.

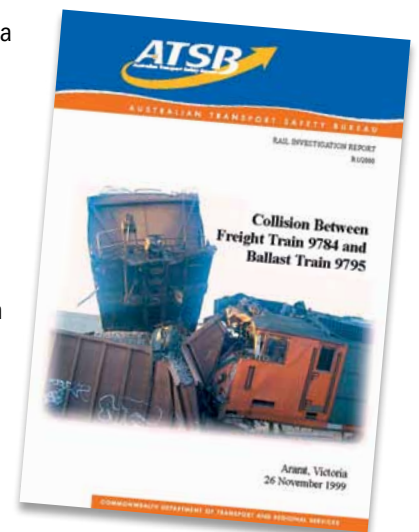



Fit for purpose

A number of ATSB rail safety investigations found significant differences in health standards between State and Territory jurisdictions, and compared with health standards for safety critical workers in other modes of transport. Recommendations issued in ATSB rail safety investigation reports were a catalyst in formulating the *National Standard for Health Assessment of Rail Safety Workers*.

For example, on 5 June 2001, an empty suburban electric express train collided with the back of a suburban passenger train at Footscray station in Victoria. The passenger train had about 20 people on board. The driver of the express train was injured, and two passengers were taken to hospital for observation.

“a number of defences in the system were identified as being inadequate”

There was strong evidence that the performance of the driver of the express train was impaired by a medical condition that led to him being unable to recall the events in the minutes before the collision. The driver was taking a course of prescribed medication which, combined with an early start to work that day and a history of chronically disturbed sleep, may have resulted in him falling asleep for a short period while he was driving the train.

While there were safeguards in place to protect the safety of the system from such an eventuality, on this occasion they did not prevent the accident. A number of defences in the system were identified as being inadequate in terms of design or application. For example, one defence that was inadequate was the ‘dead-man’s pedal’, designed to automatically apply the train brakes if there was any variation in applied pressure due to driver incapacitation. The ATSB’s investigation found that in certain circumstances the pressure on the foot pedal could be correctly maintained just by the weight of the driver’s lower leg, regardless of whether or not he was incapacitated.

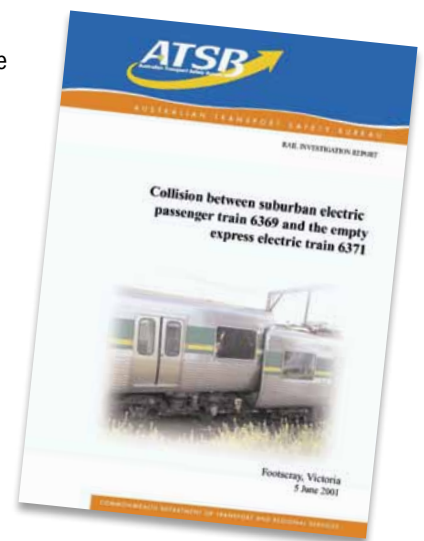



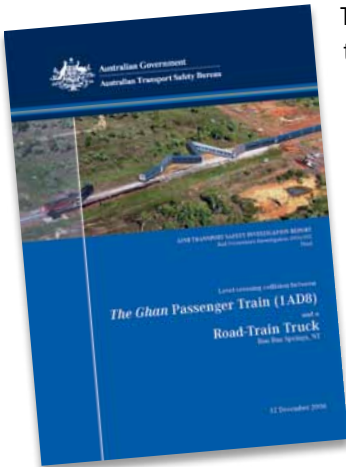

The alertness and fitness of drivers to perform their duties is also a defence against accidents. In the Footscray collision, the investigation found serious defects in the monitoring of the driver's health and fitness. It also found that the health standards used to assess driver fitness were inadequate. As a result, although the driver was skilled and experienced, he was not medically fit to operate the train.

In some cases, the ATSB is requested to assist with rail investigations that would not otherwise fall within its area of responsibility.

On 31 January 2003, at 7:14 am, a four car Tangara suburban passenger train travelling from Sydney Central railway station to Port Kembla, left the track at high speed and overturned about 1.9 kilometres south of Waterfall railway station in New South Wales. The train driver and six passengers were killed. The train guard and the remaining 41 passengers suffered injuries ranging from minor to severe.

“the train left the track at high speed and overturned”

The ATSB was asked to assist the Counsel Assisting the Special Commission of Inquiry into the Waterfall Rail Accident. In the early stages, ATSB investigators provided advice to the Commission's panel of experts about the conduct, structure and a systemic approach to the overall investigation.

Look before you leap

Level crossing accidents have been identified as the number one risk to the safety of the rail industry. Since May 2006, the ATSB has investigated 14 significant level crossing accidents. Eleven involved a collision with a heavy road vehicle, and five of those collisions were with a passenger train. The investigation of these level crossing accidents has primarily focused on road user issues which were found, in most cases, to be the most significant contributing factors.

On 25 May 2006, a Kenworth tipper truck and tipper trailer carrying a load of 30 tonnes of citrus pulp collided with a freight train near Lismore, Vic. Two locomotives and 41 of the train's 64 wagons were derailed, and the driver of the truck was fatally injured. The estimated direct cost of the collision was upwards of \$13.5 million.

At the time of the accident the area surrounding the level crossing was enveloped in very thick fog, with visibility less than 50 metres. The investigation found that the truck was not being driven in accordance with those conditions, and that the performance of the truck driver may have been affected by fatigue. In addition, the level crossing approach signage and sighting distances were not in accordance with the relevant standards.

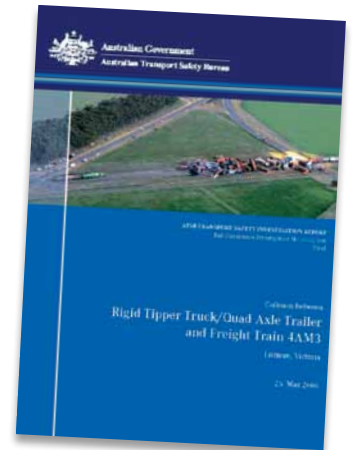

“the level crossing was enveloped in very thick fog”

New heavy vehicle driver fatigue laws commenced in late 2008 in Queensland, New South Wales, Victoria and South Australia. The reform targeted the root cause of driver fatigue, rather than simply regulating hours, and made all parties in the supply chain legally responsible for preventing driver fatigue.





On 12 December 2006, a double trailer road-train drove into the path of *The Ghan* passenger train at a level crossing near Ban Ban Springs in the Northern Territory. As a consequence, two locomotives, a wagon used for carrying passengers' vehicles and nine passenger carriages derailed. While there were no fatalities, the road-train driver and a female passenger were hospitalised and several other passengers and crew sustained minor injuries.

The investigation concluded that the truck was driven through the 'Stop' sign at the level crossing at a speed of about 50 kilometres per hour. The driver was very familiar with the crossing and had a habit of slowing rather than stopping at the crossing. He may have been influenced by the expectation that a train would not be present and by the operational constraints of road-train vehicles. In addition, he may not have heard the warning of the train's horn because he had severe hearing loss.

Large heavy road vehicles can take a long time to stop and to get going again. As part of the ATSB investigation, trials were done at the Ban Ban Springs level crossing to see how long it would take a large road train to traverse the crossing under different conditions. The results showed that, in certain circumstances, the time taken for the test vehicle to clear the level crossing from a standing start was longer than the standard time used to calculate sighting distances. The results of the ATSB's trials, detailed in the investigation report, have wider implications in relation to the adequacy of the current standards for sighting distances at level crossings.

Since the accident, a level crossing assessment group has been formed to examine all level crossings in the Northern Territory.

**“large heavy road vehicles
can take a long time to
stop and to get going again”**

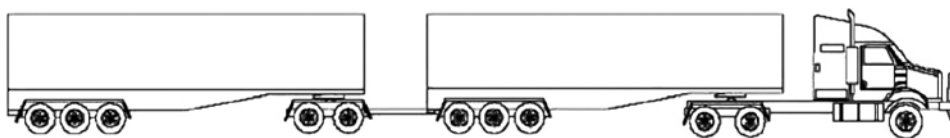



The ATSB compiled a *Railway level crossing safety bulletin* to highlight key lessons learnt during the investigations. Foremost are the operational limitations of trains, and the resultant onus on motorists to avoid collisions. Copies of the bulletin were sent to State and Territory rail regulators, and the Australasian Railway Association and the Australian Trucking Association distributed the bulletin through their membership networks.

Knowledge is power

As part of the shared responsibility for rail safety in Australia, industry reports rail safety occurrences to the regulators. The regulators and operators use this data to assist with their safety analyses and programs. The ATSB plays an important coordination role by collecting, collating and publishing national rail safety occurrence data, provided by all State and Territory regulators, on its website.

The data are designed to assist rail safety professionals and researchers in understanding and mitigating risk. In addition, the data can be used for international comparative research, while informing the public about emerging issues in rail safety.

Future directions

While the ATSB's work in rail safety investigations is still relatively new, the rail industry has enthusiastically embraced the concept of independent, systemic accident investigations. A Memorandum of Understanding has been signed with most State and

Territory rail safety regulators for the conduct of railway safety investigations to ensure a shared understanding of each other's roles and responsibilities.

Members of the ATSB's rail safety investigation team regularly participate in industry forums, make numerous presentations to the industry, conduct training, and participate and assist with various industry initiatives and workshops. For example, an ATSB rail team member regularly makes a presentation at the Australasian Railway Association's 'Understanding Rail' course. This course is designed for new members of the industry, and offers a comprehensive and high level overview of the operational, technical, legislative and business environment of Australia's railway industry.

The ATSB's rail safety investigation team will continue to closely support the industry by working with rail industry stakeholders including owners, operators and safety regulators, to identify and focus on critical safety issues. The ATSB will continue to build its reputation for excellence in rail safety investigations.

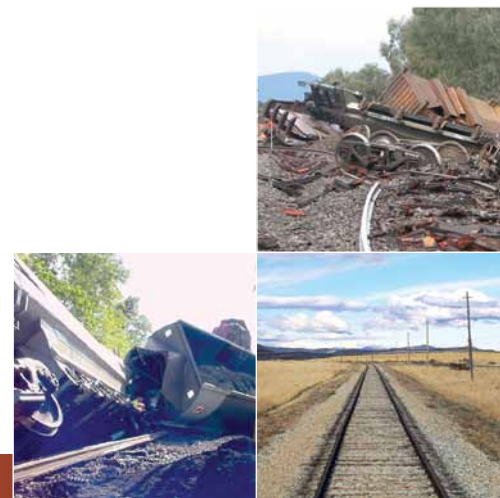



ROAD SAFETY INITIATIVES

No area of transport safety directly affects the majority of Australians more than road safety. The cost of road crashes in Australia is enormous – conservatively estimated at \$18 billion per annum – and the social impacts are devastating.

While many aspects of road safety are the domain of State and Territory governments, the Australian Government also has an important role in making our roads safer for all road users. In particular, its role has typically been in developing and coordinating national road safety programs.

From July 1999 until March 2008, Australian Government road safety initiatives were primarily the responsibility of the ATSB.

While part of the ATSB, the Road Safety branch was involved in many state and federally based programmes and research projects. The branch contributed to the development of informed road safety policies by collecting and disseminating national road crash statistics, producing research and public information materials, and providing evidence-based advice on a range of road safety issues. It also coordinated a number of national stakeholder bodies and events, including the biennial Indigenous Road Safety Forum and the National Road Safety Strategy Panel.

Protecting the young

Novice drivers aged from 17 to 25 years have a high level of crash involvement compared with older drivers, and account for about a quarter of Australian road fatalities. To address this critical road safety issue, between 2005 and 2008, the ATSB led the development of an innovative post-licence education program for Australian novice drivers.

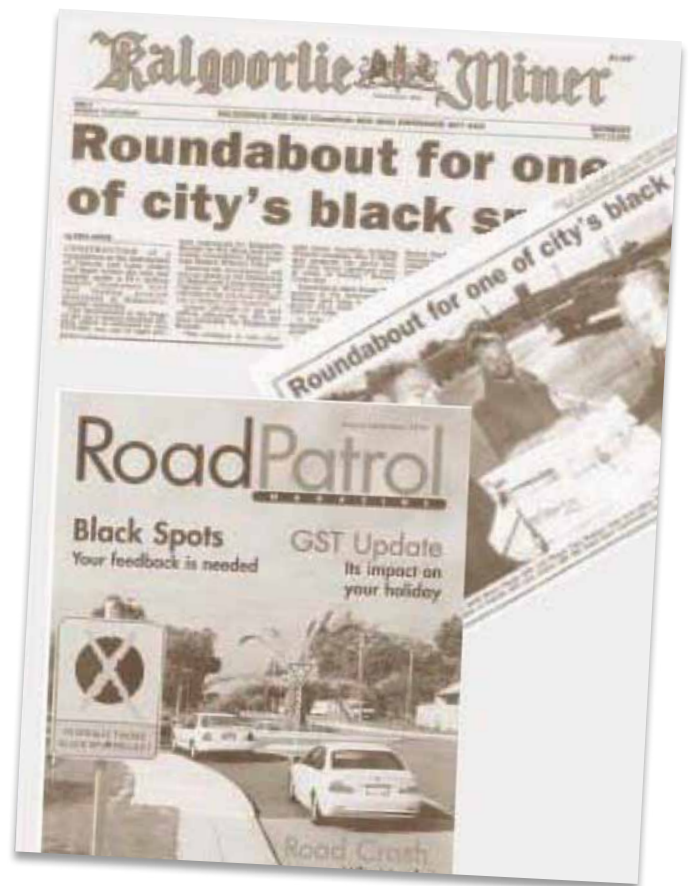

Research and education

The Road Safety branch of the ATSB made significant contributions to the development of road safety policies through research and analysis of a wide range of road safety topics, including seatbelt use, the role of human error in crashes, young driver risk factors, speeding behaviour, Indigenous road safety issues, motorcycle rider behaviour, vehicle crashworthiness and vehicle advertising content. The ATSB's annual survey of community attitudes to road safety was a valuable mechanism for monitoring attitudes to a variety of road safety issues.

The ATSB distributed a range of resources for use by road safety agencies, educational institutions, training organisations, and members of the public. Topics included first aid, child safety, drink driving, learner drivers, motorcycle safety, speed, fatigue, and vehicle safety.

“significant contributions to the development of road safety policies”

Numbers count

The ATSB Road Safety branch was responsible for collecting, analysing and disseminating national statistics on road trauma – information that is essential for creating informed road safety policies. The ATSB maintained national databases compiled from a range of sources, including State and Territory road authorities, police organisations, coronial reports, and the Australian Bureau of Statistics. Information was disseminated in regular bulletins on roads deaths, fatal heavy vehicle crashes, and comparison of Australian road fatality statistics with data from other OECD countries.

An ambitious target

The National Road Safety Strategy 2001–2010 provides a framework to complement the road safety strategies of State, Territory and local governments. The target of the strategy is to reduce the annual rate of road fatalities by 40 per cent by the end of 2010, using the population fatality rates in 1999 as a benchmark. The strategy involves developing measures to address road user behaviour, improving the safety of roads and roadsides, and accelerating the introduction of vehicles with improved safety systems. The Executive Director of the ATSB, Kym Bills, chaired the National Road Safety Strategy Panel from July 1999 to March 2008.

“The National Road Safety Strategy 2001–2010”

Getting out and about

As well as being a member of the National Road Safety Strategy Panel, the ATSB actively participated in other national roads safety forums. The ATSB chaired the Indigenous Road Safety Working Group and Forum from its inception. In 2006, the ATSB with assistance from the Office of Road Safety in Western Australia, convened the 3rd Indigenous Road Safety Forum in Broome.

The road ahead...

The Road Safety Branch is now part of the Infrastructure and Surface Transport Policy Division of the Department of Infrastructure, Transport, Regional Development and Local Government. It continues to pursue its role of improving national road safety.







THE INTERNATIONAL DIMENSION

Aviation

As a founding member of the International Civil Aviation Organization (ICAO), Australia has played a prominent role in the Council and the Air Navigation Commission (ANC). Since 1974, Australia has consistently been elected to the council as a Category One State of Chief Importance in Air Transport, and plays a major part in the activities of ICAO. Australia's role has been underpinned by its perceived integrity and lack of bias, and excellent safety record.

“a founding member of ICAO”



Australia played a significant role in the seventh ICAO Accident Investigation and Prevention (AIG) Divisional Meeting in Montreal in 1999, and again during the eighth AIG Divisional Meeting in Montreal in 2008. In 2008, Kym Bills led the Australian delegation that had a major influence in the meeting agreeing to initiatives such as allowing investigation authorities to allocate resources based on expected safety value, the introduction of the term 'contributing factors' in the ICAO report format, and the establishment of a working group to further review how sensitive safety information is shared and protected.

Within the area of aviation safety investigations, Australia has been an active member of the international system, both through multilateral institutions like ICAO, and bilaterally in our region and beyond.

The ATSB, and formerly BASI, have been active members of the International Society of Air Safety Investigators (ISASI). ISASI was founded in 1977 to promote international learning and cooperation in aviation safety by the exchange of ideas, experiences and information about aircraft accident investigations, and to otherwise aid in the advancement of flight safety. ATSB investigators also make significant contributions to the Australia and New Zealand regional chapter of the society, ANZSASI, which was founded in 1994. Australian investigators are well respected by their international colleagues, as they bring to the table significant levels of professional expertise and new approaches to aviation safety investigation procedures and techniques.

Helping our neighbours

Australia's engagement with overseas counterparts is typical of the way the international aviation community cooperates for the common good. Lessons that will benefit safety are shared openly, and the knowledge gained assists other countries with improved passenger safety and better trained safety investigators.

Australia's reputation for high quality and rigorous investigations makes it uniquely placed to assist aviation safety in the Asia Pacific. Over the last 25 years Australian investigators have assisted several of our regional neighbours during complex aviation investigations.

Australian air safety investigators assisted in the 1997 investigation of a Controlled Flight Into Terrain (CFIT) accident involving an Garuda Indonesia A300 that flew into mountainous terrain on approach to Medan, resulting in the death of all 234 passengers and crew.





They also assisted when, only months later a SilkAir Boeing 737, cruising at 35,000 feet enroute from Jakarta to Singapore, was destroyed when it impacted the Muse River at high speed. The location and complete destruction of the aircraft contributed to this being a very challenging investigation.

On 31 January 2003, an Ilyushin 76TD aircraft impacted terrain during a landing approach to Baucau, Timor-Leste. The six aircraft occupants were fatally injured by the impact forces. At the request of the government of Timor-Leste, the ATSB conducted the investigation into the accident. The investigation report highlighted that deviations from recommended practice during the approach and landing phase of flight significantly increase the risk of a CFIT event.

“invaluable support to countries in our region”

In addition to the onsite investigation support, the ATSB and its predecessor has provided invaluable support to countries in our region with specialist support, particularly for flight data and cockpit voice recorder download and analysis. Over the years the ATSB has offered its specialist equipment and technical experts to help investigations in Indonesia, Fiji, Papua New Guinea, the Philippines, Taiwan, Malaysia, China and Singapore. That help has contributed to improved aviation safety for our neighbours.

Cooperation and capacity building

On March 2007, a Garuda Indonesia Boeing 737 attempted to land at Yogyakarta airport in central Java after an unstabilised, steep and high approach. The aircraft overran the runway while still travelling at high speed and came to rest in a paddy field outside the airport boundary. The impact and the subsequent fire claimed 21 lives, with others receiving serious injuries. Five of those who lost their lives were Australians.





At the request of the Indonesian Government, the ATSB dispatched three senior aviation investigators, including an ATSB Director to Jakarta to assist counterparts in the Indonesian National Transportation Safety Committee (NTSC). Back in Canberra, flight data and cockpit voice recorder experts were standing by and received the two 'black boxes' recovered from the badly burnt wreckage.



This tragic accident was the start of a new initiative that sees Australian transport safety professionals working closely with their Indonesian counterparts in an effort to enhance safety and build additional capacity to meet the challenges facing Indonesia. In May 2007, the Australian Government announced the Indonesia Transport Safety Assistance Package (ITSAP), amounting to nearly \$24 million over three years.

The ATSB appointed Alan Stray, PSM, Director International, to oversee and coordinate the ATSB's involvement in this important regional transport safety initiative.

The main elements of the ATSB's contribution to ITSAP are to deliver training and support for NTSC investigators. This includes the ATSB providing staff dedicated to various capacity building projects, funding ATSB training courses in Indonesia and Australia, and expand opportunities for aviation, marine, and rail investigators to work with ATSB counterparts for extended periods. Support is also being provided on individual transport safety investigations.

Cooperation on transport safety is adding another dimension to the Australia-Indonesia relationship, and works towards our shared aim of safer transport systems. This program highlights the importance of international engagement in the field of transport safety investigation.

In January 2009, Alan Stray was awarded the Public Service Medal "For outstanding public service improving aviation safety in Australia and Indonesia".

"shared aim"







Marine

The MIIU was involved in a number of important international initiatives to promote and foster marine incident investigation. In 1992, the Marine Accident Investigators International Forum (MAIIF) was formed. For a period of four years, this Forum was chaired by the ATSB's Deputy Director, Surface Safety. MAIIF continues to meet annually and promote international cooperation in marine investigation.

Closely aligned with MAIIF's early work was a submission to the International Maritime Organization (IMO) for the *Code for the Investigation of Marine Casualties and Incidents*, jointly proposed by Australia, Hong Kong and Vanuatu. The MIIU drafted and prepared the papers, discussion documents and the draft Code. The MIIU was instrumental in the Code being adopted in 1997 by the IMO Assembly.

In 2005, the ATSB marine investigation unit played a strong part in initiating a review of the Code, to incorporate improvements in line with developments in marine safety investigation. The amended Code is to be annexed to the *International Convention for the Safety of Life at Sea (SOLAS)*.

The MIIU was also instrumental in radically redrafting the IMO model training course for marine accident and incident investigations, and assisted in the drafting and adoption of the *International Safety Management Code* that was introduced in stages from 1998. The purpose of the Code is to provide an international standard for the safe management and operation of ships and to protect the marine environment.

International Transport Safety Association

On 1 January 2001, the ATSB became a member of the International Transportation Safety Association (ITSA). ITSA members must be independent of their national regulatory bodies and comprise recognised safety professionals. The mission of ITSA is "to improve transport safety in each member country by learning from the experiences of others".



The ATSB's Executive Director, Kym Bills, became the Chairman of ITSA on 1 March 2006 and hosted ITSA's annual meeting in Canberra later that month. ITSA currently has 14 members. In addition to the ATSB, they are from the US, Canada, the Netherlands, Sweden, Finland, Norway, the United Kingdom, New Zealand, India, Japan, Chinese Taipei, South Korea, plus the Moscow-based Interstate Aviation Commission.





OVER THE HORIZON

There are exciting and challenging times ahead for the ATSB.

The winds of change

In 2007, Mr Russell Miller, AM, was tasked by the Federal Government to review the relationship between the Civil Aviation Safety Authority and the ATSB. Mr Miller recommended the Australian Government move to clarify the ATSB's independence as the national safety investigation agency.

The Australian Government accepted this key recommendation, which received strong support from industry, and addressed it in the National Aviation Policy Green Paper which was released on 2 December 2008 by our Minister, the Hon Anthony Albanese.

“Flight Path to the Future”



On 1 July 2009, the ATSB became a statutory agency outside the portfolio department with its own budget and staffing, led by a full time Chief Commissioner/ CEO and two part-time Commissioners. Such governance arrangements are in accordance with international best practice, and fulfil a long held ATSB vision. Not only will the ATSB continue to have

operational independence with respect to the exercise of its investigation powers, but it will have newly established functional independence with respect to the administration of its resources.

Independent investigations are crucial for transport safety. Independence ensures there is no perceived, or actual, conflict of interest or external interference from the parties involved in an accident, or from transport regulators or government policy makers.

Many unknowns

The Commonwealth Government has an ambitious regulatory reform agenda in the marine and rail industries aimed at improving the efficiency, safety, sustainability and competitiveness of those industries.

The ATSB is considering the implications of such reforms, and developing plans to ensure it responds accordingly.



Increased competition and the effects of the global financial crisis have the potential to put pressure on industry safety standards. The transport industry and Australia's safety agencies will need to be poised to identify and respond quickly to any lessening of acceptable standards.

Australia has a proud safety record, and ongoing vigilance by our safety agencies is critical to ensuring that this is maintained and enhanced.





AVIATION SAFETY DIGEST

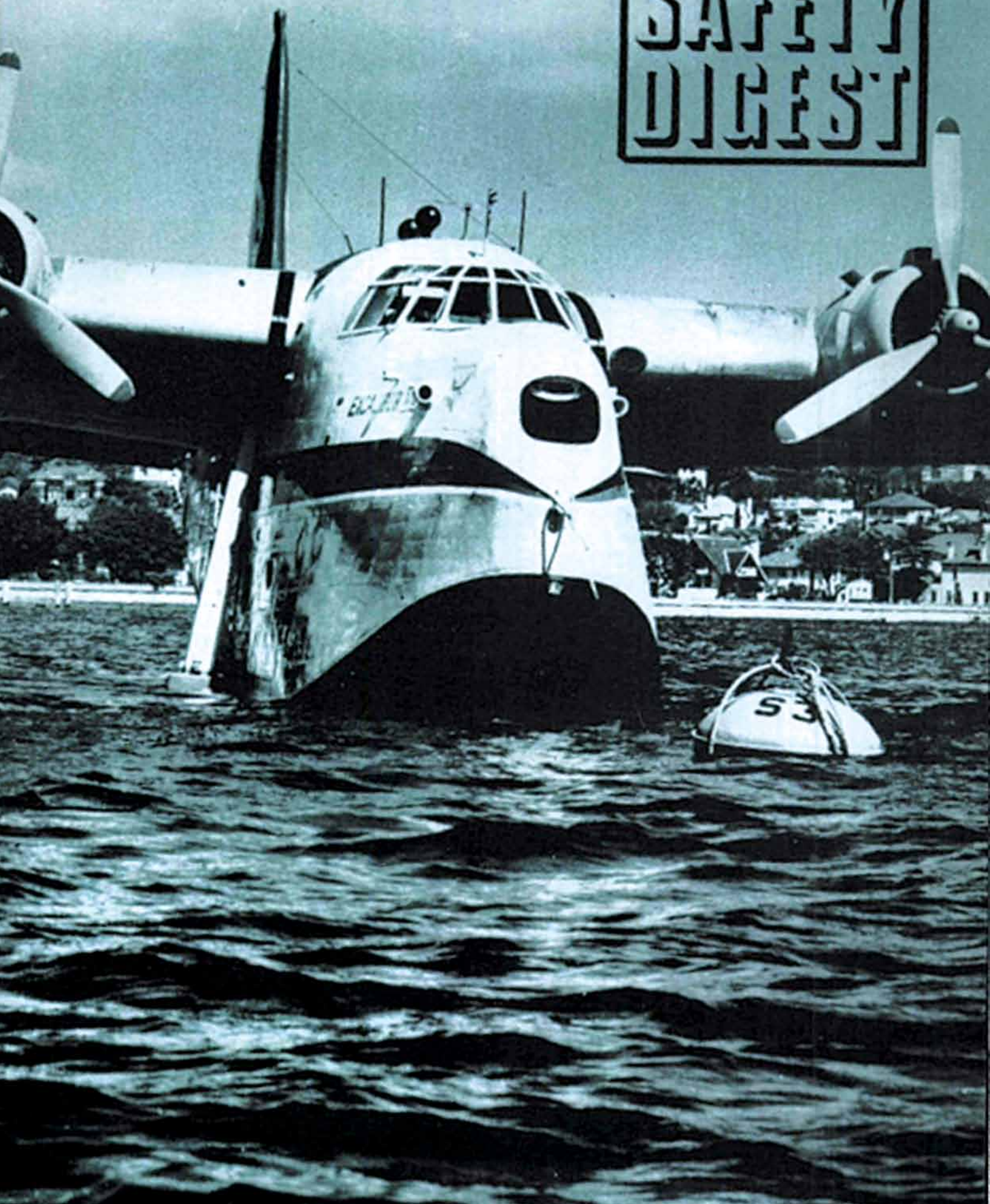

PAST PRESENT FUTURE WEBSITE

Want to know more?

If you would like further information about the ATSB, just go to the Bureau website at www.atsb.gov.au

All of the reports referred to in this book are available from the *Past Present Future* section of the ATSB website – just click on the *Past Present Future* link in the *Shortcuts* panel on the right-hand side of the ATSB home page.

The *Past Present Future* section of the ATSB website also includes a range of related historical material published by the Australian Transport Safety Bureau and its predecessor organisations.

Come back from time to time – additional historical material will be included in the *Past Present Future* section of the ATSB website as resources permit.

