



Australian Government  
Australian Transport Safety Bureau

# Collision of passenger train A42 with buffer stop

Richmond, New South Wales | 22 January 2018



Investigation

**ATSB Transport Safety Report**  
Rail Occurrence Investigation  
RO-2018-004  
Final – 20 December 2019

**Cover photo:** Front of A42 at Richmond Station after collision with buffer stop. Source ATSB.

This investigation was conducted under the *Transport Safety Investigation Act 2003* (Cth) by the **Office of Transport Safety Investigations (NSW)** on behalf of the Australian Transport Safety Bureau in accordance with the Collaboration Agreement entered into on 18 January 2013.

Released in accordance with section 25 of the *Transport Safety Investigation Act 2003*

#### **Publishing information**

**Published by:** Australian Transport Safety Bureau  
**Postal address:** PO Box 967, Civic Square ACT 2608  
**Office:** 62 Northbourne Avenue Canberra, Australian Capital Territory 2601  
**Telephone:** 1800 020 616, from overseas +61 2 6257 4150 (24 hours)  
Accident and incident notification: 1800 011 034 (24 hours)  
**Facsimile:** 02 6247 3117, from overseas +61 2 6247 3117  
**Email:** [atsbinfo@atsb.gov.au](mailto:atsbinfo@atsb.gov.au)  
**Internet:** [www.atsb.gov.au](http://www.atsb.gov.au)

© Commonwealth of Australia 2019



#### **Ownership of intellectual property rights in this publication**

Unless otherwise noted, copyright (and any other intellectual property rights, if any) in this publication is owned by the Commonwealth of Australia.

#### **Creative Commons licence**

With the exception of the Coat of Arms, ATSB logo, and photos and graphics in which a third party holds copyright, this publication is licensed under a Creative Commons Attribution 3.0 Australia licence.

Creative Commons Attribution 3.0 Australia Licence is a standard form license agreement that allows you to copy, distribute, transmit and adapt this publication provided that you attribute the work.

The ATSB's preference is that you attribute this publication (and any material sourced from it) using the following wording: *Source:* Australian Transport Safety Bureau

Copyright in material obtained from other agencies, private individuals or organisations, belongs to those agencies, individuals or organisations. Where you want to use their material you will need to contact them directly.

#### **Addendum**

Page	Change	Date

# Safety summary

## What happened

On 22 January 2018, a Sydney Trains passenger train (A42) failed to stop as intended at the Richmond Station platform, and collided with the buffer stop at the end of the platform at a speed of about 26 km/h. There were 26 people on board the train (including the driver and a guard). Sixteen people were injured and treated at the scene, some with serious injuries.

**A42 at Richmond Station**



Source: ATSB

## What the ATSB found

The ATSB's investigation found that the driver of A42 did not slow the train at a crucial time when approaching the buffer stop at the end of Platform 2 at Richmond Station. A number of possibilities for the driver's inaction were examined during the course of the investigation, these included: the driver blacking out, the driver experiencing a microsleep due to fatigue impairment, or the driver being distracted / inattentive. The investigation was unable to conclusively determine what caused the driver to have no control system input for 22 seconds shortly before impact.

The ATSB concluded that the buffer stop withstood the impact of the collision and prevented the train from crossing onto a main road. It further concluded that the two hydro-pneumatic rams on the front of the buffer stop did not perform as designed, due to non-alignment with the crash energy management system on the front of the Waratah train, and Sydney Trains' risk-management procedures did not rectify deficiencies in the buffer stop design at Richmond before the incident. The crash energy management system on A42 reduced the impact force of the collision but not all components performed as designed.

## What's been done as a result

The buffer stops for Platforms 1 and 2 at Richmond were redesigned. The new buffer stops are compliant with the NSW buffer stop standard. The NSW Asset Standards Authority (ASA) has reviewed and updated their buffer stop standard.

Other measures which may have prevented the collision, such as the installation of an intermediate train stops and automatic train protection, were not present at the time of the incident. Intermediate train stops, previously identified and recommended as a risk control, have been installed at Richmond since the incident. Automatic train protection which, if installed on A42, may have prevented the incident, was still in trial stage at the time of the incident. Transport for New South Wales (TfNSW) have scheduled automatic train protection to be operational on most Sydney Trains electric rolling stock by May 2021.

Computer modelling and analysis of the crash performance of the A-set and its crash energy management system has been undertaken. This will provide better understanding for future rolling stock specification and design.

## Safety message

Rail operators should ensure that multi-layered defences are in place against over-speeding. This should include infrastructure design, rolling stock design and train crew health management. They need to ensure that identified risk controls are implemented, and that these control measures are effective in their performance.

# Contents

<b>The occurrence</b> .....	<b>1</b>
Events prior to collision	1
The collision	3
Post-collision events	5
Site examination, recovery and repair	6
<b>Context</b> .....	<b>7</b>
Location	7
Organisation	7
Environmental information	8
Train crew	8
Train information	8
Track and infrastructure information	10
Rail head and train wheel inspection	13
Previous incidents	13
Safety actions implemented	14
Sydney Trains	14
Downer	14
Transport for NSW	15
<b>Safety analysis</b> .....	<b>16</b>
Introduction	16
Driver issues	16
Driver safety systems	21
In-cab audio and video recording	30
Buffer stop issues	32
Crashworthiness and crash energy management	39
Emergency response management	50
Organisational risk management	51
<b>Findings</b> .....	<b>54</b>
Contributing factors	54
Other factors that increased risk	54
Other findings	54
<b>Safety issues and actions</b> .....	<b>56</b>
<b>General details</b> .....	<b>60</b>
Occurrence details	60
Train details	60
<b>Sources and submissions</b> .....	<b>61</b>
Sources of information	61
References	61
Submissions	63
<b>Glossary</b> .....	<b>64</b>
<b>Australian Transport Safety Bureau</b> .....	<b>65</b>
Purpose of safety investigations	65
Developing safety action	65



# The occurrence

## Events prior to collision

The crew of the accident train, run 150-E, consisted of a driver and guard who had commenced duty in the early hours of 22 January 2018. The driver signed on at the Blacktown Depot at 0312<sup>1</sup> to commence his shift. He was due to finish at 1111. At the start of his shift, he first prepared a train in the Blacktown siding and then operated run 149-B from Blacktown at 0515, arriving at Richmond at 0552. Afterwards, he operated a return service to Blacktown arriving at 0645, and then travelled as a passenger on this same train to Central Station, arriving at 0729. The driver commenced a break until 0806 when he relieved another driver and operated run 286-D to Blacktown, arriving at 0843. The driver then had a meal break, walking into the main street of Blacktown to purchase and consume some food. He returned to the station, waiting on Platform 2 for run 150-E to arrive. Run 150-E had departed Central Station at 0834 and was due to arrive at Blacktown at 0917 where a crew changeover occurred (Figure 1).

**Figure 1: Location Map**

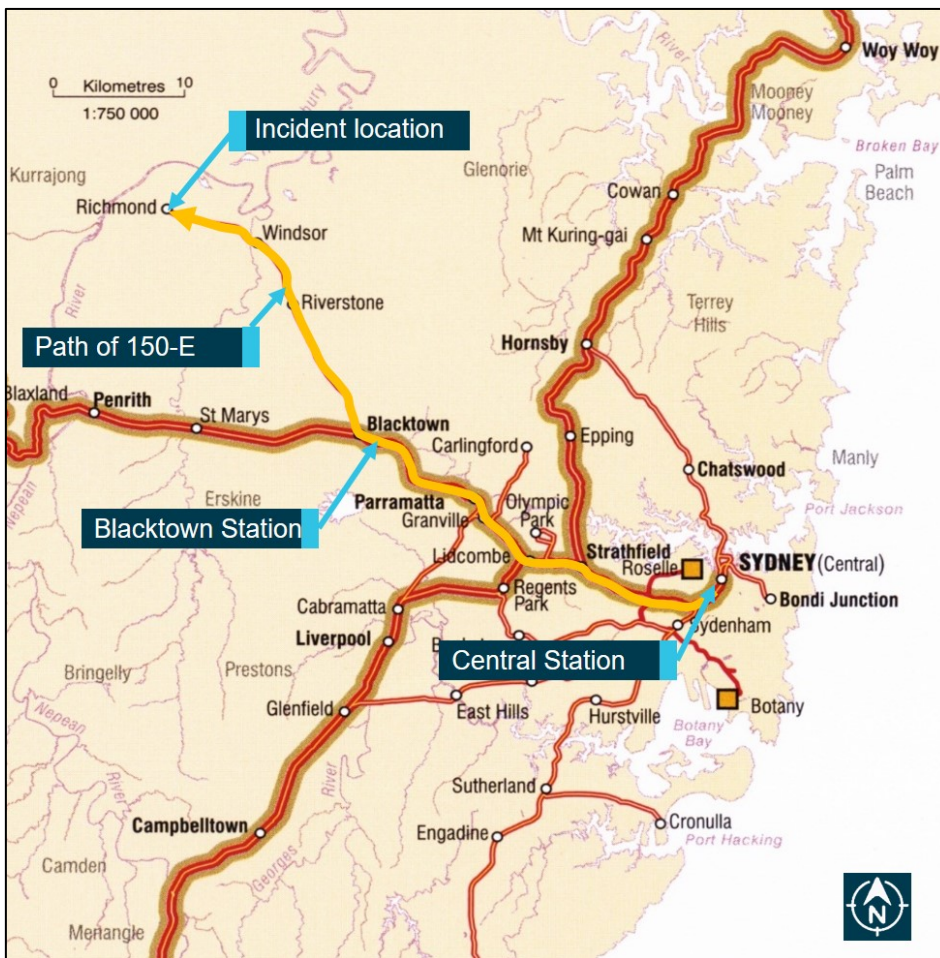

*This map shows the path of run 150-E from Central to Richmond Station and the major railway lines in the Sydney metropolitan area. Source: Geoscience Australia, modified by the ATSB*

The train arrived at 0917, as per the timetable. The outgoing driver verbally provided information about the state of the train. There were no faults reported by the outgoing driver. The driver took his seated position in carriage (car) 1, closed his cabin door, then received a ‘proceed’ bell signal

<sup>1</sup> The 24-hour clock is used in this report. Local time was Australian Eastern Daylight-saving Time (EDT). Coordinated Universal Time (UTC) + 11 hours.

from the guard. The train departed 2 minutes late, but was on schedule by the time it reached Clarendon, eight stations later.

The guard of the accident train had signed on at Richmond Station at 0243 and worked two Richmond to Blacktown return services and then a Blacktown to Schofields service before returning to Blacktown Station at 0851. The guard waited at the city end of Platform 2 for run 150-E to arrive. He did not speak to the driver while waiting for the train, nor at any time throughout the trip to Richmond. The guard received a handover from the outgoing guard and took his position in the compartment at the rear of the train, car 8.

After departing Blacktown Station at 0920, the train made eight stops before arriving at the last station before Richmond, East Richmond at 0950:10. The driver said the train was operating normally throughout the journey and that, up to this point, he was feeling fine and had no indication of any problem with his health. A tabular summary of the journey from Blacktown to Richmond is shown in Table 1.

**Table 1: Tabular summary of journey of 150-E, Blacktown Station to Richmond Station**

Station	Timetable	Max speed in section	Time of door opening	Time of door closing	Time driver powered on
Blacktown	0917- 0918		0919:27.4	0920:05.6	0920:09.9
		92 km/h			
Marayong	0920		0922:47.1	0923:01.5	0923:02.5
		83 km/h			
Quakers Hill	0924		0925:41.9	0926:00.0	0926:02.5
		107 km/h			
Schofields	0926 - 0927		0928:38.1	0928:56.2	0928:57.5
		99 km/h			
Riverstone	0930 - 0932		0932:07.1	0933:03.0	0933:06.4
		91 km/h			
Vineyard	0937		0937:11.6	0937:27.0	0937:28.4
		100 km/h			
Mulgrave	0940		0940:45.1	0940:57.4	0940:58.5
		<b>78 km/h</b>			
Windsor	0944		0944:07.6	0944:31.0	0944:33.0
		85 km/h			
Clarendon	0947 – 0948		0946:53.4	0947:07.4	0947:08.4
		92 km/h			
East Richmond	0951		0950:10.6	0950:25.0	0950:27.0
		<b>52 km/h</b>			
Richmond	0952		0951:46		

Source: Sydney Trains

The maximum speed was exceeded, momentarily, on two occasions. Between Mulgrave and Windsor, the maximum allowable track speed is 75 km/h and the train reached a speed of 78 km/h for a short period of 4.7 seconds. Between East Richmond and Richmond, the maximum allowable track speed is 50 km/h and the train reached a speed of 52 km/h for a brief period of 1.9 seconds.

Run 150-E departed East Richmond approximately 30 seconds ahead of timetable at 0950:27. The driver received a 'proceed' bell signal from the guard and, using the power/brake handle, increased power demand to 85% at 0950:29 (maximum power is 90%). This power level was maintained for 19.5 seconds until the train had reached a speed of 48 km/h. The driver then reduced power demand to 50% at 0950:48.5.

At 0950:48.9, the driver operated the train's town horn for 260 milliseconds on approach to the Bourke St level crossing. Due to the slight downhill track gradient of 1:77, the train increased speed to 52 km/h. The driver said that he could see the caution signal ahead and Richmond

Platform 2 in the distance. He said he was aiming for a smooth stop before the buffer at Richmond Station (Figure 2).

**Figure 2: Richmond Station and train path of 150-E**



Source: Google maps with annotations by ATSB

At 0951:06.1, the driver applied the power/brake control handle from 50% to brake (39%) just above the minimum brake demand level. The train was travelling at 52 km/h and the distance to the buffer stop was 270 m.

Somewhere past the home signal RD5, which displayed a green over red (caution) indication, but sometime after the action of applying the brake, the driver reported that he ‘felt dark, dizzy and powerless, and that my body had no control over me. I felt complete black, dark. I don’t know what happened to me after that.’ According to event recorder analysis from other similar trains, drivers usually make a number of brake applications during this time, which change the rate of deceleration.

The distance from the end of East Richmond platform to the start of Richmond platform is approximately 506 m; run 150-E took 46 s to travel this distance. As the train approached Richmond Station, the guard, who was preparing to finish his shift, had packed his bag and was standing near the door on the platform side of the train. He said he was looking at the internal CCTV screen as the train entered the platform. This screen displays multiple views from various cameras located in the passenger areas and on the train’s exterior.

Meanwhile, the passengers inside the train were preparing to disembark at this end-of-the-line stop. Many had left their seat and were making their way to, or were already in, the vestibule area near the doors. There was no announcement of the impending collision and the passengers had no warning that the train was about to collide with the buffer stop. There were 24 passengers and two crew members on board the train at the time of the collision. The majority of the passengers were in the front half of the train. There were seven passengers in car 1 and seven in car 2, two passengers in car 3, five passengers in car 4, two passengers in car 5 and one passenger in car 6.

### The collision

At 0951:15.6, the leading car of A42 passed the Sydney-end of Platform 2 at Richmond Station at a speed of 47 km/h. The train was timetabled to arrive at 0952. A42, under the effect of electro-



dynamic braking with brake cylinder pressure at zero, was decelerating slowly ( $\sim 0.2 \text{ m/s}^2$ ) as it travelled the approximate 168 m-length of Richmond Station.

The driver stated that when he regained his senses he reacted by applying the emergency brake. At 0951:28.1, the power / brake control handle was moved to the maximum brake position. There had been no control system input by the driver since 0951:06.1, 22 seconds before. The train's speed at this point was 36 km/h and the distance to the buffer stop was 27 m.

It was approximately a car length before the buffer stop that the guard realised there was a problem. This would have given him less than 2 seconds to activate the emergency brake, which meant that even if it was activated, the train would have still collided with the buffer stop. There were no early clues to alert the guard that there was a problem with the driver. The train had entered the platform at a normal approach speed and the train was decelerating slightly. In this situation, the investigation determined that there was insufficient time for the guard to react by applying the emergency brake in his compartment.

At 0951:29.5, the driver moved the power/brake control handle to emergency. The train's speed at this point was 34 km/h and the distance to the buffer stop was 17 m.

The first indication of the impact with the buffer stop is at 0951.31.1, when the Emergency Door Release Terminal Door Seal was recorded as having opened. This is the emergency door at the front of the train, which opens to the driver's compartment. The train's speed at impact was 26 km/h. The buffer stop stopped the progress of A42 and the impact sent a high deceleration shock pulse down the train.

After the impact with the buffer stop, the front of the train came to rest approximately 3 m from the buffer stop and the rear carriages recoiled further due to the partial recovery of the energy absorption elements that are distributed throughout the train. The impact caused all cars to concertina together, with some wheels lifting from the track. A post-incident inspection found, on the rear wheelset of the rear bogie on the third position car one wheel suspended above the rail, the other wheel derailed and all wheels of the rear bogie (No.1 end) on the fifth position car derailed.

There was damage to the front of the train, particularly the head of the Sharfenberg coupler (No.2 end of motor driving carriage D6342), the lower section of the front nose cone and the undercarriage. There was significant damage to the interconnecting areas between cars, the associated door systems and the coupling systems between cars. There was no visible damage to the interior of the driver's cab or to the internal passenger saloon areas. The emergency door at the front of the train had become ajar during of the collision. The exterior stainless steel skin of the carriages, apart from the areas between carriages, sustained no visible damage.<sup>2</sup> All carriage windows and exterior doors were undamaged. The exterior doors and opening systems were all functioning following the collision.

The collision caused substantial damage to the end-of-track buffer stop with a significant transverse crack opening at the corner of the base and the upright. The two hydro-pneumatic rams positioned on the front of the buffer stop also sustained damage (Figure 3).

---

<sup>2</sup> There are limitations of visual inspections. There is potential for damage to have occurred to the train's bodyshell not immediately apparent on a general qualitative visual inspection but may become evident using other inspection methods.



**Figure 3: Platform 2 buffer stop and front of A42**



*This figure shows the post-collision damage to the buffer stop on Platform 2 and the front of A42.*  
Source: ATSB

The guard was standing near the closed exterior door of the rear driver's / guard's compartment as the train entered the station. He said he was watching the train's CCTV surveillance screen. He became aware that the train braking was not slowing the train as it usually would. At the same time as he was thinking to apply the brake himself, the driver applied the power/brake handle to full brake application. The guard was thrown forward into the handrail on the leading bulkhead. The guard said he fell to the floor and had trouble breathing due to sustaining cracked ribs.

### Post-collision events

By 0951:38, the train had come to a complete stop. CCTV showed the guard at the open door of his compartment who then opened the passenger doors a few seconds later. The guard stumbled out onto the platform and crouched on his haunches clutching his ribs. He returned to his compartment and emerged later.

The driver stated that he was dazed but conscious following the collision. He remained in the lead driver's compartment until 0952:25, when he emerged to walk around the platform and then returned to the cab. When interviewed, he stated 'I was very shocked, disorientated and traumatised. I was trying to recollect and compose myself ... but I was in so much pain'. He sustained injuries to his arm, hip and head. His injuries were mainly on the right-hand side of his body.

The triple zero emergency line first received a call about the incident at 0952:52. At 0953:40, the station manager called the Rail Management Centre to inform them of the accident and request assistance. The station manager was on the platform, next to the buffer stop, at the time of the collision. All three branches of emergency services attended this event. NSW Ambulance were first to arrive on scene at 1002. Shortly afterwards, a NSW Police inspector assumed command of the site.

At 0953:44, the driver called the Rail Management Centre and informed them that his train had struck the buffer stop. He gave a coherent account of the situation. A relieving guard who had been waiting on the platform checked to ensure that the driver did not require immediate treatment and then left to help injured passengers.

Richmond Station staff and other Sydney Trains employees who were already on the platform were first to attend to the injured passengers and train crew. Some passengers emerged from the train after the train doors were opened by the guard. Others, too injured to move, were stretchered out by emergency services.

A total of 16 persons were injured as a result of the collision. Many were assessed and received treatment in Richmond Park, across the road from the station. Five persons were assessed as requiring immediate transfer to hospital. NSW Ambulance confirmed that 15 persons were transported to hospital for further treatment and assessment. The driver and guard were breath tested by police, both returned a negative result.

At 1045, the driver, after being treated for his injuries, was interviewed by NSW Police. Later he was transported to Blacktown hospital for observation and drug and alcohol testing. The results were negative.

## Site examination, recovery and repair

At 1145, once emergency services had completed evacuation of the injured, the ATSB formally took control of the site from NSW Police for the purpose of conducting safety investigations. The ATSB then inspected the train, the track, and the adjacent infrastructure including the buffer stop.

On 24 January 2018, the ATSB took possession of the event recorders and digital video recorders from the train while it was still at Richmond Station. Sydney Trains successfully relocated the cars to the storage siding where further assessment and temporary repairs of the cars occurred.

The train remained at Richmond until 2 February 2018 when the three rear cars (D6442, N5442, N5642) were coupled to a locomotive and hauled to the Downer<sup>3</sup> maintenance facility at Cardiff, Newcastle, New South Wales, approximately 150 km by rail from Richmond. Two more cars (T6642, T6542) were moved on 14 February 2018. The remaining 3 cars (D6342, N5342, N5542) were moved on 21 February 2018.

The initial response, recovery and transfer of A42 to Cardiff were coordinated between all parties including Downer, Sydney Trains and Transport for New South Wales. Sydney Trains is the operator of the train, Downer is the maintainer of the train, and TfNSW through the Asset Standards Authority sets standards for rolling stock and infrastructure.

At Cardiff, a number of non-intrusive inspections took place in which the damage to A42 was photographed and documented. Downer engineering specialists assessed the options for repair. All major components were removed and individually assessed for damage. Comprehensive testing and commissioning was undertaken by Downer with support from Sydney Trains.

A42 recommenced revenue service on 28 March 2019 following a 14-month repair effort. The total repair cost for A42 was approximately \$4.8 million.

---

<sup>3</sup> Downer is an integrated services company listed on the Australian Securities Exchange as Downer EDI. Business units within the Downer group includes EDI Rail PPP Maintenance and Downer Rail.

# Context

## Location

Richmond is a suburb of Sydney, located approximately 52 km northwest of the CBD. Richmond Station is a terminating station located 60.761 km by rail from Central Station. Behind the buffer stop was a pedestrian ramp, an overhead catenary stanchion, a pedestrian footpath and a four-lane road (Market St) (Figure 4).

**Figure 4: Richmond Station**

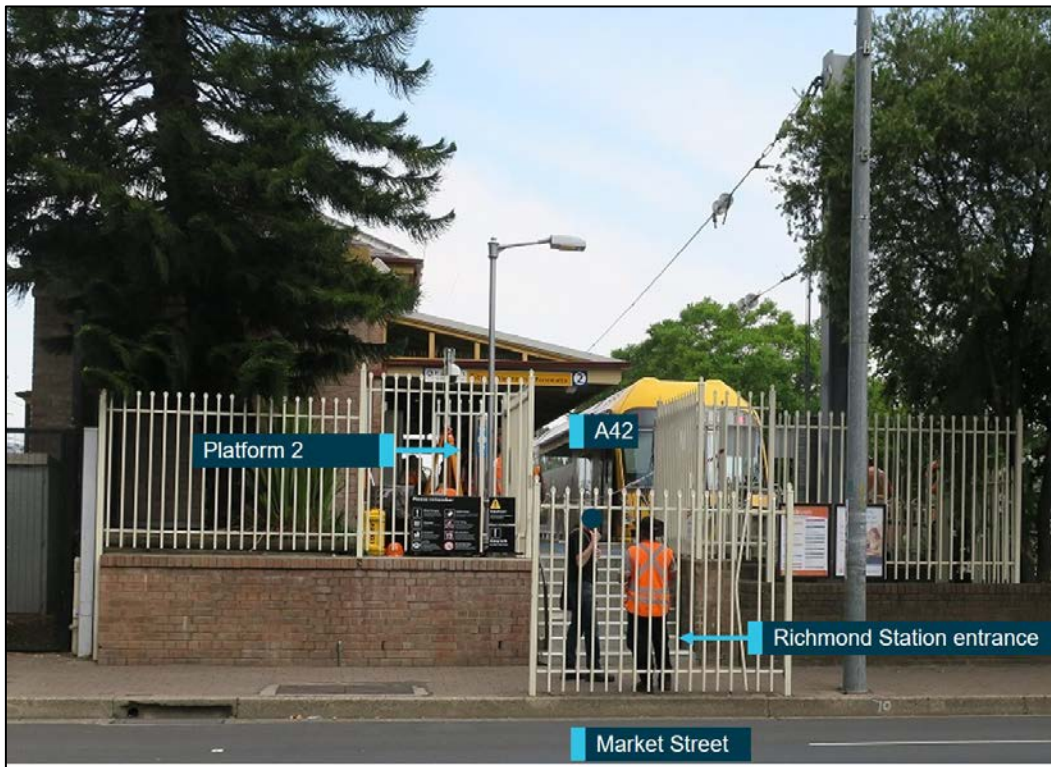

*This figure shows the street entrance to Richmond Station and the location of A42 post-collision in proximity with the pedestrian footpath on Market Street.*

Source: ATSB

## Organisation

Sydney Trains is the operator of rail services across metropolitan Sydney, operating passenger services in an area bordered by Berowra, Emu Plains, Macarthur, Richmond and Waterfall. It controls train movements on its network using signal control complexes and the Rail Management Centre. The Richmond rail line has passenger services at about 30-minute intervals during the peak period.

Sydney Trains started train operations as a legal entity on 1 July 2013 and was accredited as both a rail operator and infrastructure manager under the Rail Safety National Law (NSW) No. 82a. It inherited a number of staff, documents, systems, assets, responsibilities and duties from the previous operator, RailCorp. RailCorp, as an entity, remains the owner of real property, rail infrastructure and rolling stock, but its functions as operator and maintainer of metropolitan and interurban rail passenger services were transferred to Sydney Trains and another government agency, NSW TrainLink, for regional services.

## Environmental information

At 0900, on the day of the accident, the temperature was recorded at Richmond as 23.1°C. The overnight minimum temperature was 16.3°C. The nearest Bureau of Meteorology automatic weather station (AWS) was located at RAAF Base Richmond, about 3 km east of Richmond Station.

The previous four days all recorded a maximum temperature over 35°C and the temperature on the day of the accident eventually reached 42°C (five hours after the accident).

Sunrise on the day of the incident was at 0539 and it was a fine morning. The sun was behind and on the right-hand side of the train. The position of the sun was determined not to have affected the driver's visibility.

There had been no rain recorded at Richmond Station in the 11 days prior to the incident.

## Train crew

The train crew were both Sydney Trains employees. The driver was based at the Blacktown depot while the guard was based at the Richmond depot. Both lived in nearby suburbs and drove to work with less than 20 minutes' travel time to work.

The driver was an experienced driver who started as a guard in 2005 and progressed to become a metropolitan train driver in 2007. He had been assessed as medically fit in February 2014 and was not due to be reassessed until 2019. He was familiar with the route and had been qualified to drive Waratah sets since 2013.

The guard was an experienced guard, having started as a guard in 1985 and became a trainer guard in 2003. He was familiar with the route, being based at Richmond for 20 years, and had been qualified on Waratah sets since 2014.

## Train information

The train involved in the incident was called a Waratah train, also known as an A-set. Each 8-car Waratah set has a designated number, all beginning with the letter A. The train involved in the incident was A42. Sydney Trains operate the A-sets which are leased to Sydney Trains by Reliance Rail Pty Ltd under a Rolling Stock Manufacture Contract with Reliance Rail, a Downer/Hitachi Joint Venture was responsible for the design, manufacture and commissioning of the Waratah trains and train simulators. Under a Through Life Support Contract with Reliance Rail, Downer is responsible for the through life support of the Waratah trains, the Auburn maintenance centre and train simulators (Figure 5).



**Figure 5: Rolling Stock PPP Contract Structure**

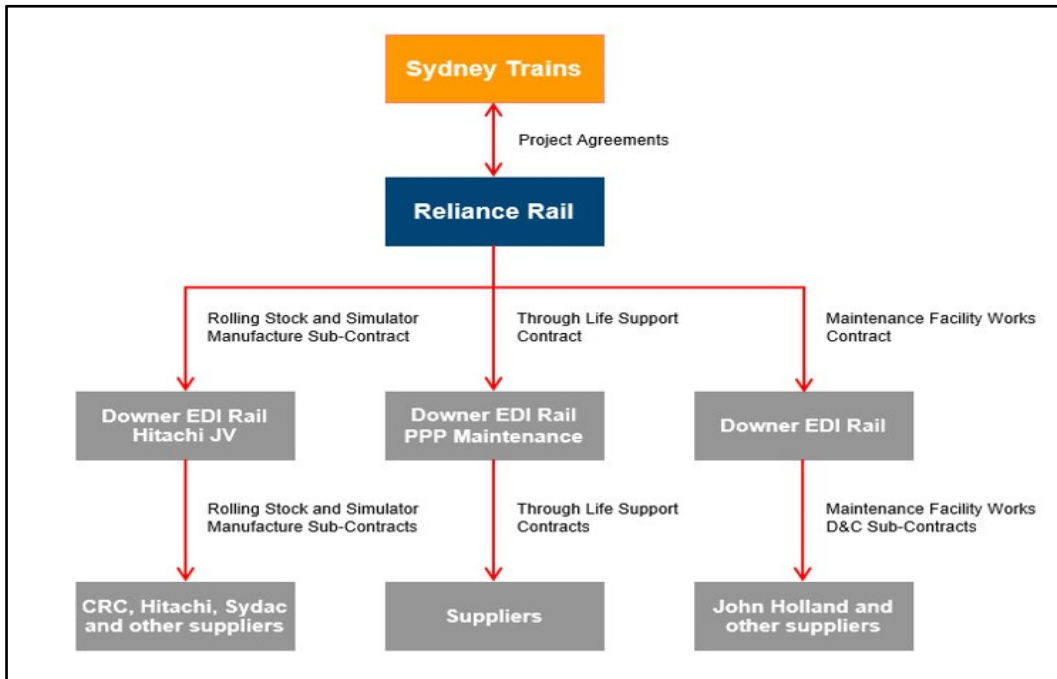

This figure shows the structure of Reliance Rail.  
 Source: Reliance Rail website, [Waratah delivery structure](#)

There are 78 A-sets in total, all are maintained at Auburn, in western Sydney. These trains first entered service on the NSW rail network in 2011, and the final set was delivered in May 2014. A42 came into service in May 2013.

A42 was a double-deck electric multiple-unit train, consisting of an eight-car set. It had a driving car at each end, two motor cars located next to each driving car, and two trailing cars in the centre of the train (Figures 6 and 7).

**Figure 6: A42 at Richmond Station post-collision**

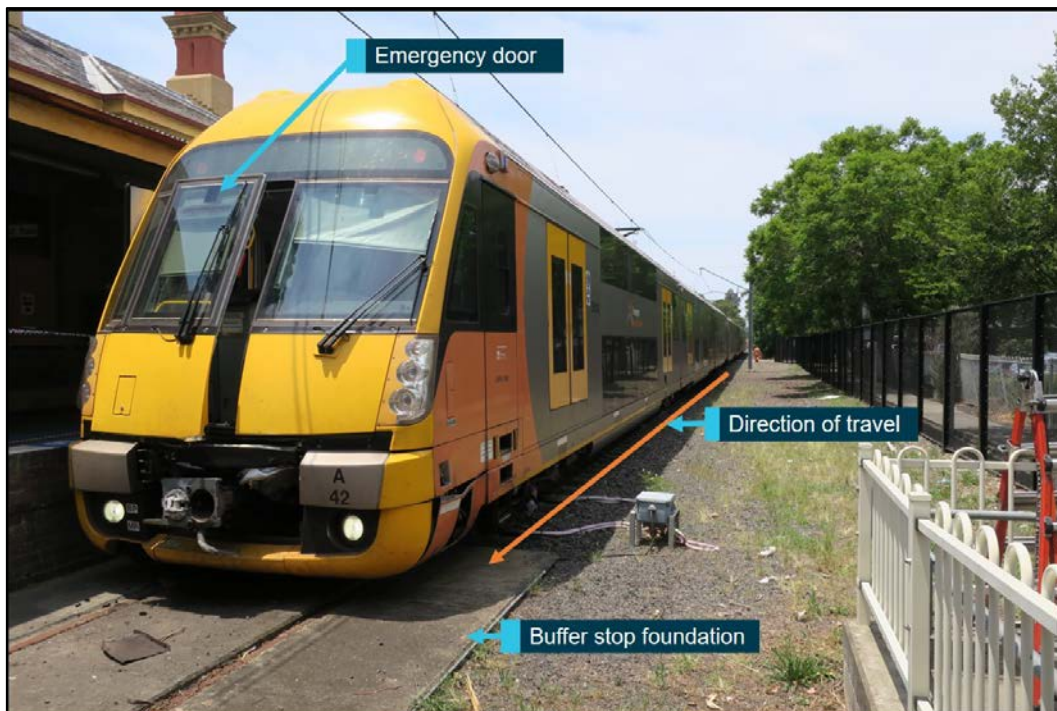

Source: ATSB

Figure 7: Waratah A-set car types

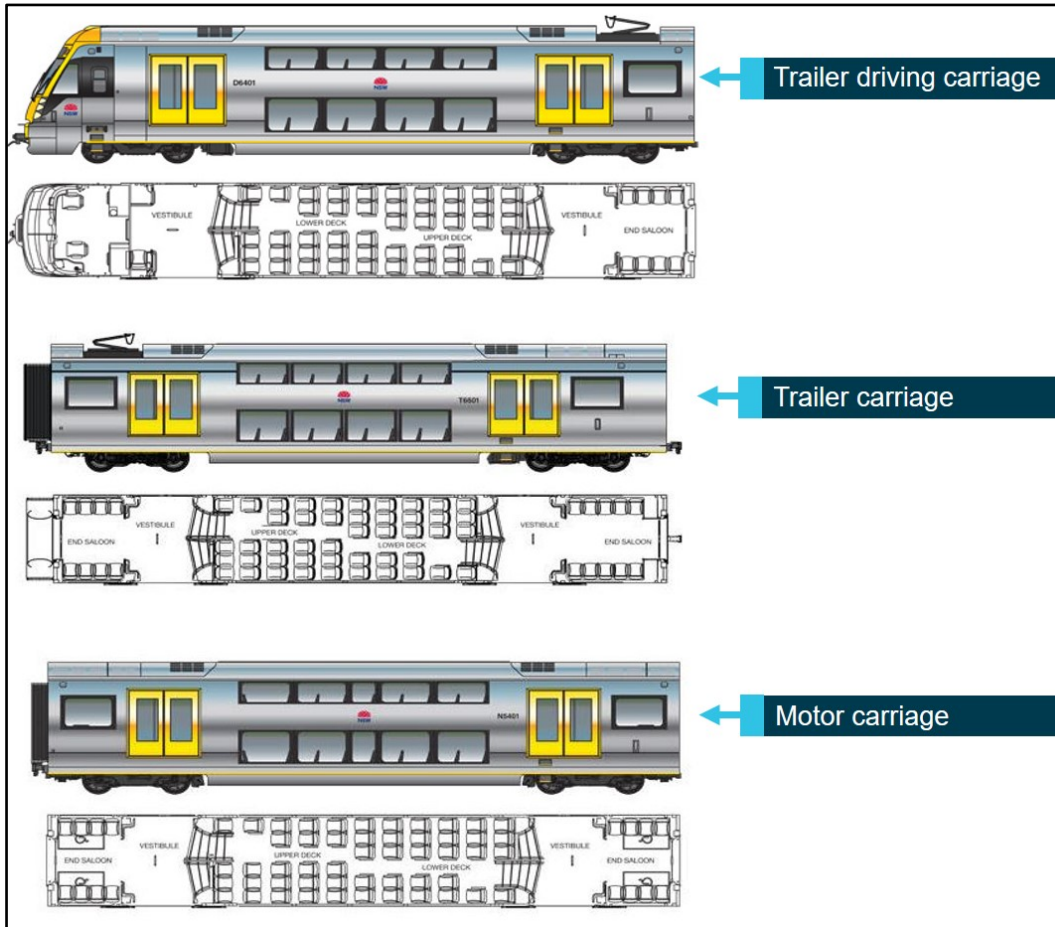

Source: Sydney Trains with annotations by ATSB

An eight-car Waratah set has a seated-passenger capacity of 896. The train width is 3035 mm, the height is 4410 mm, and each car is approximately 20 m in length. The total length of the train is approximately 163 m. It has a tare mass of approximately 407 t, a gross mass of 558 t. The Waratah was designed to be able to be operated at 130 km/h, although its maximum speed is restricted to 115 km/h. The train has a regenerative braking system with blended electro-pneumatic wheel-mounted disc brakes. The bodies of the cars are stainless steel with composite train ends.

The previous 30-day train examination was conducted on 27 December 2017 and the train was deemed fit for service. The train preparation certificate for A42 issued by Downer at the Auburn Maintenance Facility on 22 January 2018 stated the train was functioning as designed, and found the train fit for service.

## Track and infrastructure information

The track structure between East Richmond and Richmond consisted of 60 kg/m rail fastened to concrete sleepers with a bed of rock ballast. The track approaching Richmond Station had a falling gradient of 1:77 from about the RD 5 signal to just past the start of Platform 1, where the track grade transitioned to 1:660 into the buffer stop.

Track inspections showed no evidence of obvious track defects or misalignments. The track geometry measurements carried out before and after the collision found the track to be within tolerances and of sound alignment.

Richmond Station is the terminal stop on the Blacktown to Richmond single bi-directional line. This standard gauge railway line was opened in 1864. It is a branch line of the Main Western line. This electrified line is predominantly used by passenger trains and is a single track for much of its length. The line is duplicated at multiple positions along the track. Passing loops also exist at various stations, allowing for trains to pass.

Train movements on the Richmond line are controlled by Sydney Trains under network rule NSY 500 *Rail Vehicle Detection system*. This system of safeworking prescribes the rules used in axle counter territory and continuously track-circuited territory on the network. Train movements on the metropolitan network, including the Richmond line, are authorised by a Train Controller from the Rail Management Centre in Sydney. These movements are controlled in conjunction with local signal control rooms. At the time of the incident, the movements for Richmond were controlled by the Area Controller located in the Blacktown signal box. Both the Rail Management Centre and the Blacktown Signal Box are now in the Rail Operations Centre at Green Square.

Richmond Station consists of an island platform, incorporating Platform 1 and 2, which has an effective length of approximately 168 m<sup>4</sup>. A dead-end line runs on each side of this island platform. A third dead-end siding line (The Up<sup>5</sup> storage siding) is used to stable trains for storage purposes. All three lines were terminated with an identical buffer stop involved in the incident.

The single line from East Richmond Station to Richmond Station curves to the right for 160 m before straightening after the Moray Street pedestrian crossing. Once past this crossing, the line diverges into three separate lines to Platform 1, Platform 2 and the Up storage siding line. There is a clear line of sight to the buffer stop for Platform 2. The buffer stop also had a functioning light signal, which displayed a red light, centrally located on top of the buffer stop (Figure 8).

**Figure 8: Platform 2 buffer stop of Richmond Station**



*This diagram shows the post-collision damage to the buffer stop on Platform 2, details at Richmond Station, and the light signal attached to the buffer stop.*  
Source: ATSB

<sup>4</sup> The effective length of the platform was measured from the Up end of the platform to the head of the buffer stop ram.  
<sup>5</sup> Down lines typically carry train movements away from Sydney, Up lines towards Sydney.



A signal, RD5, and an interlocking set of points permits trains to travel straight ahead along the Platform 2 line, as was the case the morning of the incident, or to be diverted onto one of the other two lines.

The permissible posted speed for trains travelling in the section from East Richmond Station to Richmond Station is 50 km/h. At the time of the accident, there were no temporary speed restrictions in place in the section from East Richmond to Richmond.

The three buffer stops at Richmond Station were all of the same energy-absorbing design. Sydney Trains indicated that the buffer stops were installed in the early 1990s. They all had bodies constructed from steel-reinforced concrete with two oleo-type 15 MMO-2000-0104 hydro-pneumatic rams bolted to the face of the buffer stop. These rams were designed to assist in absorbing the energy of a collision with a train.

This type of buffer stop was a minority type on the Sydney Trains network, with the majority being of a fixed timber design. A high percentage of critical locations utilise energy-absorbing designs.

The last examination done on the Richmond Platform 2 buffer stop was by Sydney Trains on 2 April 2017. The buffer stop examination report did not list any defects or make any comment about its condition. The next scheduled examination was on 16 November 2020.

The overall dimensions of the L-shaped buffer stop was 6.45 m long, 3.5 m wide and 4.1 m high. The end stop portion of the buffer stop was steel-reinforced concrete, protruding 1.6 m vertically from the ground. The majority of the mass of the buffer stop was below ground level. The engineering approval drawing for the buffer stops at Richmond Station was dated 26 February 1991.

The hydro-pneumatic rams had a metal tag affixed to the end plate dated 3 September 1991 (Figure 9). These rams extend approximately 1.1 m from the face, with a hollow tubular area cast into the concrete behind the rams so that under impact they can collapse into this tube.

**Figure 9: Buffer stops, Platform 1 and Up storage siding, Richmond Station**

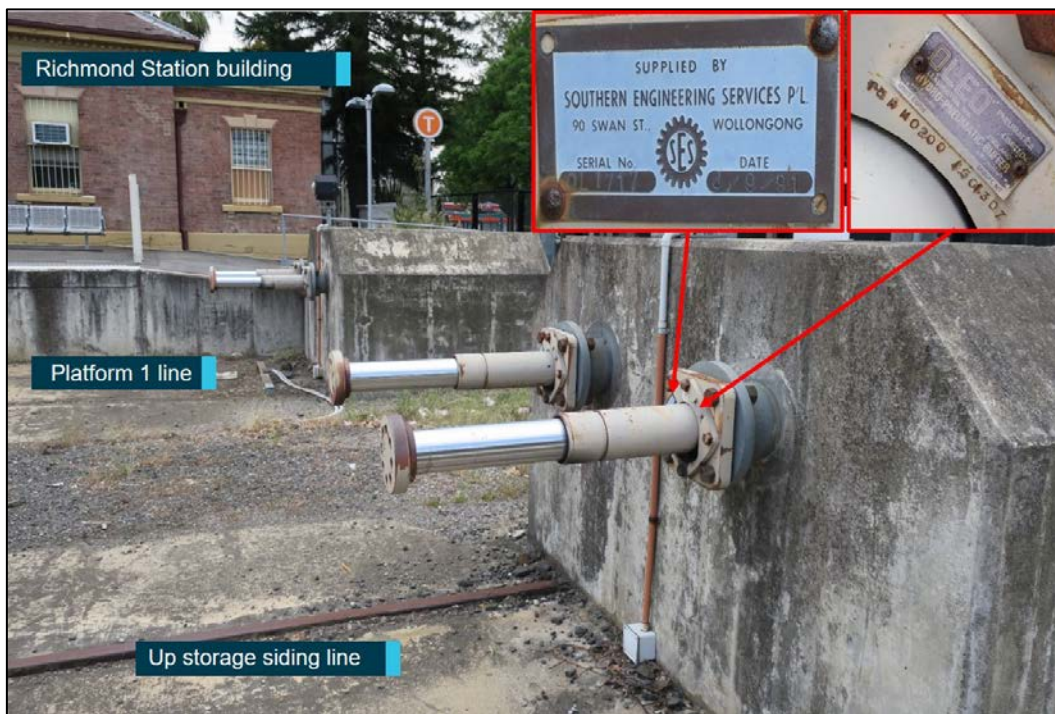

*This diagram shows the buffer stops at Richmond Station on the Up storage siding line (right) and Platform 1 line (left), the insert shows the identification tags on one buffer stop.*



Source: ATSB

### ***Rail head and train wheel inspection***

Leading up to the platform and under the train, the rail head was inspected for evidence of contaminants such as woody or leaf material, oils, grease, corrosion products, metals and other particles. The railhead appeared to have no significant degree of contaminants present.

There have been previous buffer stop collisions where contaminants have caused poor adhesion at the contact point between the train's wheels and the railhead. The investigation determined this was not the case at Richmond.

### **Previous incidents**

There have been a number of serious incidents involving passenger trains colliding with buffer stops, both in Australia and overseas.

The most significant recent Australian incident occurred on 31 January 2013, where a passenger train, T852, failed to stop at the Cleveland Station platform, in Brisbane, Queensland. The train collided with the buffer stop, the platform, and the station building at a speed of 31 km/h. A number of people were treated for minor injuries and transported to hospital for further examination.

The ATSB's investigation into the Brisbane accident found that local environmental conditions had resulted in the formation of a contaminant substance on the rail running surface. This caused poor adhesion at the contact point between the train's wheels and the rail head. The braking effectiveness of train T842 was reduced as a result of reduced adhesion and the train was unable to stop before hitting the buffer stop. It was found that Queensland Rail's risk management processes prior to the accident had not adequately assessed, recorded, managed and communicated the risks associated with operating trains on their network under low adhesion conditions.<sup>6</sup>

Later that year, on 16 September 2013, an eight-car V-set interurban passenger train collided at low speed with a buffer stop at Platform 10, Sydney Terminal. As the driver approached the buffer stop at the end of the platform, he misjudged the brake application. This brought his train to a stand just prior to the buffer stop. The driver then engaged power and increased the train speed to 10 km/h. Due to the close proximity of the buffer stop and the driver's application of the slower-acting automatic air brakes, the train collided with the buffer stop. There were no injuries to the passengers or the driver. An investigation found that the contributing factors to the collision was train management by the driver and electro pneumatic (EP) braking abnormalities. These abnormalities were experienced earlier on the trip and prompted the driver to switch off EP braking and run under the conventional air brake system.

On 6 December 2016, Sydney Trains' passenger service 625H collided with the buffer stop at the end of No.2 Platform at Cronulla when terminating. The Tangara train pushed the friction-type buffer stop back approximately 2 m. There were no injuries to the train crew or passengers on board the train. The investigation found that low adhesion caused by wet weather and rail lubricator grease contributed to the train not stopping as the driver expected.

Other buffer stop collisions have occurred at Sydney Terminal on 27 October 2017, 22 December 2017, and 18 February 2018. These three collisions all occurred at low speed with drivers misjudging the approach to the end of the platform. No injuries occurred and minor to nil damage was reported as a result of these incidents.

Overseas, in the US, two significant buffer stop incidents occurred: one in 2016 and one in 2017. On 29 September 2016, at Hoboken, New Jersey, an accident on the New Jersey Transit railroad

---

<sup>6</sup> ATSB rail investigation report (2013). RO-2013-005. *Collision of passenger train T842 with station platform at Cleveland, Queensland*. Published 20 December 2013.

killed one person, injured 110, and resulted in major damage to the station. On 4 January 2017, an accident on the Long Island Rail Road at the Atlantic Terminal in Brooklyn, New York, injured 108 people. Both accidents involved passenger trains that struck buffer stops and crashed into stations. The US National Transportation Safety Board (NTSB) investigation determined that the major contributory factor in both accidents was driver fatigue resulting from undiagnosed severe obstructive sleep apnea.<sup>7</sup>

## Safety actions implemented

A number of organisations have advised the ATSB that, in response to this incident, the following proactive safety actions have been implemented:

### **Sydney Trains**

#### Richmond Station

- A temporary speed restriction of 20 km/h, from East Richmond (60.200 km) to the buffer stops was put in place after the incident. Circuitry alterations were implemented so that the train stop on RD5 would provide a speed check at that point. Buffer stop redesign measures have been completed to meet compliance with the NSW Asset Standards Authority (ASA) buffer stop standard.<sup>8</sup>
- The new Platform 1 buffer concrete block was installed in April 2019. The Platform 2 buffer concrete block is planned for installation in January 2020. The buffers are planned for installation in February 2020.
- Sydney Trains has completed a signalling upgrade at Richmond, including intermediate train stops to control the approach speed. Planning has commenced for a platform extension at Richmond. Construction is expected to be completed in 2020.

#### Other locations and network-wide recommendations

- The remaining high-risk category locations (Central Platform 9, Macarthur, Carlingford) were assessed and speed reductions have been introduced in the short term to reduce the level of risk at these locations. Further control measures including intermediate train stops are being evaluated for installation at Macarthur and Central Platform 9 as part of the annual works program for 2019-2020. No further risk mitigation measures have been implemented at Carlingford due to the imminent closure of this line in January 2020.
- Sydney Trains' Asset Management Division has incorporated a program to assess and where appropriate upgrade buffer stops in its Annual Works Program, utilising the Buffer Stop Risk Index Prioritisation modelling for implementation sequence. Liaised with ASA to improve the process for issuing new infrastructure and rolling stock standards, adding a process where, through stakeholder consultation and risk assessment, existing equipment and its interfaces to the new standard/strategies are reviewed.
- Sydney Trains have created a centralised database for equipment concession against the issued ASA standards.

### **Downer**

- Downer have undertaken investigations into the performance of the A-set in the Richmond incident. They have also completed mathematical crash modelling to provide better understanding of the Richmond collision with respect to the design's ability to manage crash energy levels.

<sup>7</sup> National Transportation Safety Board (2017) *Special Investigation Report, End-of-track collisions at Terminal Stations Hoboken, New Jersey, 29 September, 2016 and Atlantic Terminal, Brooklyn, New York, 4 January 2017. NTSB/SIR-18/01.*

<sup>8</sup> T HR TR 25000 ST *Buffer Stops*, version 1.0, issue date: 10 July 2017.

## ***Transport for NSW***

A network-wide Automatic Train Protection project is underway. This, among other features, will provide speed control for electric passenger trains approaching buffer stops.

The ASA reviewed their buffer stop standard and updated it with a technical note<sup>9</sup> to include the following amendments:

- An explanation of the speed-related risk criteria to be considered during the buffer stop design stage.
- Amendments to the maximum allowable deceleration rate for lighter weight rolling stock while complying with the allowable impact force requirements.
- Amended maximum allowable impact force requirements that the newer generation trains can withstand with minimal damage or injury.

---

<sup>9</sup> ASA Technical Note –TN 033:2018 Amendments to T HR TR 25000 ST *Buffer Stops*, version 1.0. Issue date 21 December 2018.

# Safety analysis

## Introduction

On Monday 22 January 2018, train A42 approached Richmond Station with a train crew comprising a driver and a guard and with 24 passengers on board. The train entered the platform under the posted speed limit of 50 km/h but did not slow as expected and collided with the buffer at an estimated speed of 26 km/h. The evidence obtained from the train's event recorders confirm that the driver did not have any input to the controls for the period of 22 seconds from 0951:06 to 0951:28.

The buffer stop collision was the result of a lack of braking input by the driver as the train approached the buffer stop on Platform 2 at Richmond Station. The analysis section of this report explores the human factors surrounding the driver's performance and likely reasons for his lack of braking input.

The buffer stop withstood the impact of the collision and prevented the train from continuing into the street. The two hydro-pneumatic rams positioned on the front of the buffer stop were not aligned with any structural element on the front of the train, this meant they had little or no effect in the absorption of energy from the collision.

Other elements discussed in the analysis section include:

- driver safety systems
- buffer stops
- crashworthiness and crash energy management systems (CEMS)
- emergency response management
- management of safety risks.

The following elements were excluded from further analysis:

- the train's braking and control system
- track adhesion and track-related issues
- signalling and train control issues
- the actions of the guard.

## Driver issues

There is a risk with the operation of any vehicle that the operator may perform in a sub-optimal way. On passenger trains, there are many procedural and engineering defences put in place to mitigate this risk. These defences include: training, rostering, vigilance devices, operator enable (deadman) systems, train stop/trip gear systems, and the guard. The introduction of technology such as Automatic Train Protection in future will provide an additional defence.

The driver of A42 was interviewed by the ATSB on two occasions and was questioned closely about the events of that day, his previous shifts, and any aspect that may have potentially affected his behaviour on the day of the collision. The driver stated that he was feeling well and everything was normal leading up to, and during, the shift. He said he was well-rested, had slept well before his shift, had eaten normally, was hydrated and was feeling comfortable in the cab of the train. The driver had just had a break at Blacktown station less than an hour before the incident.

The driver was certified as medically fit in accordance with the *National Standard for Health Assessment of Rail Safety Workers (Health Assessment)*. Under this standard, rail safety workers such as the driver must have a valid certificate of fitness to perform rail safety work. The driver last had his category 1 medical assessment in February 2014. He was passed as 'Fit for Duty – unconditional'. This certificate was valid until April 2019. In addition to this compulsory medical,



the driver said he had a voluntary annual medical check with his local general practitioner. At the initial ATSB interview in February 2018, the driver stated that he was a person in good health, using no medication, with no previous history of blackouts or sleep disorders.

The health assessment standard covers a wide range of medical conditions that may impact on safe working performance. It seeks to provide guidance to support consistent assessment and decision-making. It is reviewed approximately every 5 years to ensure the medical criteria are up to date with the latest knowledge and research. The areas of interest to this investigation are contained in part 18 of the standard – ‘Conditions causing sudden incapacity or loss or situational awareness’. The following are the sub-headings for this part:

- Blackouts
- Cardiovascular conditions
- Diabetes
- Neurological conditions
- Psychiatric conditions
- Sleep disorders
- Substance misuse and dependence.<sup>10</sup>

The investigation considered the following were the most likely reason for the driver’s lack of input to the braking controls as he approached the buffer stop:

- the driver experienced a blackout
- the driver had a microsleep due to fatigue impairment
- the driver was inattentive or distracted.

Due to the lack of any CCTV inside the cab, the investigation could not conclusively determine what happened to the driver. The following is an analysis of the likely reason for the lack of braking input by the driver as the train approached the buffer stop.

#### ***Blackout due to an undiagnosed medical condition***

A blackout is described as an unpredictable, spontaneous loss of consciousness. The *National Standard for Health Assessment of Rail Safety Workers* states that ‘blackouts or pre-syncope may indicate an underlying medical condition (e.g. seizures, diabetes, cardiovascular condition, a sleep disorder)’.<sup>11</sup> It is possible that the blackout was related to the obstructive sleep apnea that the driver was diagnosed with after the incident. As described previously, the medical testing conducted on the driver after the event found no abnormalities with the driver’s cardiological or neurological condition.

One type of blackout is termed ‘syncope’. This temporary loss of consciousness is usually related to insufficient blood flow to the brain. It is commonly referred to as fainting or passing out. It often occurs when blood pressure is too low and the heart does not pump enough oxygen to the brain.

‘Fainting is a common problem, accounting for 3% of emergency room visits and 6% of hospital admissions. It can happen in otherwise healthy people. A person may feel faint and lightheaded (pre-syncope) or lose consciousness (syncope).’<sup>12</sup>

The driver’s original description of the event leading up to the collision was similar to that which can occur with low blood pressure. In the crucial time approaching the station the driver stated that he ‘felt dark, dizzy and powerless, and that my body had no control over me. I felt complete black, dark. I don’t know what happened to me after that.’ He also said that when he regained his senses he saw the buffer stop about one car-length away, and applied the brakes to maximum.

<sup>10</sup> National Transport Commission (2017). *National Standard for Health Assessment of Rail Safety Workers*. p.72.

<sup>11</sup> National Transport Commission (2017). *National Standard for Health Assessment of Rail Safety Workers*. p.72.

<sup>12</sup> <https://www.webmd.com/brain/understanding-fainting-basics#1>

It is considered possible that the driver experienced a pre-syncope or syncopal episode. It is reported that up to 50% of the population will lose consciousness at some point in their life due to a syncopal episode.<sup>13</sup> Sydney Trains agrees with an independent medical assessment that, considering all of the medical information, the most likely diagnosis was a blackout of undetermined cause.

### **Microsleep due to fatigue impairment**

In the context of human performance, fatigue is a physical and psychological condition primarily caused by prolonged wakefulness and/or insufficient or disturbed sleep.<sup>14</sup> Fatigue can have a range of influences on performance, such as decreased short-term memory, slowed reaction time, decreased work efficiency, reduced motivational drive, increased variability in work performance, and increased errors of omission.<sup>15</sup> Transport accident investigation agencies have identified fatigue impairment as a contributory factor in many accidents and incidents.

Extensive medical tests, including neurological and cardiology tests, were conducted on the driver following the incident. One test detected a problem. A sleep test (a home polysomnography sleep study) conducted in July 2018 led to the driver being diagnosed with moderate obstructive sleep apnea. This was followed by an in-clinic test on 8 October 2018 that showed mild obstructive sleep apnea and a maintenance of wakefulness (MWT) test conducted on 9 October 2018 that was normal, with no suggestion of sleepiness. He was advised by his medical practitioner to use a continuous positive airway pressure (CPAP) machine. In December 2018, the driver reported that since using the CPAP machine, his overall feeling of well-being had improved. He was unable to say if he was feeling more alert although he had not resumed train-driving duties.

Research has shown that sleep apnea increases the accident rate in motor vehicle drivers between two and seven times due to sleepiness and/or due to altered blood gases and hypoxia affecting mental function.<sup>16</sup> Obstructive sleep apnea involves repetitive obstruction to the upper airway during sleep. Throughout the sleep period, the breathing of a person can stop from a few seconds to over a minute. These episodes, which can occur many times during the night, are known as apneas. The person can be unaware that it has happened during the night but will frequently wake feeling tired. An increase in sleepiness can result from obstructive sleep apnea.<sup>17</sup>

It is possible that the driver was fatigued and experienced a microsleep. A microsleep is a very short period of sleep when the brain disengages from the environment and slips uncontrollably into light non-REM sleep.<sup>18</sup> Microsleeps have been shown to correlate with periods of low performance and they occur most frequently during conditions of fatigue.<sup>19</sup> It is possible the driver experienced a microsleep due to an increased level of fatigue due to a combination of obstructive sleep apnea, a cumulative lack of sleep, and an early morning shift start.

Even though the driver stated that he felt normal on the day of the incident, research has shown that patients with sleep disorders may not be aware of an impending sleep episode<sup>20</sup> and that there may be a lack of realisation by a sleep-deprived person as to how fatigued they actually are.<sup>21</sup> This driver had not reported any clinical features of sleep apnea prior to the incident and

<sup>13</sup> Stichting Elilpesie Instellingen Nederland (SEIN) (2019) *The blackout checklist*.

<sup>14</sup> National Transport Commission (2008). *National Rail Safety Guideline. Management of Fatigue in Rail Safety Workers*. p.5.

<sup>15</sup> Battelle Memorial Institute (1998). *An Overview of the scientific literature concerning fatigue, sleep, and the circadian cycle*. Report prepared for the Office of the Chief Scientific and Technical Advisor for Human Factors, United States Federal Aviation Administration.

<sup>16</sup> National Transport Commission (2017). *National Standard for Health Assessment of Rail Safety Workers*. p.142.

<sup>17</sup> Pack A, Pack AM, Rodgman E, Cucchiara A, Dinges DF, Schwab CW. *Accident Analysis and Prevention*. Vol. 26. (1995) *Characteristics of crashes attributed to the driver having fallen asleep*. p.769.

<sup>18</sup> Civil Aviation Safety Authority Australia (2014). *Bio-mathematical fatigue models – Guidance document*. p.64

<sup>19</sup> Transportation Safety Board of Canada (2014) *Guide to investigating sleep-related fatigue*. p.25.

<sup>20</sup> Desai AV, Ellis E, Wheatley JR, Grunstein RR. *Medical Journal of Australia*. Vol. 178. (2003). *Fatal distraction: a case series of fatal fall-asleep road accidents and their medicolegal outcome*. p.339.

<sup>21</sup> Folkard S, Robertson KA, Spenser MB (2006). *The development of a fatigue / risk index for shiftworkers*. p.12.

had no high-risk factors, such as a body mass index greater than 40, which would trigger a referral for a sleep study.

Sydney Trains, like other Australian rail operators, is not required to automatically send all employees in safety-sensitive positions for a sleep study. The *National Health Standards for Health Assessment of Rail Safety Workers* specifies certain criteria for sleep study referral and the driver of A42 did not meet these criteria.<sup>22</sup>

Another factor that increased the likelihood of a microsleep was that the driver had been awake since 0215, more than 7 ½ hours prior to the time of the incident. It has been reported that both feelings of fatigue and the occurrence of microsleeps increase as duty time progress.<sup>23</sup> The National Transport Commission recognises that the duration of a duty period is a contributor to fatigue-impaired work performance.<sup>24</sup> Early morning shifts are associated with high levels of fatigue and this can affect performance for the duration of the shift.<sup>25</sup> Also, some research has shown that shifts ending around the time of this accident show an increase in mental tiredness for train drivers.<sup>26</sup>

The driver was rostered to have 3 days off (Friday, Saturday and Sunday) before the incident day, Monday. Instead, he was phoned on Friday by the roster clerk and asked to work an overtime shift the next day, Saturday. He said he worked from 1500 to 2300 on Saturday and went to bed at 0200 in the early hours of Sunday morning. He awoke at 0830, having slept approximately 6 ½ hours.

The driver said he was used to early morning shifts and he would rather have not worked the afternoon/evening shift on Saturday. This change in shift meant that he changed his sleeping pattern from going to bed in the late evening (2130-2200) for the previous 5 days, to going to bed in the early hours of Sunday morning.

On Sunday, instead of resting at home and taking the opportunity for an afternoon nap, the driver went shopping with his family from approximately 1300-1630. Originally, the driver thought that he had napped that afternoon but an analysis of mobile phone records showed otherwise. The driver went to sleep Sunday evening at 2000 and set an alarm for 0215. The driver had the opportunity for approximately 6 hours sleep the night before the accident, and 6 ½ hours sleep in the previous 24-hour period. Research has shown that limiting sleep to six hours or less over successive nights can result in a deficit in performance<sup>27</sup> and that sleep of only six continuous hours is associated with an elevated likelihood of a fatigue-related incident.<sup>28</sup> It is suggested that the average amount of sleep required per 24-hour period for most people is approximately 8 hours.

There were two opportunities for the driver to increase his sleep hours. Firstly, after he completed his Saturday shift at 2300 when he did not go to bed until 0200. It is accepted that often people need a period of time to wind down after work before going to bed, but the 3 hours taken this evening may have been detrimental. Secondly, during the day on Sunday, he did not take the

---

<sup>22</sup> The NTSB, in their 2019 *Most Wanted List*, has targeted reducing fatigue-related accidents as a priority. It is noted that the Board has recommended the Federal Railroad Administration to require rail operators to screen employees in safety-sensitive positions for sleep apnea or other sleep disorders. National Transportation Safety Board. *Most Wanted List of transport safety improvements 2019-2020*. [www.nts.gov/mostwanted](http://www.nts.gov/mostwanted)

<sup>23</sup> UK Rail Safety and Standards Board (2004). *Human Factors study of fatigue and shift work. Appendix 1: Working patterns of train drivers implications for fatigue and safety*. p.66.

<sup>24</sup> National Transport Commission (2008). *National Rail Safety Guideline. Management of Fatigue in Rail Safety Workers*. p.5.

<sup>25</sup> Folkard S, Robertson KA, Spenser MB (2006). *The development of a fatigue / risk index for shiftworkers*. p.17

<sup>26</sup> UK Rail Safety and Standards Board (2004). *Human Factors study of fatigue and shift work. Appendix 1: Working patterns of train drivers implications for fatigue and safety*. p.65.

<sup>27</sup> Folkard S, Robertson KA, Spenser MB (2006). *The development of a fatigue / risk index for shiftworkers*. p.12.

<sup>28</sup> Stutts JC, Wilkins JW, Osberg JS, Vaughn. *Driver Risk Factors for Sleep-related Crashes, Accident Analysis and Prevention*, 2003.

opportunity to have an afternoon nap as he was in the habit of doing. Prophylactic napping has been shown to be beneficial in supplementing sleep time and reducing the effects of fatigue.<sup>29</sup>

### **Rostering**

Sydney Trains' rostering, fatigue-management and health policies were examined to determine if they contributed to the incident. The investigation found that while Sydney Trains had policies and systems in place to ensure that drivers were fit for duty and rostered in a manner to manage their fatigue levels, there were some inconsistencies with the rostering of this driver and Sydney Trains' operating procedure for managing shift work and rostering.

Sydney Trains' operating procedure was to 'make sure there are adequate breaks between shift cycles. Days off should be a minimum of two consecutive days'. Prior to the incident the driver had worked 5 consecutive days and then had a break of one day, worked another day, then had a one day break.

Another rostering principle inconsistent with the driver's roster was that start times should be consistent and move in a forward rotation. This driver had start times that moved from a regular morning start (0600-0700), to a single overtime shift that started at 1500, then to a very early morning start of 0312.

Sydney Trains' management systems provide guidance for management and employees to ensure there is an awareness of countermeasures in this area. The procedures are detailed and cover eventualities such as shift changes.

Sydney Trains use a bio-mathematical fatigue modelling program known as the Fatigue Audit Interdyne (FAID) to assess the suitability of the roster for managing fatigue risk. Bio-mathematical models attempt to predict the effects of different working patterns on subsequent job performance, with regard to the scientific relationships between work hours, sleep and performance.<sup>30</sup> The FAID score predicts the risk of fatigue associated with the opportunities provided by the organisation for an individual to obtain restorative sleep.<sup>31</sup> Guidance suggests that scores between 80 and 100 have a high fatigue likelihood. The FAID score for the driver on the day of the incident was 51. Other bio-mathematical scores were also calculated for the driver's shift. These also indicated that the driver was in the low range for being at risk of fatigue. However, any bio-mathematical model cannot account for the hours of sleep actually achieved by individuals, nor for the quality of that sleep.

### **Driver distraction / inattention**

Driver distraction and inattention are major contributing factors in accidents. While there are many differing definitions for distraction and inattention, for the purposes of this investigation the following definitions will apply:

'Distraction: a diversion of attention from the driving task that is compelled by an activity or event inside the vehicle.'<sup>32</sup> External events outside the vehicle can also provide a distraction.

'Inattention: insufficient or no attention to activities critical for safe driving.'<sup>33</sup>

It may be possible to be inattentive even where there is no distracting event.

The driver said that he was not distracted by any radio calls or external events and was paying attention as he approached Richmond Station. He said that he had driven into this station on hundreds of occasions and knew that the approach to the buffer stop was a critical time to apply

<sup>29</sup> Folkard S, Robertson KA, Spenser MB (2006). *The development of a fatigue / risk index for shiftworkers*. p.39.

<sup>30</sup> Dawson D., Noy YI, Harma M, Akerstedt T, Belenky G. (2011). *Modelling fatigue and the use of fatigue models in work settings*. *Accident Analysis and Prevention*, 43, p. 551.

<sup>31</sup> *Ibid.*, p. 553.

<sup>32</sup> Senders JW. (2013) *Driver distraction and inattention: a queueing theory approach*. *Driver distraction and inattention*. *Advances in Research and Countermeasures*. Ashgate. p.55

<sup>33</sup> Regan MA, Strayer DL. (2014) *Towards an understanding of driver inattention: taxonomy and theory*. *Journal of the Association for the Advancement of Automotive Medicine*.



the brakes in order to come to a smooth stop. He said that he was not using his mobile phone, and the phone records confirm that no messages or calls were made or received in the time leading up to the event. There was no one else in the cabin with the driver.

There is no evidence of distraction to the driver and in the absence of any in-cab CCTV footage, the investigation could only rely on the testimony of the driver and the recorded actions on the event recorder. On all occasions, from his initial conversations with the replacement guard, the train guard, and the police, to his formal interviews, the driver's recollection was consistent: that he did not know what happened to him but experienced some kind of blackout.

### ***Previous driving behaviour***

The driver's operation of the train and the performance of the train were analysed for the duration of the journey from Blacktown to Richmond. The driver's actions were found to be generally in line with the performance standards set down by Sydney Trains. The only area of concern was the previously described over-speeding events where the driver exceeded the maximum speed for the section of track on two occasions. These infractions were for a few kilometres per hour above the limit for a few seconds.

The driver's train driving history was examined for any previous similar incidents since commencing driving trains. Since starting as a driver in November 2007, there were eight recorded incidents where the driver has either failed to stop at a station, overshot the platform or passed a signal at stop. A variety of reasons are recorded for these lapses: distracted, misjudged, lost situational awareness and lost concentration. On each occasion, Sydney Trains has counselled or coached the driver to be more vigilant and to maintain situational awareness. Sydney Trains was unable to say if this was an above-or below-average error rate for drivers. This investigation made no determination on the driver's recorded error rate but includes it in the report for completeness.

## **Driver safety systems**

Rail operators use a range of measures to reduce the risk of driver error. This section will focus on the technology-based devices that may have prevented or mitigated the effects of this collision. These devices include:

- a vigilance control system
- an operator enable system
- a train stop and trip gear system
- an automatic train protection system.

The first three measures were already in use on the Sydney Trains network and on A42 at the time of the collision at Richmond. The last measure, automatic train protection, was not in use on the network at the time of the collision.

ASA have published a standard for train (driver) safety systems.<sup>34</sup> This standard applies to Sydney Trains and rolling stock operating on the Sydney metropolitan rail network. The standard covers onboard safety systems that protect train safety in the event of a failure in the manual functions of train operation, such as the driver becoming incapacitated approaching a buffer stop. Another ASA specification for passenger rolling stock driver safety systems provides greater detail for the application of these systems.<sup>35</sup>

<sup>34</sup> Asset Standards Authority. *Train (Driver) Safety System, T HR RS 00840 ST, v2.0*, issued 4 November 2016.

<sup>35</sup> Asset Standards Authority. *Passenger Rolling Stock Driver Safety Systems, T HR RS 20003 SP, v1.0*, issued 3 July 2015.

### ***Vigilance control system***

This system supports driver alertness and is in place to ensure the driver is maintaining vigilance at the controls. The standard for train (driver) safety systems defines a vigilance control system as a 'system that will react by bringing a vehicle or train to a stand if an acknowledgment input is not received within a specified time increment. On conventional vehicles with an automatic brake, the vigilance system will bring the train to a stand by directly venting the brake pipe to atmosphere'.<sup>36</sup>

All Sydney Trains passenger trains have onboard task-linked vigilance devices which are set up to warn the driver and apply an automatic brake application if there is no acknowledgement by the driver in the vigilance time cycle. The acknowledgement tasks include: pressing the vigilance button, applying the horn, operating the windscreen wiper, operating the power/brake control handle, operating the headlights/fog lights and also depressing the operator enable pedal. For each of these tasks there are parameters applied to the detection. For example, if the control input for the vigilance is the headlights or the foglights, it can only be used for one reset of the cycle then another type of input must be used.

The vigilance system is operational only at the active end of the train, so is only available for the driver and not the guard. It commences operation only when the power/brake control handle is moved out of the isolate position and when either the brake cylinder pressure is below 75% full service brake cylinder pressure or the speed is greater than 5 km/h.

The vigilance system has a 30-second cycle; if the driver does not perform one of the tasks within the cycle then the vigilance penalty sequence begins. Firstly, a warning light flashes on the control board in front of the driver and on the vigilance button itself, the driver is required to acknowledge the visible warning within 5 seconds or the sequence will progress to the next stage. Then, during the next 5-second period, a bell also sounds and the driver is required to acknowledge within the 5-second period or the sequence will progress to the automatic brake application. If no action is taken by the driver, an automatic brake application is initiated which cannot be released until 3 seconds after the train comes to a stand.<sup>37</sup> Following this, within the next 30 seconds, the driver can release the automatic brake by pressing the vigilance button. In the event of the driver failing to press the vigilance button within 30 seconds of the reset indicator, a distress message will be sent via the train's radio to train control and the train's park brakes will be applied (Figure 10).

---

<sup>36</sup> *Train (Driver) Safety System*, Op.Cit. p.10.

<sup>37</sup> Sydney Trains / Downer, *Brakes RTM00001-100B*. p.61.

**Figure 10: Vigilance control system timing sequence**

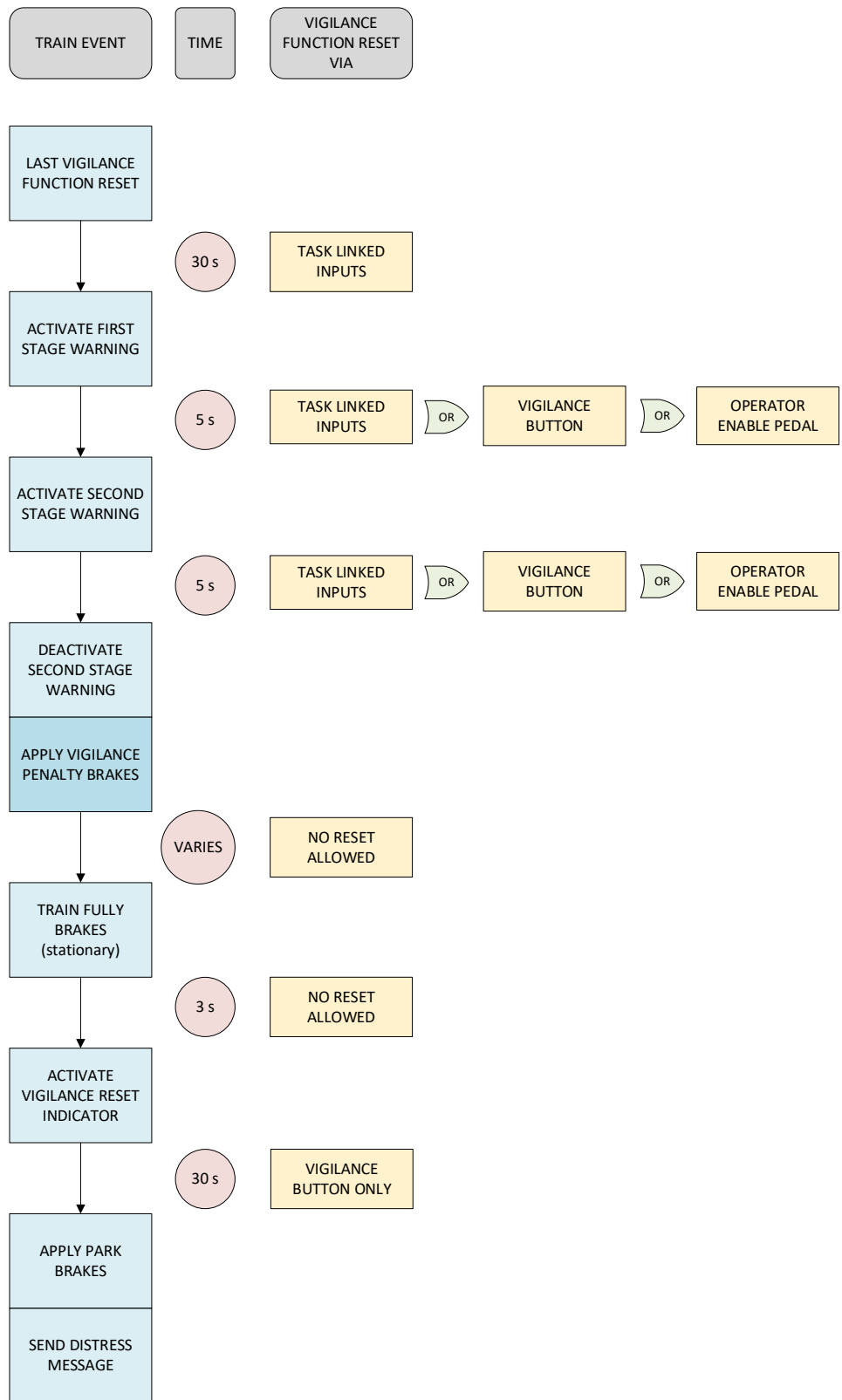

This figure shows the timing sequence of the train's vigilance system.  
 Source: ASA Passenger rolling stock driver safety system, modified by ATSB

Following the incident, the vigilance system on A42 was tested by a Sydney Trains brake engineer. This test was witnessed by ATSB investigators. The vigilance control system cycles were timed and tested and performed as designed. All elements of the vigilance control system

were operational and the event recorder showed that the driver was using the system throughout the journey from Blacktown that day.

The critical time that the driver was inactive on approach to the buffer stop was approximately 22 seconds. The investigation determined that this period of inactivity by the driver, with a possible loss of consciousness, occurred between a 30-second vigilance cycle.

### ***Operator enable system***

Another driver safety system is the operator enable system. Its main function is to detect that the driver is at the controls while the train is operating. An advance design on what in the past was known as a ‘deadman’ system which refers to its purpose of braking the train if the driver became incapacitated or deceased. The standard for train (driver) safety systems defines an operator enable system as ‘a device that applies emergency brakes and disables traction power if a continuous control input required of the driver or operator is interrupted or not detected’.<sup>38</sup>

The Special Commission of Inquiry’s report into the Waterfall train derailment in 2003 discussed the deadman system. It found that: ‘in New South Wales, prior to the Tangara, there were no electric trains with a deadman foot pedal device. The then-existing electric train fleet had a single deadman feature on the power / brake handle that required downward pressure to be applied to maintain it in the set position.’<sup>39</sup> The current operator enable systems have advanced to a more sophisticated level than those used in the past and are designed to minimise circumventions.

The functional and performance requirements for operator enable systems installed on passenger trains in New South Wales are outlined in an ASA specification.<sup>40</sup> These specifications require that while a driver is driving a train, in either the sitting or standing position, the automatic brake application be suppressed by an operator enable pedal (OEP) operated in the normal operating range (or in vigilance acknowledge range), or by the rotation of an operator enable handle (OEH) (Figure 11).

---

<sup>38</sup> Asset Standards Authority *Train (Driver) Safety System, T HR RS 00840 ST, v2.0*, issued 4 November 2016. p.9.

<sup>39</sup> McInerney, PA. (2004) *Interim Report of the Special Commission of Inquiry’s report into the Waterfall*

<sup>40</sup> *Passenger Rolling Stock Driver Safety Systems*, Op. Cit. p.10.



**Figure 11: Driver safety systems**



*This figure shows the location of the driver safety systems on A42. The insert shows the power / brake handle and the twist grip which acts as part of the operator enable system.*  
 Source: ATSB

The operator enable system on Waratah trains consists of both an OEP and an OEH. The presence of both handle and pedal allows drivers to alternate between arm and leg muscle groups and give drivers the option to stand while driving.

The OEP is also used as the driver's footrest. The height of the pedal and surround can be raised or lowered by the driver. The angle of the surround is approximately 28° from horizontal which slopes towards the driver. The pedal has a normal operating position range of approximately 26° to 30° from horizontal.

In order to enable traction and release the brakes, either the OEP must be depressed or the OEH power / brake handle twist grip turned approximately 20° clockwise. The power / brake handle needs to be in the forward or reverse position for this to operate. To operate the OEH a force of 8 N ( $\pm 10$  N) is required. The force specification is such that the force required to be applied shall not cause injury or discomfort taking into account the shift length the drivers are required to operate.

There are three main stages to the OEP (Figure 12):

- Released range: here the pedal is in the fully released position where no force is applied.
- Normal operating range: the driver depresses the pedal into this range which activates the system and suppresses the automatic brake application. The force required to depress the pedal from the released range to the normal operating range is 50 N ( $\pm 10$  N). In order to hold the pedal in-line with the surround a force of less than 80 N is required. (This equates to a mass of approximately 8 kg).
- Vigilance acknowledgement range: when the driver further depresses the pedal it links to the vigilance control system, vigilance is acknowledged and the automatic brake application suppression is maintained. The force required to depress the pedal from the normal to vigilance acknowledge range is 120 N ( $\pm 10$  N). If the pedal is held in this range for more than three seconds, a second stage vigilance activation will occur and give an

audible warning. This mean the driver has 5 seconds to acknowledge using the vigilance button before an automatic brake application occurs.

After East Richmond, the system did not detect a change in the driver’s application of the operator enable system. It is likely that once the driver applied the power/brake control handle to brake (39%) at 0951:06.1, he did not need to use the OEH and simply maintained pressure on the OEP. About 30 m before the train impacted the buffer stop, at 0951:28.5, the OEP indicated an increased force being applied to the pedal; this remained high until after the collision. It is likely at this point that as the driver of A42 realised the train was about to collide with the buffer stop, he braced himself for impact by increasing his leg force on the OEP.

**Figure 12: Operator enable pedal operating ranges**

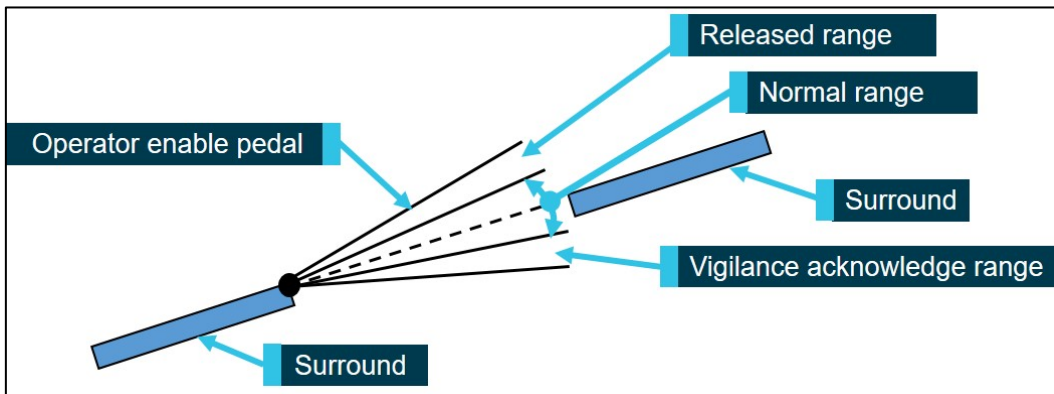

*This figure shows the side view of the main operating positions of the operator enable pedal on A42. Source: ASA Passenger rolling stock driver safety system, modified by ATSB*

Research has shown that it is possible to be in a semi-conscious state and still perform simple tasks. An investigation into a rail collision between two coal trains at Beresfield, New South Wales in 1997, discussed the issue of a driver not responding to signals. The report highlighted research into Automatic Behaviour Syndrome. The discussion of this syndrome may also explain the actions of the driver at Richmond.

‘There are various forms of sleep on the sleep-wakefulness continuum, ranging from a state of drowsiness (stage 1 sleep) as a person transitions from wakefulness to sleep, through to deep sleep. Generally, a person woken from stage 1 sleep will not be aware that they have been asleep. Stage 1 sleep can occur as ‘microsleeps’, or may involve longer episodes of lowered alertness, referred to as Automatic Behaviour Syndrome (ABS). The Transportation Safety Board of Canada defines Automatic Behaviour Syndrome as:

‘A state of fatigue in which we are essentially sleeping with our eyes open. While able to perform simple or familiar tasks, we are unable to respond quickly to more critical tasks and situations. In sleep lab studies, participants experiencing ABS show brain waves characteristic of sleep’.

The potential for vehicle drivers to ‘sleep with the eyes open’ was referred to as long ago as 1929 (Miles W. Scientific American June 1929, pp. 489-492). Recent scientific studies have confirmed that fatigued drivers can continue to drive while being asleep with the eyes open (Horne and Reyner 1998). In a US study, truck drivers were monitored for signs of sleep while driving normal deliveries on US public roads. Electroencephalogram (EEG) readings indicated that some drivers were continuing to drive while in stage 1 sleep for periods of up to 20 seconds (Mittler 1998).’<sup>41</sup>

Tests conducted following the incident confirmed that A42’s operator enable system, both the OEP and OEH, was functioning. The driver continued to operate the operator enable system

<sup>41</sup> New South Wales Department of Transport. *Independent Inquiry Report, Coal Train Collision, Beresfield, NSW, 23 October 1997*. P.22.

possibly due to automatic behaviour where he was still able to maintain with the required force on the OEP in the normal operating range.

### **Train stop systems**

A train stop system involves a trip cock on the vehicle and a trip arm located trackside which, when engaged, directly initiates an emergency brake application (Figure 13).<sup>42</sup> In NSW, train stop systems are fitted to multiple-unit passenger trains operating on the electrified lines.

**Figure 13: Signal train stop system**



This figure shows the trip arm next to signal RD5 at Richmond (left) and the trip cock on A42 (right).  
Source: ATSB

There are three main categories of train stops:

- Fixed train stops: at terminal platforms these operate as a permanent upright lever arm which trigger the emergency brake when struck by a train's trip cock.
- Signal train stops: located adjacent to a signal, the lever arm elevates when the signal is at stop and returns horizontal when the signal clears.
- Intermediate train stops: located at a determined distance from a known location where a reduction of speed is required. A speed detection device controls the lever arm so that if the train speed is not reduced to the required level before reaching a predetermined point, the lever arm remains raised.

The ASA standard for train (driver) safety systems defines the purpose of train stops and trip gear: 'to intervene and stop a train or vehicle fitted with trip gear if it fails to stop for a signal at stop (red signal aspect). When the train stop arm engages the trip cock, the associated valve directly vents the train or vehicle brake pipe to atmosphere, initiating the removal of (a cut in) traction power and an automatic (emergency) brake application on all vehicles within the train. The train stop is used

<sup>42</sup> Rail Industry Safety and Standards Board (RISSB) (2010) *Glossary of Rail Terminology*. p.256.



at signals in conjunction with a red signal aspect and in areas where train speed is required to be externally controlled.’<sup>43</sup>

The operating standard for rolling stock states that multiple unit passenger trains operating within the Sydney metropolitan rail network shall be fitted with trip gear equipment.<sup>44</sup> All Sydney Trains passenger trains are fitted with trip gear at the front of the train.

In 2005, an external engineering consultancy was commissioned by RailCorp<sup>45</sup> to investigate and review overrun protection in the Sydney greater metropolitan area. RailCorp had identified 35 terminal track locations that could involve passenger trains in overrun incidents.

The 2005 report investigated and reviewed what overrun protection was in place and what options were available, and made recommendations to reduce risk. Richmond Station was one of these locations and, amongst other recommendations; the report recommended that intermediate train stops be installed at Richmond Platform 2. The report stated:

‘the worst case scenario at this platform would be the brakes failing and the train impacting the buffer stop at a probable worst case speed of 40 km/h, ...the current buffer would be overloaded and not survive impact.’

The report stated that one of the options to reduce risk at Richmond Platform 2 was ‘to install two intermediate train stops, rated at 15 km/h and 8 km/h.’<sup>46</sup> The completed report was provided to RailCorp and there is documentation which suggests that a risk workshop was held by RailCorp on 8 April 2005. There is no record of any actions being undertaken as a result of this workshop and it appears that the recommendations pertaining to Richmond were not acted upon.

In 2008, the same external engineering consultancy was commissioned by RailCorp to review the previous 2005 report and to assess the performance of overrun protection specifically at two stations: Richmond and Carlingford. The review found that a risk assessment model was applied to each station and ‘Richmond Platform 2 was rated as highest risk of injury and fatality due to train overrun’.<sup>47</sup> The report stated: ‘the worst case scenario at this platform would be the brakes failing and the train impacting the buffer stop at a probable worst case speed of 25 km/h, the current advertised approach speed. The current buffer would be overloaded and not survive impact.’ The report recommended that one of the options to reduce risk at Richmond Platform 2 was ‘to install two intermediate train stops, rated at 25 km/h and 15 km/h.’<sup>48</sup>

Sydney Trains provided these reports to this investigation. It appears that the details and safety recommendations from these reports were not included as part of Sydney Trains’ program for asset improvement. The actions to improve the risk profile by installing intermediate train stops at Richmond and Carlingford were not implemented before the collision.

Following the collision, Sydney Trains has reviewed the signal system at Richmond and implemented a signal control upgrade utilising two intermediate train stops and one fixed train stop to reduce the risk of a train overshooting the platform at Richmond Station. The installation occurred in April 2019, 15 months after the collision. This train stop would trigger a brake application if a train speed exceeds 25 km/h approaching the train stop.

On the day of the collision, at signal RD5, the approximate speed of A42 was 47 km/h. The shortcoming of an intermediate train stop is that it is still possible for a driver to increase speed once past the signal and also for the driver to become incapacitated past the train stop. Another

<sup>43</sup> Asset Standards Authority. *Train (Driver) Safety System, T HR RS 00840 ST, v2.0*, issued 4 November 2016. p.20.

<sup>44</sup> Asset Standards Authority Standard RSU 100 Series – *Minimum Operating Standards for Rolling Stock – General Interface Requirements 7.5.1*. p.66.

<sup>45</sup> RailCorp was the precursor organisation to Sydney Trains. Sydney Trains, also a NSW Government agency, started operating all suburban services in the Sydney metropolitan area from 1 July 2013.

<sup>46</sup> Sinclair Knight Merz (SKM) (2005) *Report on existing overrun protection at terminal tracks and proposals for upgrades*. p.32.

<sup>47</sup> Sinclair Knight Merz (SKM) (2008) *Buffer stops at Richmond and Carlingford*.p.4.

<sup>48</sup> Op. Cit. SKM report (2005). p.32.



system to control train speed, Automatic Train Protection, was planned to be implemented at the time of the Richmond collision.

**Automatic train protection system**

The Automatic Train Protection system (ATP) is a system that monitors the train’s speed against the trackside target speed. It alerts the driver of a braking requirement and automatically applies train brakes if its speed significantly exceeds line speed parameters. It consists of on-train and trackside equipment that act independently of drivers and signallers (Figure 14).

**Figure 14: Automatic Train Protection**

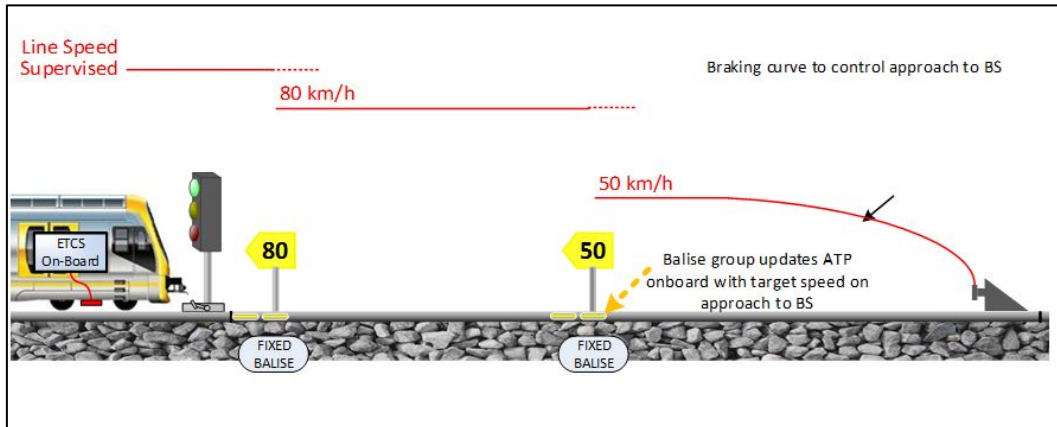

This figure shows the functionality of the ATP system as the train approaches a buffer stop. Source: Transport for NSW

The implementation of ATP on the Sydney passenger rail network was one of the recommendations of the Special Commission of Inquiry’s report into the Waterfall train derailment in 2003. It recommended that: ‘RailCorp should progressively implement, within a reasonable time, level 2 automatic train protection. Level 2 ATP systems provide automatic enforcement (slowing/braking) of authority (speed/location) if a train is behaving in an unauthorised way.’<sup>49</sup>

The ATP project was first commenced by RailCorp in 2006 and was progressed until June 2012 when responsibility for the delivery of the project was transferred to TfNSW.

All recommendations from the Special Commission of Inquiry were tracked, initially by the NSW rail regulator, the Independent Transport Safety Regulator (ITSR), and since 10 March 2017, the national rail regulator, the Office of National Rail Safety Regulator (ONRSR). ONRSR reports publicly on open recommendations.

The report into the implementation of the NSW government’s response, published in April 2018, provided a comprehensive update of the progress of the installation of ATP (Table 2). It stated: ‘With the exception of the Tangara fleet, the forecast completion date for the delivery of TfNSW’s ATP project is December 2020 and full deployment is expected in May 2021 with the anticipated completion of the Tangara fleet upgrade’.<sup>50</sup>

<sup>49</sup> McInerney, PA. (2004) *Interim Report of the Special Commission of Inquiry’s report into the Waterfall rail accident*. p.32.

<sup>50</sup> Office of the National Rail Safety Regulator (2018) *Implementation of the NSW Government’s response to the Final Report of the Special Commission of Inquiry’s report into the Waterfall rail accident*. p.9.

**Table 2: Forecast completion dates for Automatic Train Protection**

<b>ETCS Level 2 Pilot Trial</b>		
<b>Key Milestones</b>	<b>Scheduled Installation Completion Date</b>	<b>Forecast Installation Completion Date (As at 31 March 2018)</b>
Level 2 Pilot Trial	September 2015	Completed
<b>Rollingstock ATP Fitment</b>		
<b>Key Milestones</b>	<b>Scheduled Installation Completion Date</b>	<b>Forecast Installation Completion Date (As at 31 March 2018)</b>
OSCAR (H sets)	June 2017	Completed*
V sets	December 2017	July 2019
Tangara (T sets)	June 2018	May 2021
Millennium (M sets)	July 2018	August 2019
C sets	September 2018	June 2019
K sets	September 2018	May 2020
Waratah (A sets)	December 2019	January 2020
<b>Trackside ATP Fitment</b>		
<b>Key Milestones</b>	<b>Scheduled Installation Completion Date</b>	<b>Forecast Installation Completion Date (As at 31 March 2018)</b>
ATP Early Deployment Scheme	November 2018	November 2018
ATP First Revenue Service	March 2019	March 2019
Project Completion – 100% ATP (Areas 1 to 9)	December 2019	March 2020
<b>ATP Testing</b>		
System Integration Testing	December 2017	July 2018
<b>ATP Full Deployment</b>		
Full deployment	December 2019	May 2021

Source: ONRSR

The installation of ATP on Waratah (A-sets), if installed at the time of the buffer stop collision, would likely have prevented the train colliding with the buffer stop at Richmond. The system would have detected that the train was approaching the buffer stop at unauthorised speed and applied the train's brakes automatically.

## In-cab audio and video recording

The cause of the driver being unresponsive at the controls for a period of time leading up to the collision may have been resolved if the driver's cab was fitted with an inward-facing camera recording the driver's actions. The video may have shown what the driver was doing and his state of consciousness leading up to the collision. The presence of a camera would not have prevented the collision, but would have assisted in the post-incident analysis. An audio recording, synchronised with the camera, may have provided additional information about the driver's actions, and possible alarms or sounds inside the cab. Having audio and video recording allows investigators to eliminate, early in the investigation, potential contributory factors such as mobile phone-use or other distraction-type events.

Waratah trains are fitted with 64 internal and 34 external cameras (including 16 cameras on each side plus one camera at each end). Only one of the end cameras faces forward (at any time) with the other rearward. They both record. The guard cannot select to view the images from the end of

set cameras. At approximately 250 m prior to the station, the guard's surveillance screens automatically switch to display external side camera views to display entry into the platform. The forward-facing cameras have proved especially useful for investigators in determining what has happened during events such as: derailments, SPADs, level crossing incidents and collisions. Forward-facing video of the buffer stop collision was available and proved useful in analysing the event.

There is no current requirement for rail operators to fit inward-facing cameras or voice-recording devices in driver's cabs. In NSW, there is rail safety compliance code for data loggers which sets out minimum requirements for data loggers fitted in rolling stock.<sup>51</sup> While it does not specify inward-facing cameras, it does mention that operators may consider cab-based forward-looking video recording. Many rail operators have already fitted, of their own volition, forward-looking video cameras.

A precedent for in-cab recording of drivers exists in the NSW bus transport environment where inward-facing cameras and audio-recording microphones are installed to record driver's actions. Metropolitan bus operators are required under the Passenger Transport Regulation 2017 to ensure each bus in the fleet is fitted with an approved security camera system.<sup>52</sup> The requirement is that, along with other cameras, a camera is installed in the driver's cabin and is directed towards the driver, including one microphone in the vicinity of the driver. These requirements are specified under Transport for NSW bus procurement contracts. Protections against use for unauthorised purposes exist in the regulation. The use of these recordings has proved invaluable in determining the cause of many accidents, particularly driver incapacitation incidents, and has played an important role in improving operational safety.

In the USA, the NTSB have long advocated the use of recording devices inside locomotive cabs as an aid in accident investigations and for use by transportation management in efficiency testing and performance monitoring programs. Their initial recommendation for voice recorders came as a result of their investigation of a 1996 accident between a Maryland Rail Commuter train and an Amtrak train near Silver Spring Maryland. There were 11 fatalities including three operating crew.<sup>53</sup>

The NTSB have reiterated and enhanced this recommendation in numerous accident investigations since. In 2010, the NTSB, in a safety recommendation report, made a recommendation to the Federal Railroad Administration (FRA) to require the installation, in all controlling locomotive cabs and cab car operating compartments, of inward- and outward-facing audio and video recorders capable of providing recordings to verify train crew actions and train operating conditions.<sup>54</sup> In 2015, US federal legislation<sup>55</sup>, required inward- and outward-facing cameras on all passenger locomotives (when leading). According to the FRA, most larger freight operations and a few passenger operations have already installed inward-facing cameras in anticipation of regulation.

In 2013, the Transportation Safety Board of Canada (TSB) recommended 'The Department of Transport require all controlling locomotives in main line operations be equipped with in-cab video.'<sup>56</sup> Since that time, the TSB have continued collaborative efforts to move the issue forward, and in May 2017, legislation was introduced in the Canadian House of Commons to mandate locomotive voice and video recording (LVVR) in locomotive cabs. Transport Canada has been conducting pre-consultation and drafting of its new regulations relating to the introduction of LVVR.

---

<sup>51</sup> Office of the National Rail Safety Regulator (2011). *Rail Safety Compliance Code – Data Loggers*. Section 4.

<sup>52</sup> NSW Passenger Transport Regulation 2017 cl. 82.

<sup>53</sup> US National Transportation Safety Board (1997) Safety Recommendation RAR-97/02 from Collision and Derailment of Maryland Rail Commuter MARC Train 286 and National Railroad Passenger Corporation Amtrak Train 29 Near Silver Spring, Maryland, on February 16, 1996.

<sup>54</sup> US National Transportation Safety Board (2010) NTSB Safety Recommendation R-10-001.

<sup>55</sup> Fixing America's Surface Transportation Act – Public Law 114<sup>th</sup> Congress Public Law 94, 2015, Sec. 11411.

<sup>56</sup> Transportation Safety Board of Canada (2013) TSB Recommendation R13-02.

The following table shows recent Australian rail investigations where in-cab audio and video recording of the driver, if available, would likely have assisted in determining the actions of the train crew and would likely have provided an accurate record of the events in the driver's cab (Table 3).

**Table 3: Australian rail incidents where in-cab audio and video recording may have assisted the investigation**

Location	Date	Title and brief summary
Hurlstone Park, NSW	30 Jan 2013	Multiple SPAD by freight train 9837 – train crew, both possibly asleep, passed two signals at stop while track workers were on the track ahead.
Kilbride, NSW	22 May 2014	Near hit with derailed passengers on track at Kilbride - the crew of V938 derailed passengers onto the track without having arranged the required train protection.
Mt Druitt, NSW	12 Mar 2015	Wrong running direction involving passenger train 165-S – a driver drove an empty cars passenger train in the wrong direction for 761 m.
Hornsby, NSW	17 Dec 2015	SPAD and derailment of empty Tangara service 109D – driver was distracted by another driver in the cab and passed two signals.
Muswellbrook, NSW	2 Dec 2016	Disabled Xplorer passenger service NP23. Driver reacted to fire alarm from auxiliary engine and over 200 passengers stranded on board train.
Unanderra, NSW	22 Apr 2017	Runaway of grain train 8960 – a fully loaded grain train runaway down Illawarra mountain reaching a speed of 107 km/h.
Petrie, Qld	12 Oct 2017	SPAD by train 2552 – a driver, driving an empty suburban passenger train, passed a signal at stop and did not recall acknowledging the onboard Automatic Warning System.
Bowen Hills, Qld	10 Jan 2018	Signal ME45 passed at danger resulting in a near-miss between suburban passenger trains TP43 and TR50. The driver was unaware of the SPAD occurrence and continued to operate the train as if the signal was not displaying a stop indication.
Wagga Wagga, NSW	1 Mar 2019	Pacific National grain train 5KC3 passed a series of signals at danger. The train came to a halt approximately 3 km from train 5BM9 which was travelling in the down direction on the same line.

In many investigations, having in-cab audio and video recordings from the driver's cab would have provided unequivocal primary evidence to assist in determining the contributory factors to an incident.

It would be beneficial if the relevant Australian agencies would commence the process of consultation with key stakeholders regarding a requirement for Australian rail operators to install in-cab audio and video recorders in driver's compartments.

### Buffer stop issues

Buffer stops are infrastructure items at the end of rail tracks or sidings which are used to prevent rolling stock from running off the end of the track or colliding with adjacent structures. In the event of a train colliding with the buffer stop, another main function is to reduce the impact forces transmitted through the rolling stock in order to minimise injury to train crew and passengers and to minimise damage to the rolling stock itself.

Energy-absorbing and fixed buffer stops are the two most common types used by railways in Australia. The purpose of an energy-absorbing buffer stop is to progressively transform a train's energy into heat through friction elements that move together with the buffer stop frame along the track or through the displacement of hydraulic rams or springs. Fixed buffer stops generally consist of a frame or block rigidly fixed to the rails or in the ground. A rigid buffer stop has a limited ability to dissipate a train's kinetic energy and is generally only effective in low-speed collisions (10 km/h or below).



The ASA buffer stop standard specifies that the energy-absorbing buffer stops may be of the following types:

- Friction – used where there is sufficient distance for the friction shoes to slide along the rails (Figure 15)
- Hydraulic – dissipate energy where hydraulic rams slow the train (Figure 16)
- Combination of friction and hydraulic – initial impact taken by the hydraulic rams with residual energy transferred to the buffer frame (Figure 17).<sup>57</sup>

**Figure 15: Friction buffer stop**



*This shows an energy- absorbing friction buffer stop. It has sliding friction shoes, anti-climbers and a coupler-compatible arrangement at the front.*

Source: TfNSW with annotations by ATSB

<sup>57</sup> Transport for New South Wales Standard *Buffer Stops* T HR TR 25000ST, Version 1.0, Issued: 10 July 2017.p.11.

**Figure 16: Hydraulic buffer stop**



*This figure shows an energy-absorbing hydraulic buffer stop. It has hydraulic rams, a buffer beam and a coupler-compatible arrangement at the front.*  
Source: TfNSW with annotations by ATSB

**Figure 17: Combination hydraulic and friction buffer stop**



*This figure shows an energy-absorbing combination of hydraulic and friction buffer stop. It has friction shoes designed to stop or slow the train upon impact. The front of the buffer stop has a hydraulic arm with a rubber face coupling arrangement.*  
Source: TfNSW with annotations by ATSB

The buffer stop at the end of Platform 2 at Richmond Station (the Richmond buffer stop) did not absorb the energy of the collision with A42 as was expected. The reason is that the hydro-

pneumatic rams on the buffer stop were not aligned with the crash energy management system at the front of the Waratah train. Instead of the rams aligning with a solid surface and absorbing energy, they penetrated the cavity on either side of the automatic coupler at the front of the train and were bent downward and inward. The buffer was designed for rolling stock operating at the time of installation such as the K-set, introduced into service 1981-85. These were not operating on the Richmond line at the time of the accident.

As a result of these energy-absorbing rams not performing as intended, the force of the collision was instead transferred to the crash energy-management system of the train and the concrete body of the buffer stop. The front of the coupler collided with the vertical face of the reinforced concrete end stop of the buffer stop. This activated the crash energy management system associated with the coupler which features gas-filled chambers and crash tubes. It should be emphasised that, ideally, the rams on the buffer stop act in conjunction with the train's crash energy management system to absorb impact energy (Figure 18).

**Figure 18: Richmond buffer stop and front CEMS of A42**

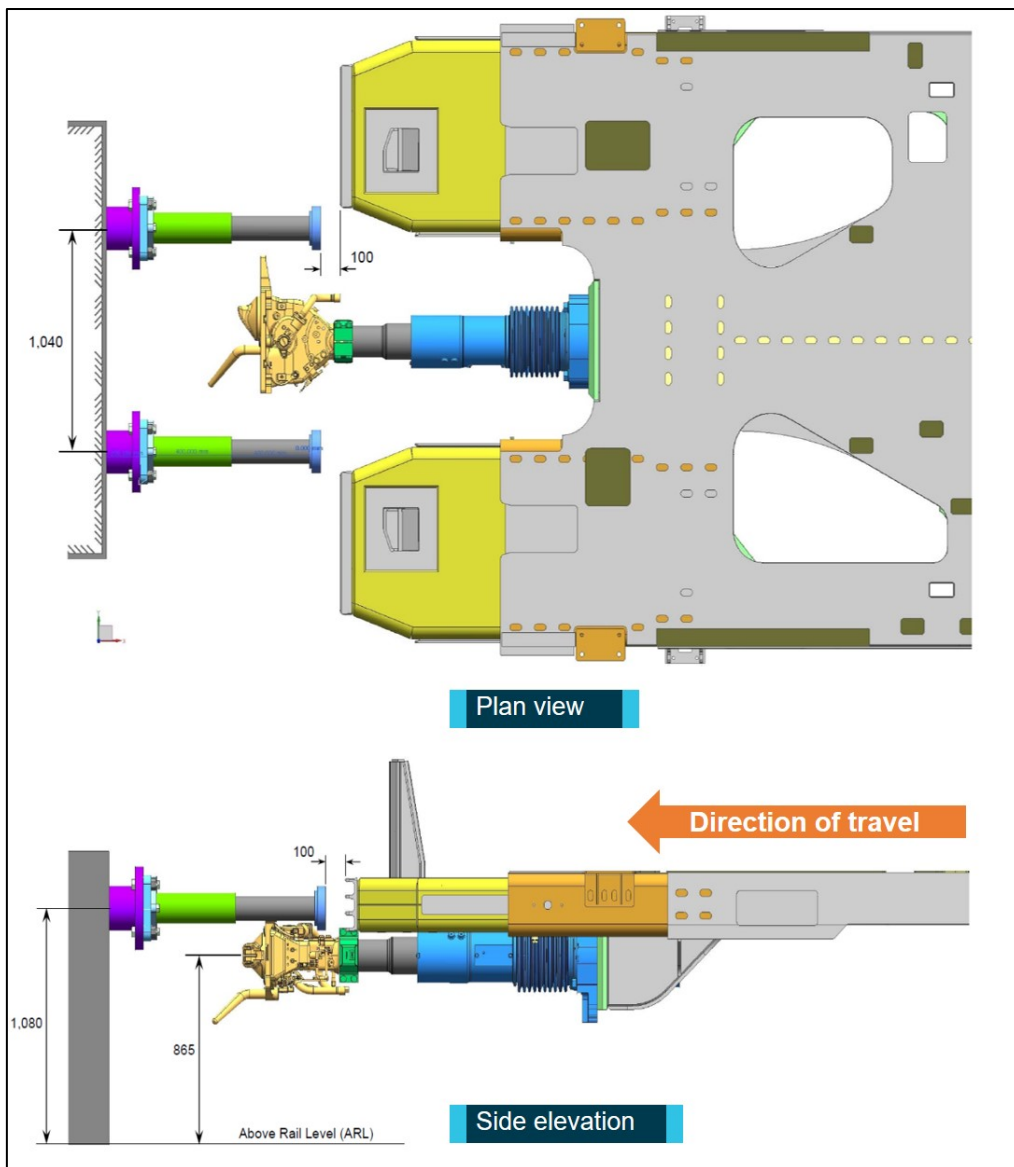

*This figure shows the plan view and side view of the Richmond buffer stop and the front of train CEMS of A42 just before contact. Source: Downer with annotations by ATSB*

The buffer stop at Richmond has an energy capacity of 896 kJ which represents approximately 8% of the total collision energy associated with an impact speed of 26 km/h. This type of buffer is suited for low-speed collisions of approximately 10 km/h.



The latest buffer stops installed on the Sydney metropolitan rail network are compliant with the current ASA buffer stop standard. The current ASA buffer stop standard states that buffer stops should be designed to suit the range of couplers on the rolling stock operating on that track.<sup>58</sup> The energy-absorbing aspect of the Richmond buffer stop was not compatible with this Waratah train which operated regularly on the Richmond line and had done so for more than 5 years. The Richmond buffer stop was not compatible with most other Sydney Trains rolling stock.

As discussed earlier, an external engineering consultancy was commissioned by RailCorp in 2005 and 2008 to review the effectiveness of overrun protection.

The 2005 report investigated and reviewed what overrun protection was in place in the Sydney greater metropolitan area. It made recommendations to reduce the risk of overrun in 35 locations. Richmond was one of these locations and the report recommended the installation of a friction-type buffer stop, as well as extending the platform length by 1 m.

The 2008 report focussed only on the two identified high-risk locations, Richmond and Carlingford. It reported that the existing buffer arrangements at Richmond would not survive an impact of a 500 t train with an approach speed of 26 km/h or above.<sup>59</sup> This assessment was incorrect, as was demonstrated in the collision with the buffer stop on 22 January 2018. The collision showed that in fact the buffer stop would stop a 500 t train at 26 km/h (despite the energy-absorbing arms not performing as designed). The train was successfully stopped, and then recoiled approximately 3 m. The buffer stop survived largely intact and was moved approximately 12 mm backward.

The 2008 report recommended a number of improved buffer stop options for Richmond platform 2. Like the 2005 report, one option recommended was the installation of a friction-type buffer stop and the extension of the platform by 1 m. Another option recommended was the installation of a combination hydraulic and friction buffer stop. As stated previously, there was no evidence provided to indicate that RailCorp acted upon any of the recommendations regarding overrun protection at Richmond or Carlingford stations, nor could any reasons be provided for the inaction.

Neither the 2005 or the 2008 report mentioned the potential ineffectiveness of the hydro-pneumatic rams on the Richmond buffer stop. Also, the reports did not discuss the compatibility of the buffer stops with the crash energy management systems on the newer rolling stock. At the time the reports were written, both the T-set (Tangara) and M-set (Millennium) trains, which are fitted with the Scharfenberg coupler and a form of crash energy management system, were in operation.

### ***Design of the replacement buffer stop at Richmond***

Following the collision, Sydney Trains assessed the damage to the buffer stop at Richmond Platform 2 and conducted an internal investigation. They also convened meetings with internal and external stakeholders, including the ASA and the original engineering manufacturer of the hydraulic rams. After considering a range of options, Sydney Trains decided to demolish the existing Richmond buffer stop and replace it with a redesigned buffer stop that is compliant with the ASA buffer stop standard (Figures 19 and 20). This design may be used for replacement of other buffer stops on similarly highly length-constrained passenger terminating site on the Sydney metropolitan rail network.

Due to the proximity of a major road, Market St, situated behind Richmond Station, it was determined that it was not feasible to extend the length of the track past the platform. This restricted the type of energy-absorbing buffer stop that could be installed at the western end of Richmond Platforms 1 and 2 to a hydraulic buffer stop. The extension of the platform to the east was also problematic due to the track and infrastructure configuration. This means there was not

---

<sup>58</sup> Transport for New South Wales Standard *Buffer Stops* T HR TR 25000ST, Version 1.0, Issued: 10 July 2017. Clause 13.6.

<sup>59</sup> SKM report (2008) Op.Cit. p.28.



the requisite activation length<sup>60</sup> for a friction buffer stop or a combination hydraulic and friction buffer stop at Richmond Platforms 1 and 2.

The replacement buffer stop design includes a buffer beam design where the dimensions are adjusted to suit the rolling stock operating in that area. The design complies with the standard which states that the buffer face should be designed for the automatic coupler (Sharfenberg type 10) but should also be capable of stopping a train fitted with an automatic (AAR 10A) interlocking coupler. The buffers also incorporate anti-climber contact areas to reduce the risk of a train overriding the buffer stop upon collision at a speed above the design speed.

**Figure 19: Redesigned buffer stop**

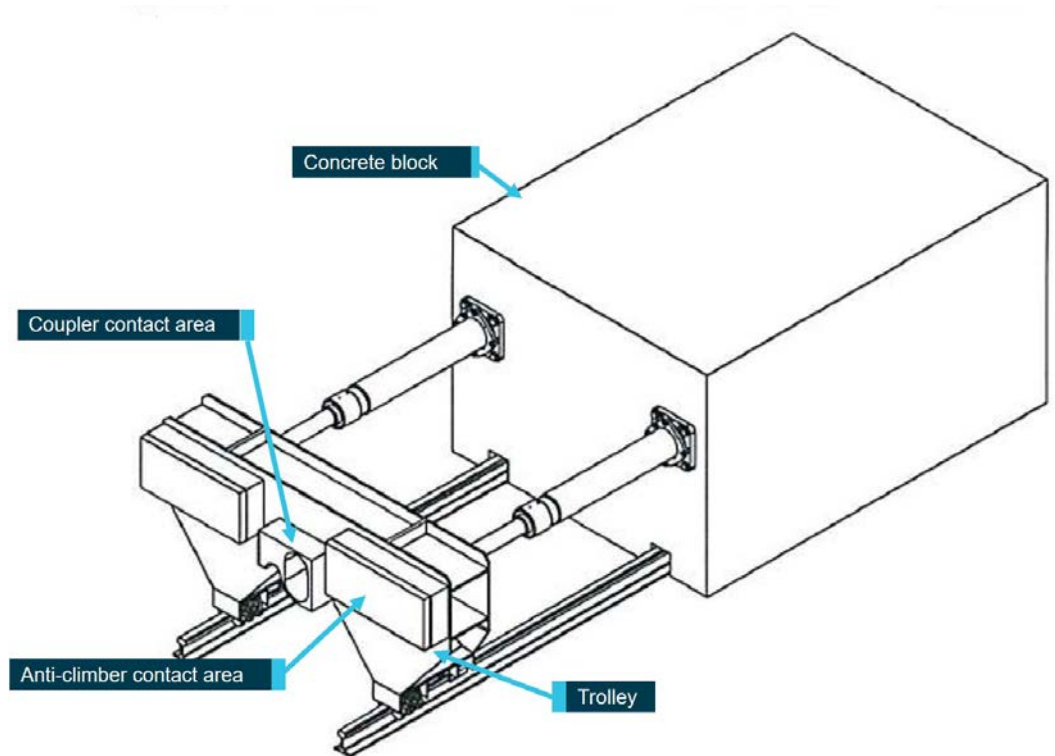

*This diagram shows the design for an energy-absorbing hydraulic buffer stop that was the basis for the replacement buffer stop at Richmond.*  
 Source: Sydney Trains with annotations by ATSB

<sup>60</sup> Transport for New South Wales Standard *Buffer Stops* T HR TR 25000ST, Version 1.0, Issued: 10 July 2017. p.25.

**Figure 20: Redesigned buffer stop for Waratah and Millennium trains**

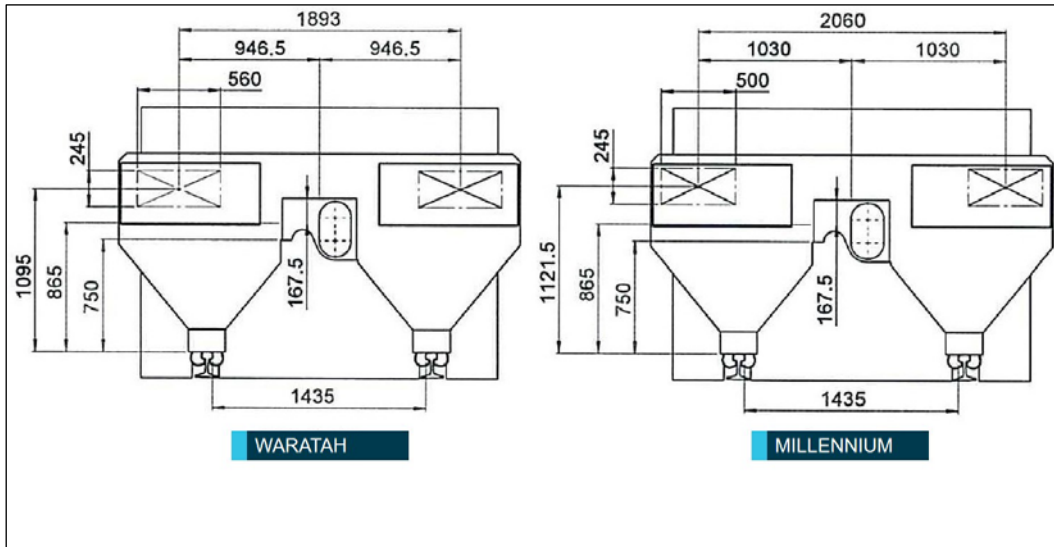

*This elevation drawing shows the differences in design of the front buffer beam for the Waratah and Millennium trains.  
Source: Sydney Trains*

**Risk assessment of buffer stops**

Sydney Trains indicated that there were a total of 167 buffers stops in the Sydney metropolitan network. According to a network-wide review of buffer stops undertaken by Sydney Trains, following the incident, none of buffer stops, at the time of the collision, met the ASA buffer stop standard Specification ASA T HR TR 25000 ST V1.0, 10 July 2017. The majority of these are at the end of sidings and stabling yards where passengers would not be expected to be on board the service. For example, at Richmond, only two of the three buffer stops are at the end of a regular passenger line. The other line, the Up storage siding, has no platform for passenger access.

The most safety-critical buffer stops are positioned where approaching trains have passengers on board. These are typically at the end of a regular passenger line, examples of which are at Carlingford, Cronulla, Richmond and at Sydney Terminal (Central). An additional function of many of these buffer stops is that they prevent the train from running off the track and entering another environment.

The Carlingford buffer stop, when inspected in March 2019 (14 months after the Richmond collision), still had the standard Department of Railways NSW, Way and Works Branch, 1963-designed timber fixed buffer stop bolted to the track (Figure 21). Reviewing the effectiveness of this buffer stop, the 2008 report calculated that timber buffer stops are unable to resist a force of 1000 kN and would break away. The report stated that ‘the current fixed timber buffer stop would not be able to arrest any train effectively at any speed.’<sup>61</sup>

<sup>61</sup> SKM report (2008) Op.Cit. p.5.

**Figure 21: Fixed buffer stop at Carlingford station**

*This figure shows the buffer stop at the end of the line at Carlingford station on the Sydney rail network.*  
Source: ATSB

Following the collision, Sydney Trains conducted an end-of-line risk prioritisation of the safety-critical buffer stops on its network. The review rated 23 buffer stops with a category 1 level hazard rating and a further 15 with a ranking range from 2 to 5. The following four locations achieved a top prioritisation for mitigation measures to be put in place: Central Platform 9, Richmond Platform 2, Macarthur turn-back road, and Carlingford.

The buffer stops at Richmond Platforms 1 and 2 have been redesigned and are scheduled for replacement in 2020. The buffer stop at Richmond Up storage siding line will retain the old design buffer stop as this line is not used for passenger services.

Sydney Trains have notified this ATSB investigation that no planned upgrades to the Carlingford line will be undertaken. This line will be relinquished from Sydney Trains' control from the end of 2019. A proposed light rail service is planned to operate in this rail corridor.

## Crashworthiness and crash energy management

The aim of designing for crashworthiness is to mitigate the consequences of collisions in a controlled manner and to reduce the risk of injury to the occupants.<sup>62</sup> The British and European standard for crashworthiness requirements for railway vehicle bodies states that it is impractical to design for all possible crash scenarios. Therefore, the design collision scenarios chosen represent the most common collision situations and those that might result in most casualties.

These are:

- A front-end impact between two identical train units
- A front-end impact with a different type of rail vehicle
- Train unit front impact with a large road vehicle on a level crossing
- Train unit impact into low obstacle (e.g. car on a level crossing, animal, rubbish).

<sup>62</sup> British Standard BS EN 15227:2008 +A1:2010 – Railway applications - Crashworthiness requirements for railway vehicle bodies. p.5.

The general principles are:

- Reduce the risk of overriding
- Absorb collision energy in a controlled manner
- Maintain survival space and structural integrity of the occupied areas
- Limit the deceleration
- Reduce the risk of derailment.

The crashworthiness requirements for the Waratah were specified in a RailCorp specification,<sup>63</sup> and no dynamic modelling of buffer impact scenarios was conducted during the design phase of the Waratah contract.

T-sets (Tangara) introduced into service between 1988 -1995 have a lower level crash energy management systems (CEMS), incorporating anti-telescoping columns designed to withstand a static end load of 700 kN. CEMS is not present on earlier model rolling stock such as the S-sets, K-sets or C-sets.

A feature of newer Sydney Trains passenger rolling stock is the presence of a CEMS. This feature is present on M-sets (Millennium) and A-sets (Waratah), however, the newer A-sets can accommodate a significant increase in energy absorption capacity in CEMS over the M-Sets. Although not explicitly specified in any standard, the M-set was the first to use anti-climbers between carriages. The design energy absorption capacity on the leading car is 3.215 MJ at 50 km/h which exceeds the British Standard Railway Group requirement of 1 MJ.<sup>64</sup> The collision energy of the train at this impact was calculated as approximately 10 MJ.

The design of the A-set enhances the crashworthiness performance by limiting vertical and lateral movement and has crush zones at the end of each car. The crush zones of unoccupied areas are intended to collapse in a controlled progressive manner, which assists to keep the cars in-line. The A-set CEMS was not designed to interface with the buffer stop arrangement installed at Platform 2 Richmond Station.

An ASA standard exists for the structural integrity and crashworthiness of passenger rolling stock. This standard covers the minimum requirements that passenger rolling stock shall meet over its design life.<sup>65</sup> It adopts the requirements from national and international standards including European standard EN 15227: 2008.

The Australian Rail Industry Safety and Standards Board have developed an Australian Standard (AS 7521:2017) which includes a section on collision energy management. It states that the rolling stock collision energy management strategy shall be supplied by the rolling stock designer. This strategy shall include the design of the interior elements and how they integrate with the exterior crashworthiness.<sup>66</sup>

### ***Crashworthiness design for A-set***

In 2009, on behalf of Downer, a specialist consulting firm called Delta Rail undertook a theoretical review of the crashworthiness risk of the A-set fleet as part of the public-private partnership (PPP) acquisition process. The review was to compare the crashworthiness design of the train against a train built to UK Railway Group Standard GM/RT2100 Issue 3. It stated that the collision management system was optimised for collisions between similar trains and was supported by a range of modelling and simulation. It covered the risk for collision with a buffer stop and stated:

'In the event of a buffer stop collision, the train's energy management system will provide some degree of mitigation, however, the level of protection will depend on the effectiveness of the contact and engagement between the coupler, anti-climbers and the buffer stop, together with the energy

<sup>63</sup> RailCorp Rolling Stock PPP – Double Deck Trains Train Performance Specification v21, 22 December 2015.

<sup>64</sup> Downer Rail Engineering Report CN01- crashworthiness methodology, CER01484, 25 April 2009.p.6.

<sup>65</sup> TfNSW Standard T MU RS 01000 ST *Structural integrity and crashworthiness of passenger rolling stock*, 2017.

<sup>66</sup> Australian Standard AS 7521:2018 Interior crashworthiness.



absorbing properties of the buffer stop. Some buffer stop types have very little likelihood of utilising the energy absorption capacity of the coupler because the coupler head cannot be restrained laterally under longitudinal loading, or is too low to contact the buffer stop, or there is no contact face in the region of the coupler. If the coupler does slip laterally on the buffer stop face, there may be considerable damage to the vehicle in the coupler pocket area without corresponding benefit in terms of controlled energy absorption.

'However, the PPP train will be no different in this respect from a GM/RT2100-compliant train. The remaining cars in rear of the leading car will retain the benefit of the energy management system. In the UK, Railway Group Standards GC/RT5033 and GC/RC5633 recommend that if the rolling stock on a route is to be changed, there should be a review of buffer stops by the infrastructure owner, and a risk assessment methodology is provided. It is therefore recommended that closure of this risk should be formally transferred to Railcorp.<sup>167</sup>

This recommendation that the review of buffer stops be undertaken if the rolling stock on the route is changed was not completed by RailCorp.

The Waratah Train crashworthiness performance was verified with respect to the requirements specified in the Train Performance Specification. This included:

- Dynamic impact testing on the couplers (both automatic and semipermanent couplers)<sup>68</sup>
- Verification testing on car end structure, vertical end crash barriers columns and anti-climbers<sup>69</sup>
- Design mass estimation and centre of gravity locations<sup>70</sup>
- VAMPIRE<sup>71</sup> simulations of the static twist test<sup>72</sup>
- Finite element analysis of energy-absorbing crash boxes<sup>73</sup>
- Crashworthiness methodology.<sup>74</sup>

It should be noted that verification of the A-set crashworthiness capabilities is based upon numerical simulations in conjunction with physical testing of the energy absorption elements. There was no physical testing of the overall set. The crash simulations are mathematical studies of the expected behaviour of the rail vehicles' response in various collision scenarios under particular conditions, the actual performance of the train in a real world collision may differ.

### ***CEMS features on A-set***

As stated previously, the presence of a CEMS is a feature of the A-sets. The following are the key design elements of the A-set's crashworthiness methodology:

The couplers consist of couplers at the end of the terminal cars and semi-permanent couplers between cars on an 8-car set. The coupler system is a standard design and the coupler head is fitted with a Scharfenberg (Voith) 10 coupler. The couplers incorporate both regenerative and non-regenerative energy-absorbing devices in the form of a gas-hydraulic ram (for elastic deformation) and a deformation tube (for plastic deformation). The gas hydraulic ram absorbs energy at varying amounts depending on the speed of collision. It reduces deceleration and recoil and also delays the point of structural deformation. It is designed to absorb the energy of an 18km/h symmetric collision without activating the deformation tubes.

<sup>67</sup> Downer, PPP Trains crashworthiness risk review Delta Rail Report - Body crashworthiness risk assessment. 8 November 2011.p.14.

<sup>68</sup> Downer, Dynamic Crash Test, PAU817-012, 15 July 2010.

<sup>69</sup> Downer, Engineering test report, CTR00710-001, 5 November 2011.

<sup>70</sup> Downer, Rolling Stock PPP Sets – Mass Estimation, CEC00523, 8July 2010.

<sup>71</sup> VAMPIRE – a vehicle dynamics simulation program.

<sup>72</sup> Downer, Static Twist Test Simulation, CEC00594 – CN01, 23 April 2009.

<sup>73</sup> Downer, Engineering Report – FEA of energy absorbing crash boxes, 15 May 2009.

<sup>74</sup> Downer, Engineering Report crashworthiness methodology, CER01484 – CN01, 25 April 2009.

The deformation tubes, if activated, consist of a mandrel which is forced into a tube of a slightly smaller diameter. This interference fit means that the mandrel deforms the tube and increases the tube diameter as it passes along the tube. The plastic deformation dissipates energy from the collision. Each tube is designed to arrest the design force at specified locations along the train set. It also withstands vertical loading which may assist in prevention of overriding.

On the end-of-train couplers there is up to 250kJ elastic deformation energy and 700kJ of plastic deformation energy-absorption capacity. On the semi-permanent couplers there is up to 480kJ elastic deformation energy and 1350kJ of plastic deformation energy-absorption capacity.

Two crash boxes, one on each side of the car, are located at both ends of all cars of the train. The crash boxes use a sacrificial deformation zone of an aluminium honeycomb core with a piston and ram arrangement (Figure 22). This absorbs a higher speed collision energy at a constant force level.

**Figure 22: CEMS elements on leading end of A-set driving (or terminal) car**

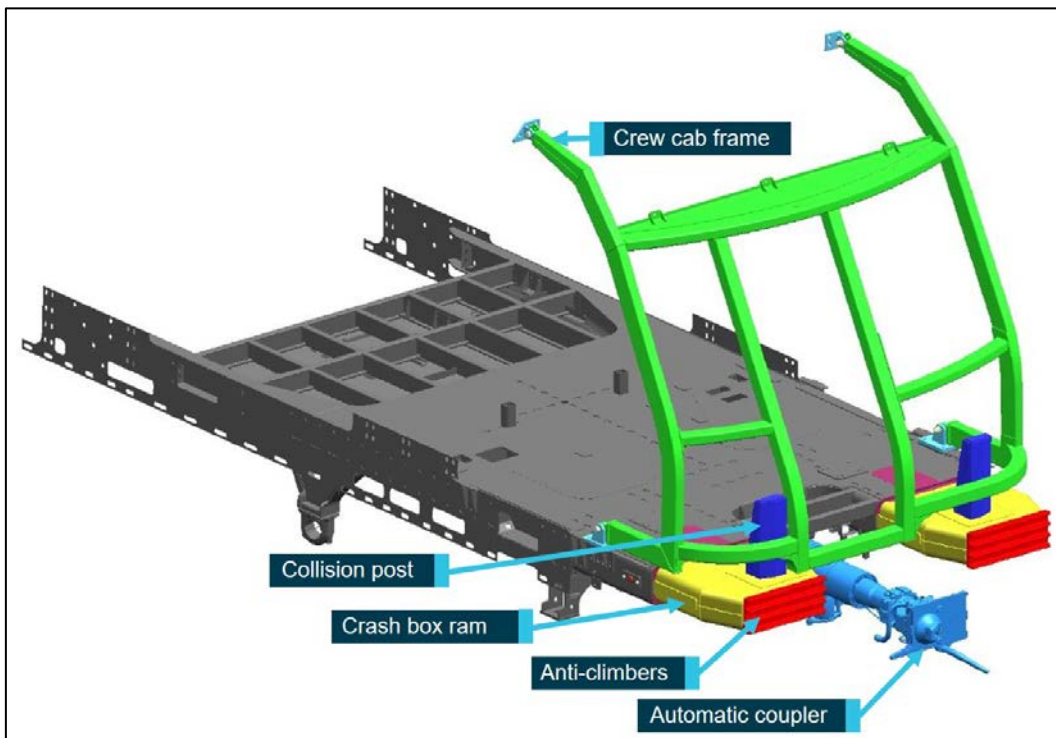

*This figure shows the parts of the crash energy management system on the driving car of an A-set.  
Source: Downer with annotations by ATSB*

Located on the front of the crash box rams are devices called anti-climbers (Figure 23). Anti-climbers consist of horizontal rib-like arrangements which are aligned to mesh with a coinciding anti-climber on the adjacent car (or buffer stop). The aim of the anti-climbers is to prevent vehicle overriding in the event of a collision impact and reduce the risk of telescoping of car bodies.

**Figure 23: CEMS parts on intercar end of A-set driving car**

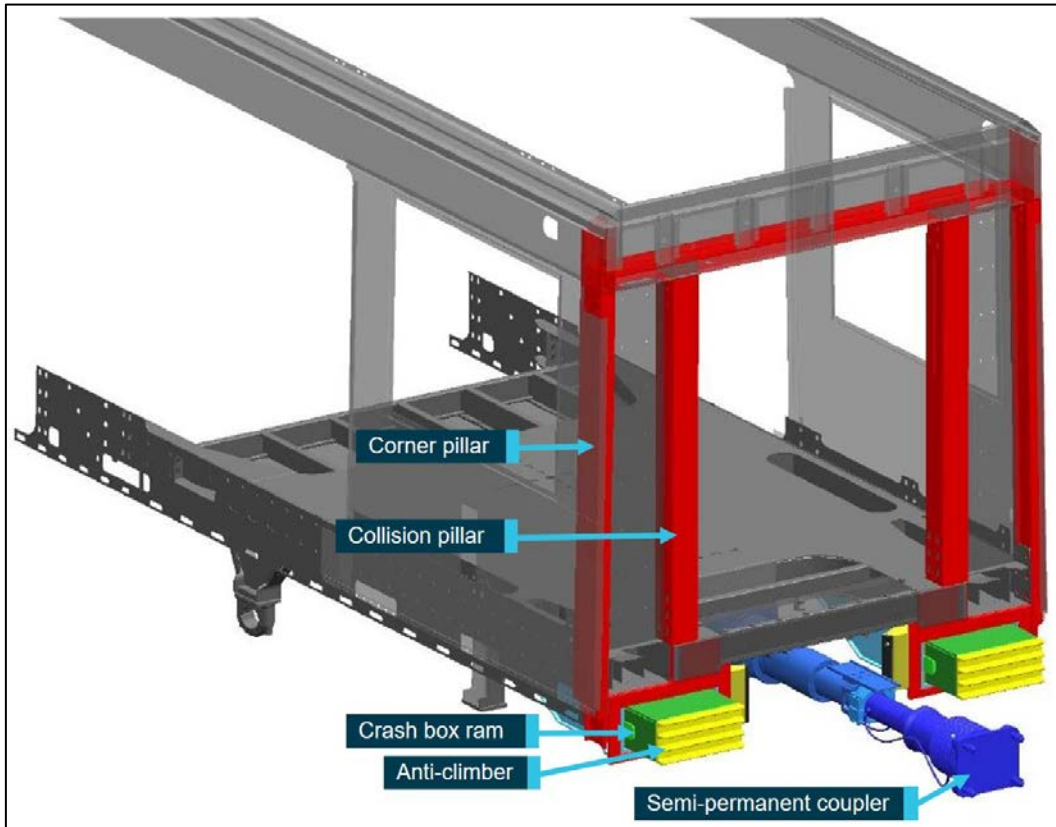

*This figure shows the parts of the crash energy management system on the intercar end of the driving car of an A-set.  
Source: Downer with annotations by ATSB*

Two collision pillars (posts) are also fitted to both ends of all cars (Figure 23). These provide additional strengthening to the end wall of the car to protect occupants. At the cab end of the train they terminate at window sill-height but otherwise extend from floor to ceiling height.

There are also a number of improvements to the A-set design that improved its strength and crashworthiness capability. These include:

- Improved car body-to-bogie attachment strength
- Increased car body strength
- High-impact resistant glass reinforced plastic (GRP) cab canopy
- Improved roll-over strength
- Improved interior design.

***Predicted behaviour of A-set during collision***

The behaviour of any train during a collision is dependent upon many factors including the track geometry (straight or curved), how the colliding cars interact, the coupling between cars, and the crush performance of the cars. If overriding of cars occurs, this can cause shearing or crushing of the lower car with the consequent serious risk to passengers. Another negative interaction caused by a collision can be lateral deflection in which the coupled cars form an accordion pattern when viewed from above. This escape from the track envelope creates additional risk, such as collision with a train on an adjacent track. An effective crash energy-management system will limit the vertical and lateral motions of the cars and lead to a controlled collapse of crush zones. Research has shown that this is effective in assisting to keep cars in line. A controlled deformation and collapse of designated sections also reduces the deceleration on passengers and crew.

The crash energy management system on an A-set is optimised to minimise force levels. The crash response sequence of the CEM is designed to be progressive in nature, with the initial

contactor deforming first, followed by the next structural component, and progressively along the train. Each section should exhibit sufficient resistance so that the plastic deformation of the previous section can dissipate energy.

It is anticipated that the leading car (Car 1) would be the first contact point of most collisions. In this case the following sequence should occur:

- At the front of Car 1, the coupler engages, pushing back the gas-hydraulic ram for a stroke of 125 mm. Then, at the end of the stroke of the ram, the force build-up causes the deformation tube to activate for a 300 mm stroke.
- At the front of Car 1, on each side of the coupler, the anti-climbers engage (minimising vertical movement to prevent intrusion into the passenger area) and the crash boxes on each side are activated for a stroke of 750 mm.
- Between Car 1 and Car 2, the semi-permanent coupler gas-hydraulic buffer engages for a stroke of 125 mm. Then, at the end of the stroke of the ram, the force build-up causes the deformation tube to activate for a 125 mm stroke.
- Between Car 1 and Car 2, on each side of the coupler, the anti-climbers engage with each other and the crash boxes on each side are activated for a stroke of 300 mm in conjunction with the remaining stroke of the deformation tube.
- The between-cars energy transfer by the semi-permanent couplers and the crash boxes is repeated for the rest of the cars progressively along the train.

**A42 damage description following collision**

The initial observation of the train revealed that damage was mainly confined to the front of the train and the areas between the cars. The body of the cars and interior passenger areas showed little visible damage or deformation. Predictably, the further from the impact zone, the lesser damage level.

More comprehensive and intrusive inspections of the train and its components were carried out in the months following the collision. These inspections found that the front of the train, car D6342, sustained damage to the coupler, anti-climbers, the emergency door, the tread plate, the cab canopy, the GRP panels, wiring and piping. The intercar areas between all cars sustained some damage; this included couplers, anti-climbers, crash boxes, gangways, door panels and electrical connecting cables. Various cars sustained damage to their end walls and collision pillars. A more detailed summary of damage is shown in Table 4.

**Figure 24: A42 car numbering**

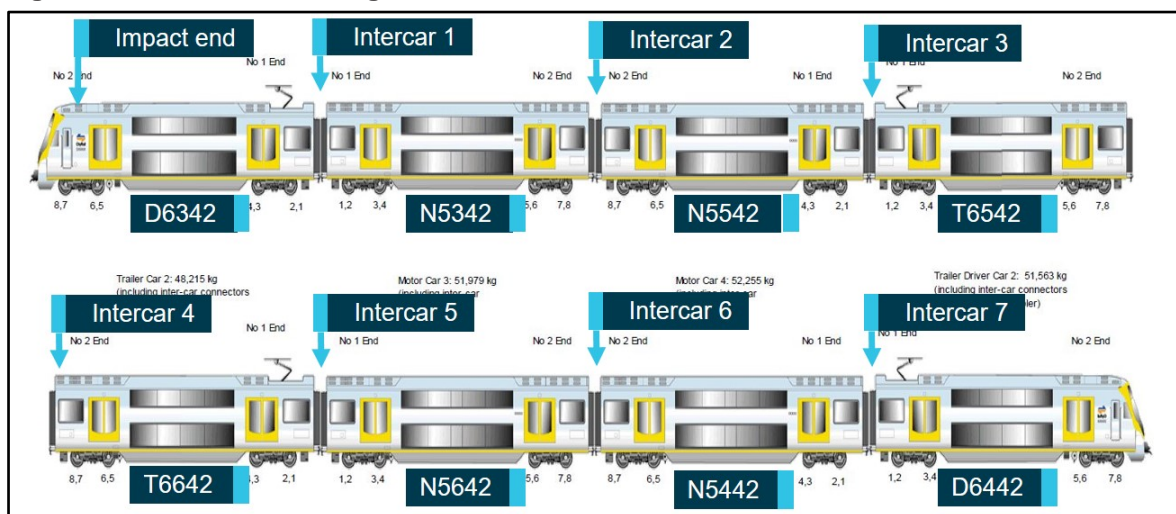

Source: Downer with annotations by ATSB



**Table 4: Damage summary sustained to A42.**

Location	Damage summary
Impact end	Damaged coupler, damaged tread plate, damaged GRP panels, damaged cab canopy.
Intercar 1	Damaged gangway, severely damaged and bent coupler, damaged intercar jumper cables, damaged GRP and end wall structure, anti-climber engagement, coupler indented into draft gear pocket.
Intercar 2	Damaged gangway, severely damaged and bent coupler, damaged intercar jumper cables, damaged GRP and end wall structure, damage to 1500V DC junction box, N5542 intercar door jammed.
Intercar 3	Damaged gangway, severely damaged coupler and drift ring fractured, N5542 sitting atop T6542 anti-climbers, damaged intercar jumper cables, T6542 intercar door jammed.
Intercar 4	Damaged gangway, damaged coupler, damaged gangway GRP and end panel.
Intercar 5	Damaged gangway, damaged coupler, damaged gangway GRP and end panel.
Intercar 6	Damaged coupler, gangway roof collapsed.
Intercar 7	Gangway roof collapsed.

Source: Downer

### **Performance of A42 CEMS**

The CEMS on Waratah passenger train A42 reduced the impact force of the collision but did not perform optimally. It did not perform as the design or modelling predicted. It should be noted that collision energy was reduced by the presence and performance of a CEMS, which likely lessened the injury level of passengers. The type of collision with a buffer stop, like the Richmond buffer stop, was not one of the scenarios specified in the original train performance specification.<sup>75</sup>

Downer evaluated the impact speed from a number of data sources and concluded that the impact speed was in the range of 26 km/h ± 2 km/h. A small variation in velocity has a significant effect on the impact energy. For instance, the impact speed at 28 km/hr has a kinetic energy of 12 MJ while the impact speed of 24 km/hr has a kinetic energy of 9 MJ.

According to calculations by Downer, a simulation of the Richmond collision predicted that 7.5 MJ (or approximately 70%) of the collision energy would be absorbed by the CEMS. The remainder of the energy would be absorbed by the eight-car body structure.<sup>76</sup> It was estimated that 4.5 MJ (or approximately 40%) of collision energy was actually absorbed by the CEMS during the Richmond collision. There were inconsistencies between predicted and actual behaviour of the CEMS:

- The predicted forces and decelerations experienced by the cars were significantly greater than the design load cases.
- There was inconsistency between simulation results and post-collision observations where the actual structural damage is considered to be minor with no failure at equipment mounts.
- There were significant portions of unaccounted energy.<sup>77</sup>

The rapid deceleration of A42 on impact caused pitching on the suspension in relation to the car's centre of gravity, because the CEMS did not activate properly and fully activate, due to the incompatibility between the CEMS and the Richmond buffer stop. A meeting, attended by representatives from Downer, Sydney Trains and TfNSW, discussing A42's performance recorded:

'The vehicle pitching meant that coupler angular displacement exceeded the 8-degree service limit, inducing significant bending in the shanks and in some cases preventing the couplers from fully stroking.

The induced bending of the coupler shanks is quite likely the reason why some of the intermediate couplers collapse tubes did not activate.

<sup>75</sup> RailCorp Rolling Stock PPP – Double Deck Trains Train Performance Specification v21, 22 December 2015. p.73-74.

<sup>76</sup> Downer CEC00903, Engineering calculation vehicle deceleration, 8 Feb 2019. p.9.

<sup>77</sup> Downer CEC00903, Engineering calculation vehicle deceleration, 8 Feb 2019. p.20.

Vehicle pitching of approximately 308 mm relative vertical displacement on some vehicle ends resulted in the anti-climbers being vertically misaligned between the car ends.<sup>78</sup>

Following the incident at Richmond, Downer, in consultation with Sydney Trains and TfNSW, have commissioned a third party to 3D model the collision. The results of this 3D modelling were inconclusive and Downer have completed their own linear modelling.

Downer conducted a comprehensive examination of the performance of each component of the CEMS. The table below lists the CEMS components for the eight cars, the calculated load absorption level (for estimated speed impact of 26 km/h), their maximum stroke displacement and the actual Richmond stroke displacement (Table 5).

**Table 5: CEMS components and force level, maximum stroke displacement and actual Richmond stroke displacement**

LOCATION	COMPONENT	FORCE (kN)	MAX STROKE (mm)	RICHMOND STROKE (mm)
LEAD END	Coupler (Gas Hydraulic)	2325	125	124
	Coupler (Deformation tube)	2325	300	115
	Crash boxes	2600	800	Left 0, Right 50
INTERCAR 1	Coupler (Gas Hydraulic)	2250	250	247
	Coupler (Deformation tube)	2250	300	215
		2250	300	39
	Crash boxes	600	300	Left 168, Right 175
INTERCAR 2	Coupler (Gas Hydraulic)	2125	250	250
	Coupler (Deformation tube)	2125	300	0-3
		2125	300	41
	Crash boxes	550	300	Left 194, Right 38
INTERCAR 3	Coupler (Gas Hydraulic)	1950	250	248
	Coupler (Deformation tube)	1950	300	300
	Crash boxes	2425	300	Left 4, Right 1
INTERCAR 4	Coupler (Gas Hydraulic)	1800	250	250
	Coupler (Deformation tube)	1800	300	300
	Crash boxes	1950	300	Left 10, Right 4
INTERCAR 5	Coupler (Gas Hydraulic)	1950	250	247
	Coupler (Deformation tube)	1950	300	115
	Crash boxes	2425	300	Left 0, Right 0
INTERCAR 6	Coupler (Gas Hydraulic)	2125	250	249
	Coupler (Deformation tube)	2125	300	0
		2125	300	9
	Crash boxes	550	300	Left 0, Right 0
INTERCAR 7	Coupler (Gas Hydraulic)	2250	250	223
	Coupler (Deformation tube)	2250	300	0
		2250	300	8
	Crash boxes	600	300	Left 0, Right 0

Source: Downer

<sup>78</sup> Downer meeting minutes 21 Jan 2019.

A few examples of the performance of A42's CEMS are shown below.

The front edge of both anti-climbers contacted the buffer tube flange on the face of the concrete buffer stop (Figures 25 and 26). The driver's side crash box activated and deformed rearwards by 50 mm; this damaged the fibreglass canopy and floor. The guard's side crash box did not activate despite the anti-climber also contacting the buffer tube flange (Figure 27). The maximum stroke for the crash box rams behind the anti-climber was 800 mm. It is possible the edge contact transferred angular force to the anti-climber, this did not allow the ram to slide and deform as designed.

**Figure 25: Position of anti-climbers on leading car**



*This figure shows position of the anti-climbers on the leading car of A42 and the edge which contacted the buffer tube flange.  
Source: ATSB*

**Figure 26: Damage from impact with anti-climbers**



*This figure shows the damage to the buffer stop tube flange (Right side) following contact with A42's RHS anti-climber (Left side) and the corresponding damage to the RHS anti-climber edge.  
Source: ATSB*



**Figure 27: Crash box ram from left side of A42 leading car**



*This figure shows the crash box ram being removed from A42. This ram did not activate during the collision as the contact area on the anti-climbers was at the side of the crash box on the radius of the outside corner of the anti-climber teeth. The anti-climber teeth fractured or sustained plastic flow under the extreme contact pressure and lost the force on the front of the crash box.*  
 Source: Downer with annotations by ATSB

The semi-permanent coupler between the first and second cars (Figure 28), and that between the second and third cars were bent and damaged. The vertical angular movement of the semi-permanent coupler is limited to 8 degrees (by design). This vertical limit was exceeded by the excessive pitching due to the CEMS not properly activating. The other four semi-permanent couplers also sustained damage. The anti-climbers between the third and fourth cars did not engage and instead one anti-climber damaged the 1500V DC junction box on the other car (Figure 29). The only semi-permanent coupler not to sustain damage was the semi-permanent coupler between the seventh and eighth cars.

**Figure 28: Bent semi-permanent coupler**

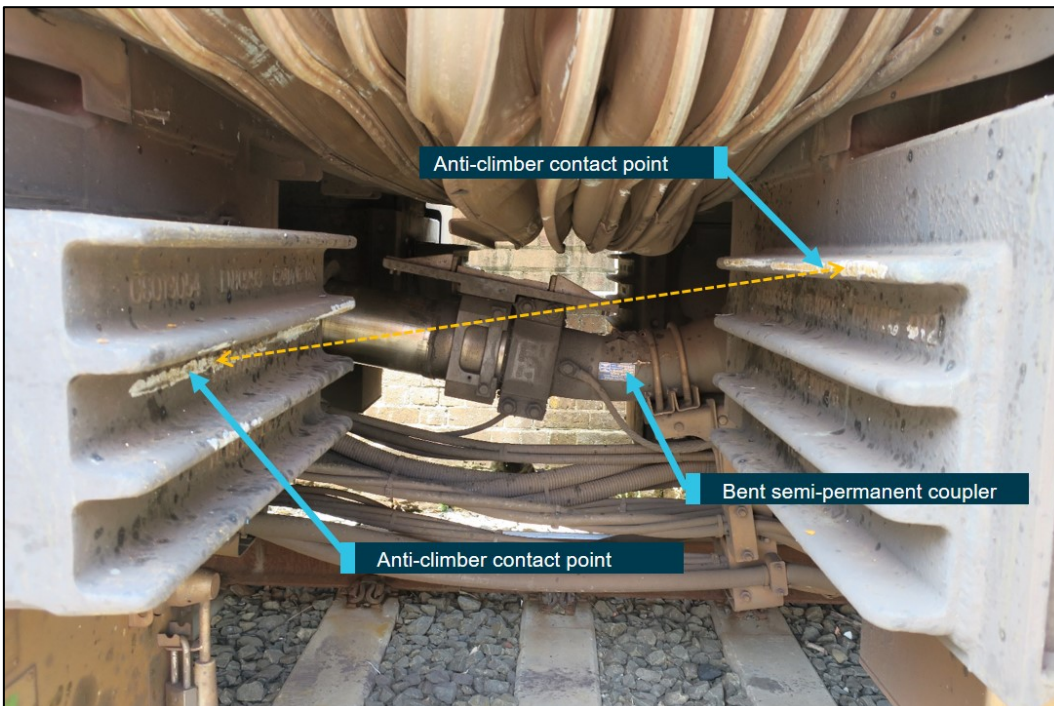

*This figure shows the bent coupler between the first and second cars (D6342 and N5342) and also the contact witness marks on the anti-climbers.*

Source: ATSB



**Figure 29: Anti-climber into junction box**

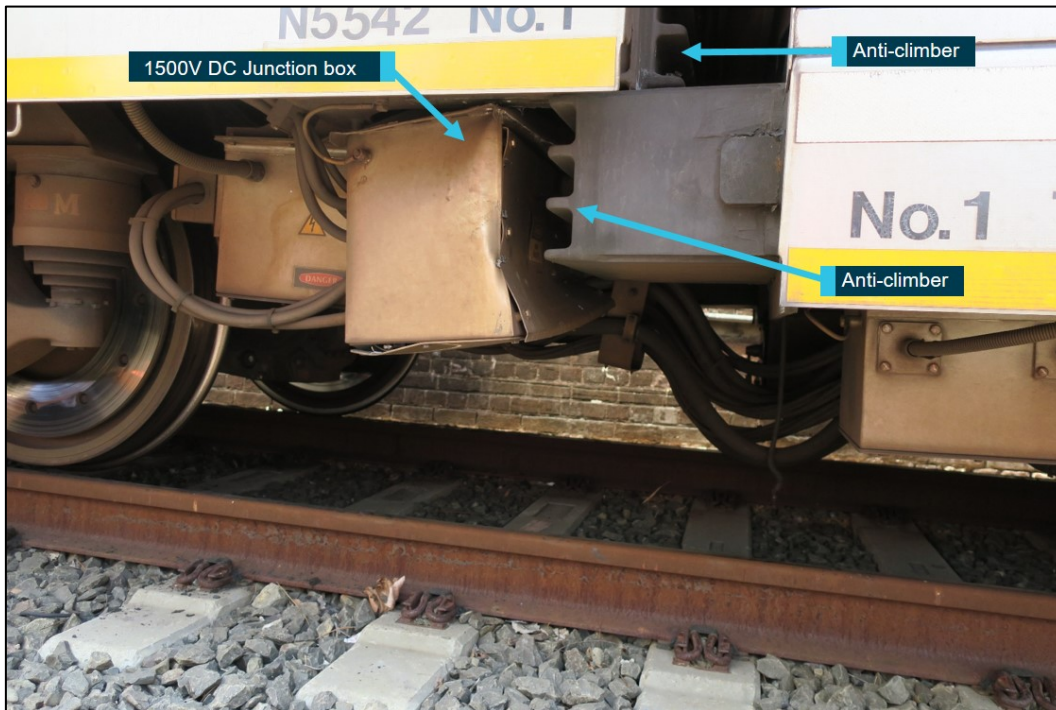

*This figure shows the No. 1 end of motor car N5542 overriding the No. 1 end of trailer car T6542, between the third and fourth cars. The anti-climber has damaged the 1500V DC junction box.  
Source: ATSB*

The bending of the couplers between the first two car interfaces, and the derailment of all wheels of a bogie (Figure 30), is indicative of vertical pitching that occurred because of the forces being transferred along the train not in a line of action close to the centreline through the couplers. This affected the alignment of the anti-climbers, which reduced their effectiveness in containing vertical movement (Figure 31).

**Figure 30: Derailed wheels**



*This figure shows the derailed wheels on the bogie on the No.1 end of the fifth car (T6642) (non-platform side).*

Source: ATSB

**Figure 31: Normal configuration of anti-climbers**

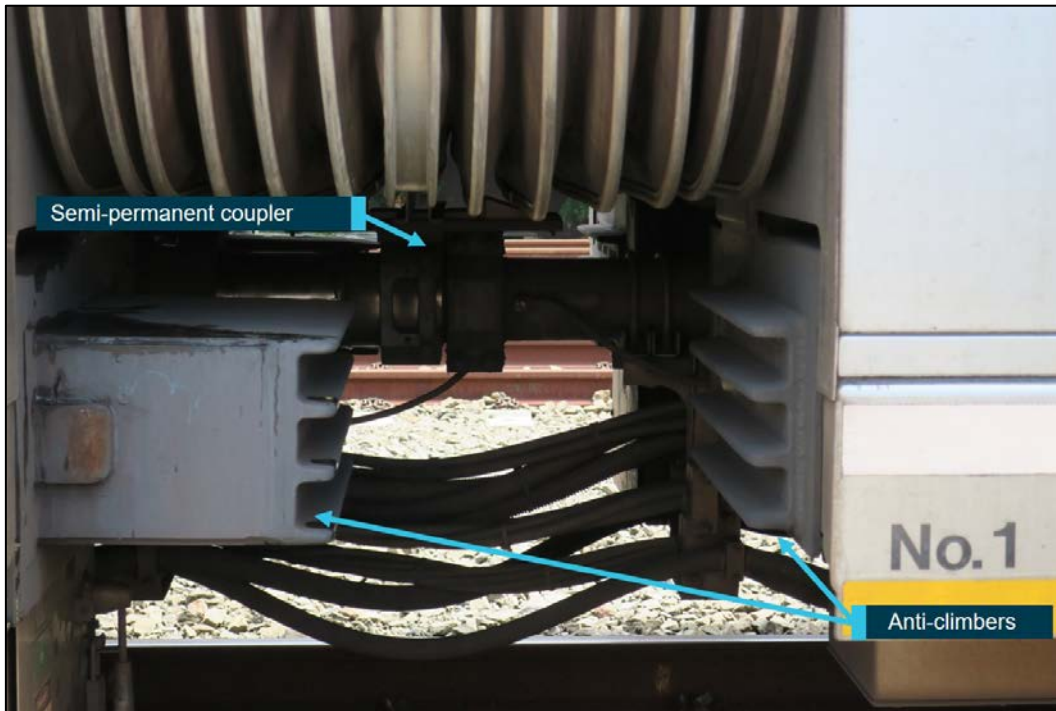

*This figure shows the anti-climbers in their normal configuration between the seventh car (N5442) and the eighth car (D6442).  
Source: ATSB*

The existence of CEMS on A-sets meant that the force experienced by the passengers was less than if they had been on another, older type of Sydney Trains rolling stock. It was estimated that the CEMS absorbed approximately 40% of the collision energy. The train bodysell showed no gross deformation and the seating fixtures and handrails all remained intact. All exterior passenger doors remained closed and windows unbroken. The passenger and crew blunt trauma injuries were likely caused by secondary impact with interior fittings or surfaces. None of the fittings contributed excessively to the injury toll. The impact inertia feature of the seats performed as designed, where the moveable seats locked under the impulsive collision force. Potential injury-causing mechanisms such as crushing, ejection, penetration or burns did not occur.

## Emergency response management

The notification of the incident to Triple Zero and the Rail Management Centre occurred within two minutes following the collision. Within ten minutes, NSW Fire & Rescue, NSW Police and NSW Ambulance were on site. At 1004, eleven minutes later, NSW Police took control of the site. During this time, paramedics, Sydney Trains staff and uninjured passengers assisted in evacuation and provided first aid to injured persons.

In accordance with his training, the station duty manager performed the notification task by placing a call to network control. Following the collision, the station customer service staff and other Sydney Trains employees present provided ongoing relevant information, directed and controlled the events on-site until the arrival of emergency services personnel.

The incident occurred at a staffed suburban station close to major facilities, which meant that staff were already on hand and the location did not present difficulties in terms of emergency services accessing the site. Triage of injured persons was conducted promptly and all services performed well in the stressful environment of the accident site. Open access to the accident site was required, especially during the initial evacuation and treatment period. Afterwards, a police demarcation tape and security personnel on Platform 2 kept the site partially secure from

contamination by non-involved persons. The investigation determined that the emergency response at Richmond was effective.

An examination of Sydney Trains emergency management documents found that Sydney Trains have detailed emergency management guidance for staff involved in responding to major emergencies such as occurred at Richmond. Prior to the incident, the station duty manager at Richmond had completed training in responding to a workplace emergencies, fire incidents and evacuation of a station.

According to Sydney Trains, since 2014 up to the time of the incident, they had conducted 38 evacuation exercises at various stations across the Sydney Trains network. These exercises involved conducting live evacuation drills with the objective of testing Sydney Trains' capability in responding to and managing incidents on stations across the Sydney Trains network.

The evacuation exercises were conducted across the network and at times involved over a hundred individuals at a time, mostly in conjunction with emergency services. The scenario in each of these exercises was similar and usually involved a bomb threat, utilising the fire management system, manipulating points and hand signalling at failed signals.

Other exercises conducted at regular intervals included:

- NSW Fire & Rescue train lift and rescue exercises
- Bushfire preparation
- Counter-terrorism exercises with Australian Defence Forces
- Bridge, train and tunnel evacuation
- Train and track familiarisation.

In addition, a local station desktop exercise was conducted at Richmond Station in October 2018 as part of the monthly station team briefing. The desktop exercise scenario related to a station power failure. No emergency preparedness exercise, desktop or otherwise, could be identified that included a passenger train collision with another train or a collision with a buffer stop.

## Organisational risk management

Sydney Trains manages operational risks through a safety management system that comprises 20 elements. These elements include: safety responsibilities, asset lifecycle management, and engineering and operational standards. This system contains a series of interconnected documents that describe what must be done to manage safety, who is responsible, and how certain tasks must be done. The element of 'Manage Operational Safety Risk' describes a cascading series of risk documents that identify and assess operational risks, assign control, monitor, and review the implementation of the controls.

Identified in the Sydney Trains safety risk register was the hazard of a passenger train overshooting a designated stop point at a station. The incapacitation of a rail vehicle driver was also identified as one of the potential causes of a passenger train overshooting a designated stop point at a station. Six causes for this incapacitation were listed: ill health, influence of drugs and/or alcohol, stress, fatigue, distraction and confusion. The relevant preventative controls for a rail vehicle driver incapacitation, and the status at the time of the incident, were given as:

- Automatic train protection (not operational at the time of the collision).
- Driver safety system (installed on A42 but did not detect the driver's incapacitation).
- Rail safety worker health assessment program.

The relevant mitigative controls for a rail vehicle driver incapacitation, relevant to the Richmond incident, were given as:

- Buffer stop design satisfies integrity requirements for absorbing an impact.
- Crashworthiness design of passenger train.



- Intermediate train stop (recommended for Richmond but was installed only after the collision). The buffer stop at Richmond did not absorb the impact as expected.

Sydney Trains, like all rail transport operators, is required to ensure, so far as is reasonably practicable, the safety of its railway operations.<sup>79</sup> So far as is reasonably practicable, Sydney Trains should have ensured the buffer stop at Richmond was designed, constructed, and maintained to appropriate standards that ensured safety on the day of the collision.

Sydney Trains responded in regards to whether the buffer stop at Richmond was suited to purpose and able to function as designed for the newer types of electric passenger rolling stock (such as the Waratah) at the time of the collision: 'Sydney Trains owns a large number of legacy equipment, which it acquired as part of the network infrastructure. The process of assessing this legacy equipment against present standards has been occurring on a priority-based system, due to the large number of items that require such an assessment. The buffer stop type at Richmond has not undergone the assessment process.'

The buffer stop at Richmond was one of 23 buffer stops identified as a high priority during an end-of-line risk prioritisation. The site had previously been identified as a high priority for additional safety measures in reports commissioned by RailCorp in 2005 and 2008. The integrated safety management system and the risk evaluation process, since the commencement of Sydney Trains in 2013, had not verified that the Richmond buffer stop was compatible with the rolling stock running on the Richmond line.

Once controls are in place, verification must be undertaken to ensure that the controls are effective at mitigating the risks to an acceptable level. A cohesive approach to risk management needs to ensure that no gaps exist in the verification of the control of safety risks.

Downer conducted risk assessments for a variety of scenarios including a collision between two trains or with buffer stop, due to adverse weather conditions (low adhesion) and inadequate crashworthiness of train. The controls for these identified risks included:

- VAMPIRE software used to address the crashworthiness requirements to verify the structural integrity of the design.
- Checks that the centre of gravity of the completed car was as low as reasonably practicable.
- A trade-off study on crashworthiness taking account of deformation tubes, gangway length, crumple zones and repair zones to confirm that an optimum crashworthiness design was achieved.
- All crashworthiness/assembly type testing was completed before the cars were manufactured, in order to eliminate any issues for train testing and commissioning.
- Ensured that checks for satisfactory condition of energy absorption components of the coupler and those incorporated in the car body structure.
- Reviewed the adequacy of crashworthiness design against the following prescriptive requirements:
  - (1) Structure to not fail by horizontal shearing between the car body shell and headstocks during the process of collapse.
  - (2) Not collapse in a way which might initiate overriding and/or telescoping of cars or derailment of cars.

---

<sup>79</sup> Office of the National Rail Safety Regulator (2014) Asset management guideline. 1.2.2. p.9.



- (3) Be constructed as to mitigate the possibility of injury to occupants and other persons from such causes as detachment of components from, or deformation of, the car body structure and the formation of sharp or jagged fracture edges.

## Findings

From the evidence available, the following findings are made with respect to the collision of Waratah passenger train, A42, with the buffer stop that occurred on number 2 platform at Richmond Station, New South Wales on 22 January 2018. These findings should not be read as apportioning blame or liability to any particular organisation or individual.

A safety issue is an event or condition that increases safety risk and (a) can reasonably be regarded as having the potential to adversely affect the safety of future operations, and (b) is a characteristic of an organisation or a system, rather than a characteristic of a specific individual, or characteristic of an operating environment at a specific point in time.

### Contributing factors

- The driver of A42 did not brake at a crucial time as the train approached the buffer stop at the end of Platform 2 at Richmond Station. There was a 22-second period where no inputs were made to the train's control system.
- It is possible that the driver of A42 experienced a loss of consciousness during this 22-second period as the train approached the buffer stop. A number of possibilities during the course of the investigation were examined, these included: the driver blacking out, the driver experiencing a microsleep due to fatigue impairment, or the driver being distracted / inattentive. It could not be conclusively determined what occurred during this period.

### Other factors that increased risk

- **When A42 collided with buffer stop at Richmond Station No. 2 platform, the reinforced concrete end stop of the buffer stop withstood the impact of the collision and prevented the train from crossing into a pedestrian and main road precinct. The two hydro-pneumatic rams on the front of the buffer stop did not perform their intended function. They were not aligned with the front of the Waratah train and instead of absorbing energy from the collision, they penetrated the cavity either side of the front-of-train coupler. (Safety issue)**
- **The crash energy management system on the Waratah passenger train A42 reduced the impact force of the collision but not all components performed as designed. The performance of the crash energy management system was significantly limited by the buffer stop at Richmond being incompatible with the front of the Waratah train. (Safety issue)**
- **Sydney Trains' risk management procedures did not sufficiently mitigate risk to the safe operation of trains in circumstances when there were deficiencies in the buffer stop design at Richmond and at other locations. (Safety issue)**
- **Sydney Trains' risk management procedures did not sufficiently mitigate risk to the safe operation of trains in circumstances where the presence of an intermediate train stop at Richmond may have reduced the risk of trains approaching the station at excessive speed. (Safety issue)**
- **The rostering of the driver in the days leading up to the incident was inconsistent with Sydney Trains' rostering procedures. (Safety issue)**

### Other findings

- The train's vigilance control system did not activate in the period where the driver experienced a possible loss of consciousness. The vigilance control system cycles were timed and tested and performed as designed.

- The operator enable system continued to be operated by the driver, despite the driver experiencing a possible loss of consciousness.
- The passenger areas on the Waratah passenger train A42 remained intact and free from deformation following the collision with the buffer stop.
- The driver was certified as medically fit to drive the train, in accordance with category A of the *National Standard for Health Assessment of Rail Safety Workers*, and had passed all previous medical assessments. Following the incident, he was subjected to further medical tests which could not identify any health issue apart from being diagnosed 8 months after the incident with moderate obstructive sleep apnea.
- The investigation determined that there was insufficient time for the guard to react and apply the emergency brakes. There were no clues for the guard that there was anything amiss until approximately 2 seconds before the collision. The train had entered the platform at a speed that was normal and the train was decelerating slightly under the influence of the electro-dynamic braking system.
- There was no fault found with the train's braking and control system.
- It was determined that the emergency response at Richmond was effective.
- The introduction of ATP will significantly control the risk of overrun incidents using engineering controls to supervise the train speed and enforce braking when necessary.
- The absence of inward facing in-cab audio and video recording meant that the investigation was unable to verify the driver's actions as the train approached the buffer stop at the end of Platform 2 at Richmond Station. It would be beneficial if in-cab audio and video recorders were installed in driver's compartments.

## Safety issues and actions

The safety issues identified during this investigation are listed in the Findings and Safety issues and actions sections of this report. The Australian Transport Safety Bureau (ATSB) expects that all safety issues identified by the investigation should be addressed by the relevant organisation(s). In addressing those issues, the ATSB prefers to encourage relevant organisation(s) to proactively initiate safety action, rather than to issue formal safety recommendations or safety advisory notices.

Depending on the level of risk of the safety issue, the extent of corrective action taken by the relevant organisation, or the desirability of directing a broad safety message to the rail industry, the ATSB may issue safety recommendations or safety advisory notices as part of the final report.

The initial public version of these safety issues and actions are repeated separately on the ATSB website to facilitate monitoring by interested parties. Where relevant the safety issues and actions will be updated on the ATSB website as information comes to hand.

### Crash energy management system did not perform as designed

<b>Safety issue number:</b>	RO-2018-004-SI-01
<b>Safety issue owner:</b>	Downer
<b>Operation affected:</b>	Rail: Rolling stock
<b>Who it affects:</b>	Rolling stock designers and rail infrastructure managers

#### ***Safety issue description:***

The crash energy management system on the Waratah passenger train A42 reduced the impact force of the collision but not all components performed as designed. The performance of the crash energy management system was significantly limited by the buffer stop at Richmond being incompatible with the front of the Waratah train.

#### ***Status of the safety issue***

<b>Issue status:</b>	Addressed
<b>Justification:</b>	The ATSB notes that the actions taken to examine the behaviour of the CEMS on A42 and the implementation of a compatible buffer stop design, once implemented, should address the safety issue.

#### ***Proactive safety action***

<b>Action taken by:</b>	Downer
<b>Action number:</b>	RO-2018-004-NSA-016
<b>Action type:</b>	Proactive safety action
<b>Action status:</b>	Closed

#### ***Safety action taken***

Downer, in consultation with Reliance Rail, Sydney Trains and TfNSW completed a comprehensive review of the collision with the buffer at Richmond and has concluded that the Richmond buffer did not interface with the Waratah train and in fact restricted the operation of the CEMS systems at the front of the train. Because of the restricted energy absorption at the front



end of the train this generated high vehicle decelerations causing the train carriages to pitch in excess of the design range of the coupler and inter car anti-climbers.

## Buffer stop effectiveness in collision

<b>Safety issue number:</b>	RO-2018-004-SI-02
<b>Safety issue owner:</b>	Sydney Trains
<b>Operation affected:</b>	Rail: Infrastructure
<b>Who it affects:</b>	Rail infrastructure managers

### ***Safety issue description:***

When A42 collided with buffer stop at Richmond station No. 2 platform, the reinforced concrete end stop of the buffer stop withstood the impact of the collision and prevented the train from crossing into a pedestrian and main road precinct. The two hydro-pneumatic rams on the front of the buffer stop did not perform their intended function. They were not aligned with the front of the Waratah train and instead of absorbing energy from the collision, they penetrated the cavity either side of the front-of-train coupler.

### ***Status of the safety issue***

<b>Issue status:</b>	Addressed
<b>Justification:</b>	The ATSB notes that the action to replace the buffer stops at Richmond, once implemented, should address the safety issue.

### ***Proactive safety action***

<b>Action taken by:</b>	Sydney Trains
<b>Action number:</b>	RO-2018-004-NSA-017
<b>Action type:</b>	Proactive safety action
<b>Action status:</b>	Closed

### ***Safety action taken***

Sydney Trains have redesigned the buffer stops for Richmond Station Platform 1 and 2. The new Platform 1 buffer concrete block was installed in April 2019. The Platform 2 buffer concrete block is planned for installation in January 2020. The buffers stop rams are planned for installation in February 2020.

## Management of risk associated with buffer stop deficiencies

<b>Safety issue number:</b>	RO-2018-004-SI-03
<b>Safety issue owner:</b>	Sydney Trains
<b>Operation affected:</b>	Rail: Infrastructure
<b>Who it affects:</b>	Rail infrastructure managers

### ***Safety issue description:***

Sydney Trains' risk management procedures did not sufficiently mitigate risk to the safe operation of trains in circumstances when there were deficiencies in the buffer stop design at Richmond and at other locations.

### ***Status of the safety issue***

<b>Issue status:</b>	Addressed
----------------------	-----------

**Justification:** The ATSB notes that the action initiated by Sydney Trains, once implemented, should address the safety issue.

### ***Proactive safety action***

**Action taken by:** Sydney Trains  
**Action number:** RO-2018-004-NSA-018  
**Action type:** Proactive safety action  
**Action status:** Closed

### ***Safety action taken***

Sydney Trains in consultation with external stakeholders, redesigned the buffer stop to be compliant with the ASA buffer stop standard. This design will be the template for replacement of other buffer stops on the Sydney metropolitan rail network. Sydney Trains has commenced a program to upgrade buffer stops throughout the network using a risk prioritisation model.

## **Management of risk associated with intermediate train stop installation**

**Safety issue number:** RO-2018-004-SI-04  
**Safety issue owner:** Sydney Trains  
**Operation affected:** Rail: Infrastructure  
**Who it affects:** Rail infrastructure managers

### ***Safety issue description:***

Sydney Trains' risk management procedures did not sufficiently mitigate risk to the safe operation of trains in circumstances where the presence of an intermediate train stop at Richmond may have reduced the risk of trains approaching the station at excessive speed.

### ***Status of the safety issue***

**Issue status:** Addressed  
**Justification:** The ATSB notes that the signalling upgrade and the introduction of ATP, once implemented, should address the safety issue.

### ***Proactive safety action***

**Action taken by:** Sydney Trains  
**Action number:** RO-2018-004-NSA-019  
**Action type:** Proactive safety action  
**Action status:** Closed

### ***Safety action taken***

Sydney Trains have completed a signalling upgrade at Richmond, including intermediate train stops to control the approach speed. As well, implementation of the ATP project will control the risk of overrun incidents using engineering controls to supervise the train speed and enforce braking when necessary.

## **Rostering of the driver inconsistent with rostering principles**

**Safety issue number:** RO-2018-004-SI-05  
**Safety issue owner:** Sydney Trains

**Operation affected:** Rail: Passenger-metropolitan

**Who it affects:** Rail rostering managers

***Safety issue description:***

The rostering of the driver in the days leading up to the incident was inconsistent with Sydney Trains' rostering principles.

***Status of the safety issue***

**Issue status:** Not addressed

**Justification:** The ATSB makes the following recommendation so that actions to address the safety issue are effectively monitored and reported.

***ATSB safety recommendation to Sydney Trains***

**Action number:** RO-2018-004-SR-020

**Action status:** Monitor

The Australian Transport Safety Bureau recommends that Sydney Trains take safety action to ensure that existing procedures regarding adequate rest breaks between shift cycles and start time rotations are reinforced to safeguard against fatigue impairment of train crew.

# General details

## Occurrence details

Date and time:	22 January 2018 at 0951 EDT	
Occurrence category:	Accident	
Primary occurrence type:	Collision	
Location:	Richmond, New South Wales	
	Latitude: 33° 35.93' S	Longitude: 150° 45.142' E

## Train details

Train operator:	Sydney Trains	
Registration:	A42	
Type of operation:	Passenger	
Persons on board:	Crew – 2	Passengers – 24
Injuries:	Crew – 2	Passengers – 14
Damage:	Substantial	



# Sources and submissions

## Sources of information

The sources of information during the investigation included:

- Downer
- NSW Police
- NSW Ambulance
- The Office of the National Rail Safety Regulator
- Sydney Trains
- Train crew of A42
- Transport for NSW – Asset Standards Authority
- The Transportation Safety Board of Canada
- The National Transportation Safety Board (USA)
- The Federal Railroad Administration (USA)

## References

Australian Transport Safety Bureau. Rail investigation report (2013). *RO-2013-005, Collision of passenger train T842 with station platform at Cleveland, Queensland*. Published 20 December 2013.

Australian Standard (2018). AS 7521:2018 *Interior crashworthiness*.

Battelle Memorial Institute (1998). *An Overview of the scientific literature concerning fatigue, sleep, and the circadian cycle*. Report prepared for the Office of the Chief Scientific and Technical Advisor for Human Factors, United States Federal Aviation Administration.

British Standard (2010). *BS EN 15227:2008 +A1:2010 – Railway applications - Crashworthiness requirements for railway vehicle bodies*.

Civil Aviation Safety Authority Australia (2014). *Bio-mathematical fatigue models – Guidance document*.

Dawson D., Noy YI, Harma M, Akerstedt T, Belenky G. (2011). *Modelling fatigue and the use of fatigue models in work settings*. Accident Analysis and Prevention. Vol 43.

Desai AV, Ellis E, Wheatley JR, Grunstein RR. (2003). Medical Journal of Australia. Vol. 178. *Fatal distraction: a case series of fatal fall-asleep road accidents and their medicolegal outcome*.

Downer (2009). *Static Twist Test Simulation, CEC00594 – CN01, 23 April 2009*.

Downer (2009). *Engineering Report CN01- crashworthiness methodology, CER01484, 25 April 2009*.

Downer (2009). *Engineering Report – FEA of energy absorbing crash boxes, 15 May 2009*.

Downer (2010). *Rolling Stock PPP Sets – Mass Estimation, CEC00523, 8 July 2010*.

Downer (2010). *Dynamic Crash Test, PAU817-012, 15 July 2010*.

Downer (2011). *Engineering test report, CTR00710-001, 5 November 2011*.

Downer (2011). *PPP Trains crashworthiness risk Review Delta Rail Report - Body crashworthiness risk assessment 2009 p.14. 8 November 2011*.

Downer (2019). *Meeting minutes 21 January 2019*.

Downer (2019). *CEC00903 Engineering calculation vehicle deceleration, 8 February 2019*.

- Federal Government of the United States (2015). *Fixing America's Surface Transportation Act – Public Law*. 114th Congress Public Law 94, 2015, Sec. 11411.
- Folkard S, Robertson KA, Spenser MB (2006). *The development of a fatigue / risk index for shiftworkers*.
- McInerney, PA. (2004). *Interim Report of the Special Commission of Inquiry's report into the Waterfall rail accident*.
- National Transport Commission (2008). *National Rail Safety Guideline. Management of Fatigue in Rail Safety Workers*.
- National Transport Commission (2017). *National Standard for Health Assessment of Rail Safety Workers*. p.72.
- National Transportation Safety Board (2019). *Most Wanted List of Transportation Safety Improvements 2019-2020*. [www.nts.gov/mostwanted](http://www.nts.gov/mostwanted)
- National Transportation Safety Board (2017). *Special Investigation Report, End-of-track collisions at Terminal Stations Hoboken, New Jersey, 29 September, 2016 and Atlantic Terminal, Brooklyn, New York, 4 January 2017*. NTSB/SIR-18/01.
- New South Wales Passenger Transport Regulation 2017 cl. 82.
- New South Wales Department of Transport. *Independent Inquiry Report, Coal Train Collision, Beresfield, NSW, 23 October 1997*.
- Office of the National Rail Safety Regulator (2011). *Rail Safety Compliance Code – Data Loggers*. Section 4.
- Office of the National Rail Safety Regulator (2018). *Implementation of the NSW Government's response to the Final Report of the Special Commission of Inquiry's report into the Waterfall rail accident*.
- Office of the National Rail Safety Regulator Asset management guideline s52 (1).
- Pack A, Pack AM, Rodgman E, Cucchiara A, Dinges DF, Schwab CW. *Accident Analysis and Prevention*. Vol. 26. (1995). *Characteristics of crashes attributed to the driver having fallen asleep*.
- Rail Industry Safety and Standards Board (2010). *Glossary of Rail Terminology*.
- RailCorp Rolling Stock PPP – *Double Deck Trains Train Performance Specification v21*, 22 December 2015.
- Regan MA, Strayer DL. (2014). *Towards an understanding of driver inattention: taxonomy and theory*. *Journal of the Association for the Advancement of Automotive Medicine*.
- Senders JW. (2013). *Driver distraction and inattention: a queueing theory approach*. *Driver distraction and inattention. Advances in Research and Countermeasures*. Ashgate.
- Sinclair Knight Merz (SKM) (2005). *Report on existing overrun protection at terminal tracks and proposals for upgrades*.
- Sinclair Knight Merz (SKM) (2008). *Buffer stops at Richmond and Carlingford*.
- Stichting Elilpesie Instellingen Nederland (SEIN) (2019). *The blackout checklist*.
- Stutts JC, Wilkins JW, Osberg JS, Vaughn. (2003). *Driver Risk Factors for Sleep-related Crashes, Accident Analysis and Prevention*.
- Sydney Trains / Downer, *Brakes RTM00001-100B*. p.61 (Undated).
- Transport for New South Wales – Asset Standards Authority (2017). *Standard T MU RS 01000 ST Structural integrity and crashworthiness of passenger rolling stock*.
- Transport for New South Wales – Asset Standards Authority (2017). *Standard T HR TR 25000 ST Buffer Stops, Version 1.0, Issued: 10 July 2017*.

- Transport for New South Wales – Asset Standards Authority. Standard RSU 100 Series – *Minimum Operating Standards for Rolling Stock – General Interface Requirements 7.5.1.*
- Transport for New South Wales – Asset Standards Authority (2016). *Train (Driver) Safety System, T HR RS 00840 ST, v2.0*, issued 4 November 2016.
- Transport for New South Wales (2018). TOC Waiver TW 203-629, *Locomotive Hauling of Waratah cars from set A42*. Issued 1 February 2018.
- Transportation Safety Board of Canada (2014). *Guide to investigating sleep-related fatigue*.
- Transportation Safety Board of Canada (2013). *TSB Recommendation R13-02*.
- UK Rail Safety and Standards Board (2004). *Human Factors study of fatigue and shift work. Appendix 1: Working patterns of train drivers: implications for fatigue and safety*.
- US National Transportation Safety Board (1997). *Safety Recommendation RAR-97/02 from Collision and Derailment of Maryland Rail Commuter MARC Train 286 and National Railroad Passenger Corporation Amtrak Train 29 Near Silver Spring, Maryland, on February 16, 1996*.
- US National Transportation Safety Board (2010). *NTSB Safety Recommendation R-10-001*.
- WedMD - Brain and nervous system – Understanding fainting [www.webmd.com](http://www.webmd.com) (accessed 1 December 2018).

## Submissions

Under Part 4, Division 2 (Investigation Reports), Section 26 of the *Transport Safety Investigation Act 2003* (the Act), the Australian Transport Safety Bureau (ATSB) may provide a draft report, on a confidential basis, to any person whom the ATSB considers appropriate. Section 26 (1) (a) of the Act allows a person receiving a draft report to make submissions to the ATSB about the draft report.

A draft of this report was provided to Downer, the Office of National Rail Safety Regulator, Sydney Trains, Transport for NSW and the train crew of A42.

Submissions were received from Downer, the Office of National Rail Safety Regulator, Sydney Trains, and Transport for NSW. The submissions were reviewed and where considered appropriate, the text of the draft report was amended accordingly.

## Glossary

Anti-climbers – plates attached to the leading and intercar ends of the train to prevent overriding in a collision.

Asset Standards Authority (ASA) – the ASA, as part of Transport for NSW, is the network design and standards authority for NSW transport assets. The ASA's functions encompass all transport modes alongside organisational management systems, safety systems and environmental policy.

Automatic Train Protection (ATP) – a system which supervises train speed and target speed, alerts the driver of the braking requirement, and enforces braking when necessary. The system may be intermittent, semi-continuous or continuous according to its track-to-train transmission updating characteristics.

Buffer stop – mass concrete block or energy-absorbing device to stop train overrun – usually located at the end of the line (terminating station, sidings or train servicing facility roads).

Buffer stop rams – energy-absorbing hydraulic devices positioned on a buffer stop to contact with train impact point.

Coupler – the mechanism for joining two rail vehicles together.

Crash boxes – box fitted to the leading and intercar ends of the train to absorb energy in the event of a collision. (The anti-climber plate is attached to the face of the crash box.)

Crash emergency management system (CEMS) – a system integrated into a vehicle body design for controlling the energy absorbed, deceleration and structural deformation during crashes, in particular collisions.

Crashworthiness – ability to mitigate the consequences of a collision in a controlled manner and reduce the risk of injury to the occupants.

Fixed Train Stop – a device for applying train brakes if the driver exceeds the limit of authority; either at a red signal or dead end stopping point, by the means of a lever on the train striking a trackside arm.

Intermediate train stops – mechanical trackside arms, spaced intermediately on approach to a risk point, and designed to apply the emergency train brakes if the speed of the train exceeds the safe stopping speed as measured by the signal timing of the train speed in the section.

Operator Enable System (OES) – a device that applies emergency brakes and disables traction power if a continuous control input required of the driver or operator is interrupted or not detected. On conventional vehicles with an automatic brake, the emergency brake is achieved by directly venting the brake pipe to atmosphere.

Overriding – an undesirable outcome of a train collision when the end of a train car lifts vertically relative to the adjoining car.

Overrun – where a train passes a designated stopping point such as a platform or signal.

Train stop and trip gear system – a system involving a trip valve on the train or vehicle and a trip arm located track side which when engaged, directly vents the brake pipe on the train or vehicle to atmosphere. The train stop is used at signals in conjunction with a red aspect and in areas where train speed is required to be externally controlled.

Vigilance control system – a system that will react by bringing a vehicle or train to a stand if an acknowledgment input is not received within a specified time increment. On conventional vehicles with an automatic brake, this is achieved by directly venting the brake pipe to atmosphere.



# Australian Transport Safety Bureau

The Australian Transport Safety Bureau (ATSB) is an independent Commonwealth Government statutory agency. The ATSB is governed by a Commission and is entirely separate from transport regulators, policy makers and service providers. The ATSB's function is to improve safety and public confidence in the aviation, marine and rail modes of transport through excellence in: independent investigation of transport accidents and other safety occurrences; safety data recording, analysis and research; fostering safety awareness, knowledge and action.

The ATSB is responsible for investigating accidents and other transport safety matters involving civil aviation, marine and rail operations in Australia that fall within Commonwealth jurisdiction, as well as participating in overseas investigations involving Australian registered aircraft and ships. A primary concern is the safety of commercial transport, with particular regard to operations involving the travelling public.

The ATSB performs its functions in accordance with the provisions of the *Transport Safety Investigation Act 2003* and Regulations and, where applicable, relevant international agreements.

## Purpose of safety investigations

The object of a safety investigation is to identify and reduce safety-related risk. ATSB investigations determine and communicate the factors related to the transport safety matter being investigated.

It is not a function of the ATSB to apportion blame or determine liability. At the same time, an investigation report must include factual material of sufficient weight to support the analysis and findings. At all times the ATSB endeavours to balance the use of material that could imply adverse comment with the need to properly explain what happened, and why, in a fair and unbiased manner.

## Developing safety action

Central to the ATSB's investigation of transport safety matters is the early identification of safety issues in the transport environment. The ATSB prefers to encourage the relevant organisation(s) to initiate proactive safety action that addresses safety issues. Nevertheless, the ATSB may use its power to make a formal safety recommendation either during or at the end of an investigation, depending on the level of risk associated with a safety issue and the extent of corrective action undertaken by the relevant organisation.

When safety recommendations are issued, they focus on clearly describing the safety issue of concern, rather than providing instructions or opinions on a preferred method of corrective action. As with equivalent overseas organisations, the ATSB has no power to enforce the implementation of its recommendations. It is a matter for the body to which an ATSB recommendation is directed to assess the costs and benefits of any particular means of addressing a safety issue.

When the ATSB issues a safety recommendation to a person, organisation or agency, they must provide a written response within 90 days. That response must indicate whether they accept the recommendation, any reasons for not accepting part or all of the recommendation, and details of any proposed safety action to give effect to the recommendation.

The ATSB can also issue safety advisory notices suggesting that an organisation or an industry sector consider a safety issue and take action where it believes it appropriate. There is no requirement for a formal response to an advisory notice, although the ATSB will publish any response it receives.

## Australian Transport Safety Bureau

**Enquiries** 1800 020 616

**Notifications** 1800 011 034

**REPCON** 1800 020 505

**Web** [www.atsb.gov.au](http://www.atsb.gov.au)

**Twitter** @ATSBinfo

**Email** [atsbinfo@atsb.gov.au](mailto:atsbinfo@atsb.gov.au)

**Facebook** [atsbgovau](https://www.facebook.com/atsbgovau)

**LinkedIn** [Australian Transport Safety Bureau](https://www.linkedin.com/company/atsb)

## Investigation

### **ATSB Transport Safety Report** Rail Occurrence Investigation

Collision of passenger train A42 with buffer stop  
Richmond, New South Wales, on 22 January 2018

RO-2018-004

Final – 20 December 2019