



Australian Government
Australian Transport Safety Bureau

Safe Transport

RAIL SAFETY INVESTIGATION
2003/004

Derailment of Train 6WP2

Bates, South Australia
9 November 2003





Australian Government

Australian Transport Safety Bureau

RAIL SAFETY INVESTIGATION
2003/004

Rail Safety Investigation into the Derailment of Train 6WP2

**in Bates, South Australia
on 9 November 2003**

This report is the result of an independent investigation carried out by the Australian Transport Safety Bureau (ATSB). The ATSB is an operationally independent multi-modal Bureau within the Australian Government Department of Transport and Regional Services. The ATSB's objective is safe transport. It seeks to achieve this through: independent investigation of transport accidents and other safety occurrences; safety data research and analysis; and safety communication and education.

The ATSB operates within a defined legal framework and undertakes investigations and analysis of safety data without fear or favour. Investigations, including the publication of reports as a result of investigations, are authorised by the Executive Director of the ATSB in accordance with the *Transport Safety Investigation Act 2003* (TSI Act).

Readers are advised that ATSB investigations are for the sole purpose of enhancing transport safety. Consequently, Bureau reports are confined to matters of safety significance and may be misleading if used for other purposes. Reports released under the TSI Act are not admissible in any civil or criminal proceedings.

As the ATSB believes that safety information is of greatest value if it is passed on for the use of others, readers are encouraged to copy or reprint this report for further distribution, acknowledging the ATSB as the source.

Acknowledgment

The map section identified in this publication is reproduced by permission of Geoscience Australia, Canberra. Crown Copyright ©. All rights reserved.
www.ga.gov.au

Other than for the purposes of copying this publication for public use, the map information from the map section may not be extracted, translated, or reduced to any electronic medium or machine readable form for incorporation into a derived product, inwhole or in part, without prior written consent of Geoscience Australia, Canberra.

CONTENTS

INTRODUCTION	v
EXECUTIVE SUMMARY	vii
1 OVERVIEW	1
1.1 Location	1
1.2 The occurrence	2
1.3 Personnel involved	5
1.4 Injuries	6
1.5 Medical and toxicology information	6
1.6 Train Information	6
1.6.1 Train 6WP2	6
1.6.2 Wagon RKCX24	6
1.6.3 Wagon axle mounted bearings	7
1.7 Track infrastructure details	9
1.8 Loss or damage	9
1.9 Train control information	10
1.10 Environmental factors	10
1.11 Accident site information	10
1.12 Details of fire	11
1.13 Dangerous goods	11
2 KEY ISSUES	13
2.1 Introduction	13
2.2 Test and research details	13
2.2.1 Failed RBU (305809)	13
2.2.2 Bearing cage – RBU 305809	14
2.2.3 Interference fit	16
2.2.4 Bogie and wheel sets	17
2.2.5 Opposite end RBU (305842)	18
2.2.6 Bearing care	20
2.2.7 Assembling of RBU	21
2.2.8 Bearing lubrication	22
2.2.9 Bearing seals	22
2.2.10 Bearing adapter casting	22
2.2.11 Rollingstock maintenance	23

2.3	Monitoring of rollingstock condition	24
2.3.1	Monitoring of rollingstock	24
2.3.2	Wheel condition monitoring systems	26
2.3.3	Rail bearing acoustic monitor	27
2.3.4	Wheel condition monitor and bearing acoustic monitor combined analysis	30
2.3.5	History of similar bearing incidents	32
2.4	Operations	32
2.4.1	Train examination and inspection	32
2.4.2	Train operation	33
3	CONCLUSIONS	35
3.1	Cause of derailment	35
3.2	Findings	35
3.3	Contributing factors	35
4	SAFETY ACTIONS	37
4.1	Actions taken	37
4.2	Recommendations	37
4.2.1	Pacific National	38
4.2.2	South Australian Railway Safety Regulator	39
4.2.3	Australian Rail Track Corporation	39
5	SUBMISSIONS	41
6	APPENDICES	43
6.1	Bearing, bogie, and wheel component details	43
6.2	Bogie, wheel, and failed bearing component details	44
6.3	Bearing unit component details – opposite end to failed RBU	44
6.4	Bearing acoustic monitor data	45
6.5	Bearing acoustic monitor data – opposite RBU	47

INTRODUCTION

Following the derailment of wagon number RKCX24 on train 6WP2 operated by Pacific National (PN) immediately west of the Bates crossing loop in South Australia on Sunday 9 November 2003, the Executive Director of the Australian Transport Safety Bureau (ATSB) authorised an independent investigation into the causal factors contributing to the accident with a view to encouraging safety action and to reduce the risk of future accidents.

EXECUTIVE SUMMARY

Train 6WP2 operated by Pacific National Ltd (PN) derailed at 2222 (central summer time) on Sunday 9 November 2003 as it was passing through Bates, South Australia. The train had departed Port Augusta that morning and was proceeding to Perth, Western Australia.

The derailment was limited to wagon number RKCX24 positioned 21st in a train of 73 wagons. The condition of a Roller Bearing Unit (RBU) on the right hand third axle of the wagon had progressively deteriorated to a point where friction induced heat caused the portion of axle between the RBU and the wheel to become 'plastic'¹ causing the RBU to seize where upon the axle separated or 'screwed' off as the axle turned.

After approximately 200 metres in this state, the leading end bogie side frame dropped to the outside of the right hand rail. The wheels did not leave the rails until reaching the western end of Bates, where the crossing loop points caused a destabilising effect. The train was brought to a stop in just over 1000 metres by the train crew from a speed at the time of derailment of 77 km/h.

Approximately 1,275 metres of track sleepers and 150 metres of rail were damaged as a result of the derailment. No injuries were reported and no dangerous goods were involved.

It was concluded that train 6WP2 derailed due to the failure of a RBU on wagon RKCX24. A number of causal factors relating to bearing roller assembly cage failure were identified in the investigation associated with: bearing refurbishment and assembly; storage; and handling of the wheel set.

Contributing factors:

- From the investigation evidence it was found that the most likely cause of the RBU failure was roller assembly cage failure leading to inner ring loss of interference fit on the axle journal.
- The workshop assembling and fitting of the RBU to the axle journal was a possible contributing factor to cage failure based on the short service life of the unit.
- There was some evidence of lateral movement, due to excessive end-play, within the intact RBU at the opposite end of the axle to the failed RBU. Such movement could probably have contributed to the failure of the RBU.
- Probable water ingress from less than optimum storage of the RBU was suggested by evidence, as detected by Bearing Acoustic Monitoring systems (RailBAM).
- The radius of the RBU at the opposite end of the axle to the failed RBU was out of specification and displayed signs of rust.
- Validated procedures for RailBAM to provide guidelines for its use had not been put in place by PN or the Australian Rail Track Corporation (ARTC).

¹ The ability of a metal to be deformed extensively without rupture.

- The interim criteria adopted by PN for removing high risk wagons, based on the RailBAM and Wheel Condition Monitoring (WCM) data, did not identify wagon RKCX24 as having a reading sufficiently serious to remove it from service.

The report recommends that:

- PN undertake a review and implementation of remedial action as required of workshop processes for the care and fitment of bearings to make sure that appropriate measures are in place to reduce the risk of subsequent cage related failure.
- PN undertake a review and implementation of remedial action as required of the storage, transportation, and handling of bearings to make sure that appropriate measures are in place to reduce the risk of accidental damage, particularly with regard to stored RBUs fitted to wheel sets.
- PN undertake a review and implement remedial action as required of the refurbishment and assembly of bearings.
- PN further develop and validate their procedure for the use of WCM systems.
- PN continue their utilisation of RailBAM with a view to improving the application of the information provided as soon as practicable and in line with their Major Hazard Action Plan.
- PN and the ARTC develop and validate a procedure for the use of RailBAM.
- The South Australian Railway Safety Regulator monitor the implementation of validated procedures in PN for WCM.
- The South Australian Railway Safety Regulator monitor the continued development towards feasible implementation of RailBAM and ensure that validated procedures for its use are implemented in both PN and the ARTC.

1 OVERVIEW

1.1 Location

Train 6WP2 derailed immediately west of the Bates² crossing loop approximately 951.6 track kilometres from Adelaide on the Trans Australian Railway (TAR) in South Australia. This section of line forms part of the standard gauge³ Defined Interstate Railway Network (DIRN).

The Australian Rail Track Corporation (ARTC) has responsibility for the management of 4,430 route kilometres of standard gauge interstate track mainly in South Australia, Victoria, and Western Australia⁴ including the sections Adelaide – Port Augusta – Kalgoorlie.

The ARTC was created after the Commonwealth and State Governments agreed in 1997 to one organisation being responsible for the selling of access to Railway Operators, management of the network, management of infrastructure maintenance, capital investment in the corridors, and the development of new business on the national interstate rail network.

The TAR was completed by the Commonwealth Railways in 1917 between Port Augusta and Kalgoorlie and was the first standard gauge railway in South Australia. The standardisation of the railway between Sydney and Perth was completed in 1970.

The railway consists of a bi-directional single line where opposing trains are regulated to pass safely around each other at short double track section crossing loops. Bates is situated between the Barton crossing loop 31 km to the east and the Oldeea crossing loop 51 km to the west and is one of 44 such crossing loops and sidings between Port Augusta and Kalgoorlie in Western Australia.

FIGURE 1: The isolated location of Bates crossing loop looking towards the east



2 Bates was named after Daisy M. Bates CBE who devoted her life to the welfare of aboriginals in the area.

3 Standard gauge – a measurement of 1435 mm between the inside rail faces.

4 ARTC has, since this investigation started, also assumed management of the DIRN in New South Wales.

The TAR passes through predominantly desert terrain on the edge of the Nullarbor Plain in some of the most remote and sparsely populated parts of southern Australia. There are no railway personnel stationed at these locations⁵. Train crew carry out the necessary procedures at crossing loops.

FIGURE 2: Location of Bates, South Australia



Map by the Australian Government – Geoscience Australia

1.2 The occurrence

The derailment of wagon number RKCX24 resulted from the failure of a Roller Bearing Unit (RBU) which was undetected during normal operations.

Wagon number RKCX24 was owned by PN. Its journey to Perth originated at Morandoo railway yard, Newcastle, New South Wales, on Thursday 6 November 2003. It formed part of train number 6NY3 which was operated by PN and departed at 2335 (eastern summer time). The train proceeded without incident to Wollongong, New South Wales and terminated at Whyalla, South Australia before amalgamating in part with train numbered 6WP2 destined for Perth. The train started its westbound journey from Whyalla on Sunday 9 November 2003.

The train operator of 6WP2 was PN which is Australia’s largest private rail freight operator carrying bulk freight, intermodal containers, specialised services such as express trains, and haulage of long-distance passenger trains. Built from the sale of two government rail corporations, PN has around 3,100 staff, 1,000 locomotives, and 10,200 wagons.

A number of checks and inspections were applied to trains 6NY3 and 6WP2 between Sydney and the location of the derailment at Bates. These included pre-departure inspections, roll-by visual inspections by PN and other train operators, and wayside detection systems.

⁵ The Code of Practice for the Defined Interstate Rail Network defines the term ‘location’ as, ‘The designated name used to describe a place on the railway.’

Train 6NY3 passed through wayside detection systems at Lara in Victoria, and Port Germein and Nectar Brook in South Australia. In each case the system did not detect any condition in the train requiring immediate attention.

On the morning of the derailment, a pre-departure inspection of train 6WP2 occurred at Port Augusta, South Australia, before departing for Perth. No defect was found during this examination.

In travelling 633 kilometres between Port Augusta and Bates, train 6WP2 met five opposing trains. The locations were Hesso, Bookaloo, Kultanaby, Ferguson, and Mount Christie. In the 12 hours leading up to the time of derailment of train 6WP2, three other trains passed through Bates.

Train 6WP2 was subject to a roll-by examination by the crew of Adelaide bound train 1LA6 at Ferguson three hours and 29 minutes before the derailment of wagon number RKCX24. There was no indication of any defects.

A crossing with Sydney bound train 7PS6 was made at Mount Christie one hour and 27 minutes before the derailment and was the last external inspection of 6WP2 undertaken before the occurrence at Bates. Train 6WP2 was stationary in the crossing loop at Mount Christie for this crossing. The deteriorating RBU was situated on the far-side; therefore an observation of the train in motion or the detection of an irregular RBU could not be made. The driver of 7PS6, with the locomotive side window open and travelling at about 40 km/h, did not see or smell anything of concern. This was reported to the crew of 6WP2 on the departure of 7PS6.

Train 6WP2 passed through Barton, the crossing location prior to Bates, at 2155 (central summer time) without incident. Bates was reached at 2222 where the train crew radioed a routine location and time report to Adelaide train control.

FIGURE 3: The remains of the journal after 'screwing' from the axle with the heat affected area of the surface marked as shown



Somewhere between Ferguson and Bates the RBU, on the right-hand side (in the direction of travel) leading axle of the trailing bogie of wagon number RKCX24, deteriorated to a serious level.

FIGURE 4: After coming to rest, the attitude of the wheel set and bogie side frame can be seen

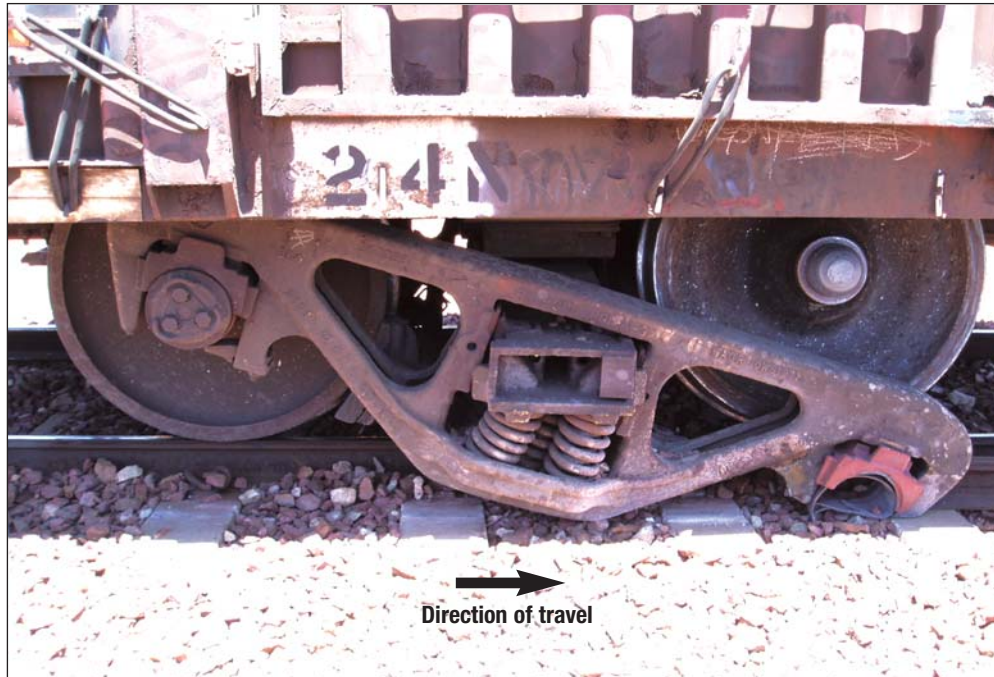

Note the conical shape brought about on the heat-affected axle by the failure of the RBU and journal

The earliest evidence in the disintegration of the RBU was found about 1,500 metres beyond the east-end crossing loop points at Bates, in the form of fragments of metal and grease. The friction induced heat had by this stage caused the portion of axle between the RBU and the wheel to become 'plastic'. The RBU and journal had finally seized to a point where it twisted or 'screwed' and separated from the axle. The journal came to rest on the side of the track, 44 metres from the first evidence of disintegration.

The disposition of wagon number RKCX24's trailing bogie did not alter immediately after the loss of the RBU and journal. About 180 metres on, the leading end bogie side frame dropped to the outside of the right hand rail.

As the train continued, the bogie side frame caused minor damage to the sleeper tops and deposited remnants of the destroyed RBU to the trackside. At this time, the right-hand wheel was in a raised attitude off the rail and lodged under the wagon floor while the left-hand wheel remained on its respective rail. The speed of the train when passing through Bates was 77 km/h.

For almost another 200 metres the train continued in this state before passing through the western end points. A destabilising effect on the wheel set had then occurred and in approximately 140 metres, the left-hand wheel dropped inside the rail and onto the sleepers.

About this time the second driver noticed in the side mirror what appeared to be a fire on a wagon further down the side of the train as it passed through the western end of Bates. The operating driver immediately started braking the train, steadily bringing it to a stop. The train came to rest in just over 1,000 metres from the point of this brake application.

FIGURE 5: A view of bogie from the opposite side. Evidence of the damaging effect on the sleepers can be seen on the wheel flange and tread



As the left-hand wheel continued to rotate it caused severe damage to approximately 2,100 concrete sleepers as well as left-hand rail fixings up to the final stopping location of the wagon. At some point, the dragging right-hand bogie frame had also collected a loose short piece of rail situated beside the track.

At 2225 the operating driver advised Adelaide train control of the incident and soon after provided supplementary advice of the extent of damage.

1.3 Personnel involved

Personnel involved directly with the running of train 6WP2 on the night of the occurrence were a crew of three locomotive drivers. The crew rotated in turn through the positions of operating driver, second driver, and one driver resting in the crew coach behind the locomotives.

A train controller from Adelaide train control centre regulated the passage of trains over the line to Kalgoorlie.

The personnel records of those immediately involved with the occurrence showed that they were considerably experienced and appropriately qualified in their respective positions of responsibility.

1.4 Injuries

No person was injured.

The occurrence was in a remote location of Australia and did not involve any other trains, including passenger trains.

The damage was wholly contained within the envelope of the wagons travelling well behind the locomotives and thus did not result in any conditions hazardous to the three-person train crew.

There was no report of post-incident stress or related conditions to the train crew or other personnel.

1.5 Medical and toxicology information

The driver and second driver operating the locomotive hauling the train were requested to undertake a breath test following the occurrence. The tests, administered by an officer of PN, resulted in a 'negative result' for both drivers.

1.6 Train information

1.6.1 Train 6WP2

Hauled by PN locomotives NR38 and NR101, the train consisted of 73 wagons weighing 4,612.34 tonnes⁶ and a total train length of 1,793.5 metres. The locomotives each weighed 132 tonnes. The lead locomotive was running off-line⁷ with only the second locomotive producing traction power.

The 73 wagons were mostly loaded with containers, some motor vehicles, and steel products. Wagon number RKCX24 was loaded, positioned 21st in the train, and was one of 24 steel carrying wagons immediately behind the locomotives.

1.6.2 Wagon RKCX24

The RKCX wagon class is of the open or gondola style construction with vertical sides and ends, a flat floor and an open top. The wagon is fitted with sidewall doors and may be fitted with a removable cover such as a tarpaulin. The wagon is also a 'steel products car' and is specially equipped for the transport of Merchant Bar⁸.

6 The weight of 4612.34 tonnes included the weight of one locomotive running off-line. The gross weight of the train was 4744.3 tonnes.

7 A locomotive is 'off-line' when its traction power has been isolated. The control of other locomotives in the consist from an off-line locomotive is still available.

8 Merchant Bar is steel available in a variety of general use types and forms as summarised: flat bar black, flat bar galvanised, angle black, angle galvanised, round black, round galvanised, and square bar.

FIGURE 6: RKCX wagon class



Table 1: RKCX wagon class details

Tare weight	23 tonnes
Length	14.9 metres
Max gross weight	80 tonnes
Capacity	57 tonnes
Max allowable speed	80 km/h
Number in class	68 wagons
Date built	1973
Use	Merchant Bar

1.6.3 Wagon axle mounted bearings

RBU's are fitted to the axle ends outside of each wheel. Each axle end of the RKCX class is fitted with two tapered roller bearings mounted opposite each other in a RBU in which all the bearing elements are combined into one self-contained assembly.

A roller bearing consists of four elements: two rings; the cage; and the rollers. The outer ring or cup of the RBU acts as the support and enclosure housing and seals are fitted to each end of the assembly for the retention of lubricant.

The RBU's are fitted over the cylindrical portion of the axle – the axle journal – and retained to the end face of the axle by an end cap. Mounting the inner ring with a press fit and then securing it with an end plate prevents rotation between the axle and RBU. This 'interference fit', prevents rotational creep between the inner ring and the axle. The RBU is then located and retained on the wagon bogie side frame pedestal by a bearing adaptor casting.

FIGURE 7: Cut away of the tapered RBU and journal similar to wagon RKCX24

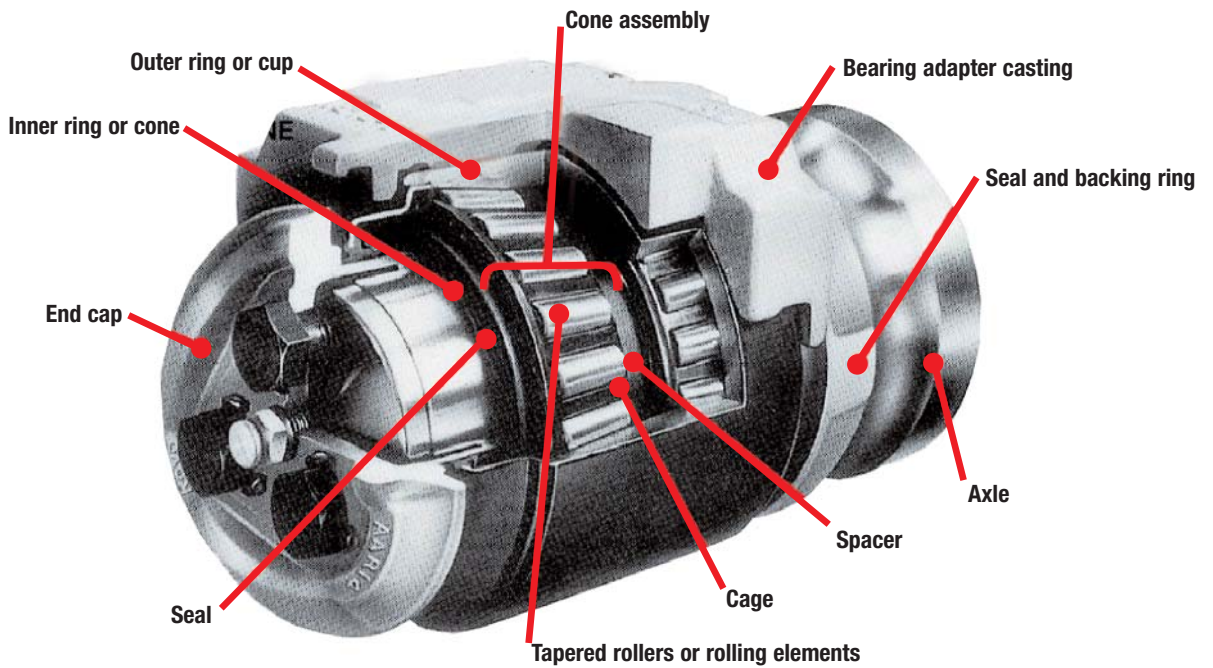
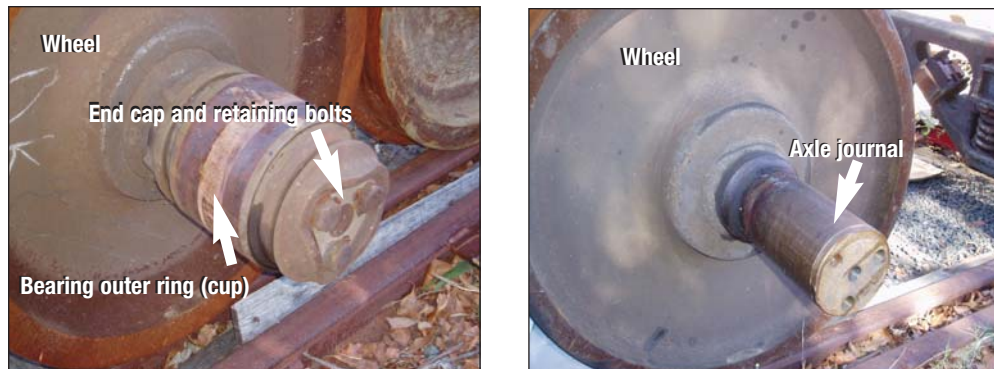

Photo by Koyo Seiko Co. Ltd., labelling by the ATSB

FIGURE 8: (Left) A RBU fitted to the axle journal of a wagon similar to the RKCX class (Right) The RBU removed and showing the axle journal



The advantages of tapered roller bearings include:

- a rolling motion with load bearing contact and positive roller alignment
- low friction from start and at all speeds
- ability to sustain large radial and thrust loads
- high reliability
- long intervals between re-lubrication
- easy installation and removal.

The RBU (numbered 305809) that failed in the occurrence was manufactured in 1996 and had been requalified (reconditioned) by September 2002.

In October 2002, work was carried out on the wheel set (R5D4S10970) that was to later fail at Bates. This included the replacement of both wheel discs (QXN02033412 and QXN02033409) and their associated RBUs (305809 and 305842 respectively). The company undertaking this work, MainTrain N.S.W. produced a Certificate of Compliance dated 17 October 2002. The wheel set was then held in storage for approximately eight months.

In May 2003 wagon RKCX24 received periodic examination including work on both bogies and the four wheel sets. It was at this time or very soon after in June 2003 that the stored wheel set (R5D4S10970) was fitted to the bogie (XCW0125).

The failure of the RBU (305809) occurred five months later and after 61,000 km of service.

1.7 Track infrastructure details

The ARTC was the accredited Railway Manager for the track at Bates. As the track infrastructure owner, the ARTC is responsible for the maintenance of this infrastructure. The ARTC had contracted this function to Transfield Services.

The track infrastructure at Bates is steel rail weighing 47 kilograms per metre secured to concrete sleepers with resilient fastenings, on ballast, and is typical of the standard of the TAR.

Transfield Maintenance document numbers TMI-6454-ML-0001, TMI-6454-ML-0079, TMI-6454-ML-0002, and TMI-6454-ML-0003 specify the ARTC requirements for track infrastructure inspection. The inspection regime consists of:

- routine 96 hour and one weekly patrol inspections
- track inspections (one monthly)
- main line detailed patrols/general inspections (three monthly)
- general inspections (12 monthly).

The Transfield Services Track Inspection & Assessment Report of 6 November 2003 for the track section Tarcoola – Cook, records that the track between Barton and Bates was inspected and found to have had no immediate issues.

There were no reports of temporary speed restrictions at the time of the derailment or conditions present that would have affected the operation of trains. Apart from derailment related damage, no evidence was apparent to indicate that a defect in the track had contributed to the derailment.

1.8 Loss or damage

The damage to the train was contained to the trailing bogie, designated XCW0125 of wagon number RKCX24. The bogie was later replaced and the wagon returned to service at Bates.

Approximately 1,275 metres of track sleepers were extensively damaged between the indicated track location of 726.439 km (634.439 km from Port Augusta) and the stopping location of wagon number RKCX24 in the train. This included rail securing clips and fittings. Damage to approximately 150 metres of rail was also recorded.

Repairs to the track infrastructure were carried out on the day following the occurrence.

A number of trains in addition to the derailed train 6WP2 at Bates were affected. These included four eastbound freight trains as far back as Kalgoorlie and two westbound freight trains in the Port Augusta area. One passenger train was affected. The operators of the *Indian Pacific* passenger train incurred cancellation costs and in some cases, the costs of using air transport for their passengers.

In all, eight trains incurred consequential delays of a combined total of 7,839 minutes. This included a delay of 1,476 minutes to train 6WP2 at Bates.

1.9 Train control information

A manual train authority system is used in the movement of trains on the TAR. This form of train order working is used by the train controllers located at ARTC's control centre at Mile End in Adelaide and the crews of trains to regulate the safe operation of the railway. Each train authority is voice communicated over open channel UHF radio using a combination of straight text and the spelling of critical words. UHF communications are recorded at the control centre.

The crossing and passing of trains is facilitated at numerous loops along the TAR. These locations are 'dark' and are not presented to the train controller in the form of an overview of signalling or each train's position.

At the time of the derailment, train 6WP2 was proceeding on a valid train authority and in accordance with procedures for the operation of the location of Bates.

1.10 Environmental factors

Records obtained from the Australian Government Bureau of Meteorology indicate that at the time of the derailment the weather in a wide area including Bates was fine with an overnight minimum temperature of 12 to 15 degrees Celsius and no rainfall. The records of interview provided by the locomotive crew of 6WP2 confirmed that the night was 'warm' and added that there was 'full moonlight and no wind.'

No evidence was found by the investigation to indicate environmental factors adverse to the operation of the railway at the time of the derailment.

1.11 Accident site information

The 'debris' from the failed RBU on wagon RKCX24 was first evident at a point approximately 1,810 metres east from the final stopping place of the wagon. A small deposit of grease and metal slivers was found at this location during the onsite phase of the investigation. Further deposits of grease and bearing remains were found along mostly the northern side of the track between approximately 1,675.6 metres and the wagon's stopping place.

At approximately 1,765.4 metres, the burnt remains of the journal and RBU were located. After having left the axle, marks indicated that it bounced for about five metres along the ground on the northern side of the track.

The first damage to the track infrastructure was observed approximately 161.3 metres after the remains of the burnt journal and RBU. This damage

consisted of intermittent rubbing and chipping along the northern outside surface of the sleepers. Apart from the commencement of chip marks of the eastern rail approximately 1,367.8 metres from the rear of RKCX24, any substantial damage of the track did not start until a point approximately 1,274.2 metres from RKCX24⁹. The rear of the train (approximately 1,304.8 metres to the rear of wagon RKCX24) came to a stop on this damaged track but did not derail.

The train was brought to a stop by a minimum of braking effort applied by the driver and this located the rear of train only metres outside the western end points at Bates. The stop made use of a 1 in 990 (0.1 %) ascending grade at Bates before coming to rest in a valley of 1 in 112 (0.89%) descending and 1 in 200/100 (0.5%/1.0%) ascending grades.

1.12 Details of fire

Although the temperatures generated in the RBU and journal of wagon RKCX24 leading up to the derailment were extreme, the conditions did not lead to any observable evidence of fire either on the train or to any area to the side of the track.

1.13 Dangerous goods

There were no releases of dangerous goods or toxic spillage of any kind as no dangerous goods were carried on train 6WP2.

⁹ This damage was observed from this point to the derailed wagon RKCX24.

2 KEY ISSUES

2.1 Introduction

The investigation examined the available evidence and considered a number of significant factors likely to have contributed to the derailment of train 6WP2 at Bates. As the accident occurred under suitable train operational and track infrastructure conditions, focus has been placed on three relevant areas. These are, the mechanical deficiencies associated with the RBU, the safety management systems in place to defend against RBU defects, and train operations procedures intended to limit the risk of mechanical failure leading to an accident.

The remains of the bogie were removed and forwarded to the Evans Deakin Industries Rail (EDI) workshops at Newport, Victoria where the Scientific Services Division of Australian Non-Destructive Testing Services Pty Ltd (NDT) made an examination and provided a metallurgical investigation report to the ATSB.

On arrival at NDT, one wheel set (axle 11221) had been complete and fitted to the bogie. The other wheel set (axle 11667) had been removed from the bogie and a number of bogie parts had been either lost or damaged during the derailment.

The failed RBU (number 305809) was examined to the maximum extent possible, given the destruction of the unit. The RBU (number 305842) at the opposite end of the axle to the failed unit was extensively examined for possible symptoms that would account for the failure.

The bogie had been partly disassembled at EDI Port Augusta, South Australia before arriving at Newport. Regrettably, RBU 305842 was stripped, cleaned, and inspected before the investigation team was able to make an examination. This resulted in an inability to measure the lateral clearance on the journal and to test the grease of the RBU.

2.2 Test and research details

Possible contributing factors to failure in a reconditioned RBU on an axle journal are: insufficient interference fit between journal diameter and inner ring bore when the RBU is fitted; lubrication problems during overhaul or in service; improper RBU assembly; and RBU seizure.

2.2.1 Failed RBU (305809)

RBU 305809 was destroyed in the occurrence with the majority of the components including rollers and a cage missing. One cage from the RBU, which was present, had the roller separators flattened in the failure. Details of the internal components of the RBU from the broken journal were limited due to the amount of damage sustained and the number of components missing.

The pattern of damage to the RBU components was considered to be consistent with one roller assembly being damaged more than the other.

Indications were that seal wear ring damage appeared at the inboard roller assembly and that this roller assembly was the first to have failed.

FIGURE 9: View of the failed RBU outer ring raceways in the overheated zone



The adapter from the failed RBU had been locked in the side frame as a result of the closing of the side frame pedestal legs. There were no external signs of uneven crown wear to indicate a misalignment and the adapter seat showed general even wear except for a 20 mm wide strip at the inner edge of both inner and outer seats.

There was heavy wear present on one side of the adapter on the inner surface. This indicated mechanical damage to the adapter resulting from the derailment. The outer face of the outbound thrust ridge had been broken. The damage was evidence of contact against a small diameter component such as the RBU cup end.

There was evidence that the failed RBU had experienced a loss of interference fit¹⁰ on the axle journal. This loss of interference fit led to the failure of the axle journal. A number of potential contributing factors to the loss of interference fit were determined by the investigation.

The evidence established by the examination found that failure of the roller assembly cage of the failed RBU led to the inner ring loss of interference fit on the axle journal. The cause of the cage failure could not be positively identified by NDT although it was determined that assembly of the RBU could have led to this failure. This was based on the failure early in the life of the RBU. The in service damage of the seals or seal failure was also considered to be possible contributing factors to cage failure.

2.2.2 Bearing cage – RBU 305809

There was evidence of rollers that had been displaced and were at right angles to their designed position. They had been embedded in the softened inner ring of one roller assembly. This was indicative of cage failure prior to the onset of overheating

¹⁰ The tight or shrink fit of the RBU onto the axle journal is an 'interference fit'. A loss of interference fit is where the RBU slips free on the journal preventing the correct rotation of the RBU.

of the roller assembly inner ring. The cage failure and the lack of spalling on the outer ring raceways suggested that the RBU failure was not due an initial loss of interference fit of either roller assembly.

FIGURE 10: Detail view of rollers embedded transversely in the inner ring raceway



The outer cage had broken and released the rollers. The broken cage was present but had been severely damaged in the failure and as a result of this, the cause of the broken cage could not be established. Some roller separators were missing and the remaining cage rolling separators had been flattened but were still attached to the cage. The flattening of the cage appeared to be a result of the RBU collapse rather than the cage elements rolling through the bearing. There was no evidence of rollers embedded in the intact inner ring. This indicated that the rollers had been displaced from the roller assembly prior to the softening of the inner ring from heat produced after loss of interference fit of the roller assembly inner ring.

The pattern of damage suggested that the cage failure had contributed to the loss of interference fit that was evident in the RBU inner rings. It was not possible to establish the cause of the inboard cage failure as the cage and most of the rollers were missing. There was also no clear indication of the cause of the cage failure evident on the remaining components of the failed RBU.

Cage distortion or cage breakage during reconditioning are unusual and do not normally occur in RBU assembly using appropriate tooling, suitable procedures, and experienced staff. Cage distortion or cage breakage during reconditioning normally produces failure early in service life of the RBU, although cage failure is more likely from roller replacement in the cage assembly¹¹. Since the failed RBU had been in service for only a comparatively short time, cage distortion or breakage during reconditioning is considered to be a potential cause of failure in this case. Installation of reconditioned roller assemblies with cage cracking from previous use

¹¹ According to Pacific National, this is rarely practiced in Australia.

is also a possible cause of failure in this instance as the failure occurred early in the service life of the RBU.

Cage manufacturing faults are unusual and associated failures would normally occur after a long service period. Typically, cage elements are rolled through the bearings after cage failure. There was no rolled cage material found but most of the cage from one roller assembly was lost in the failure. The remaining roller separators had been flattened and were still attached to the cage.

2.2.3 Interference fit

The wheel wear evident on the wheel set (1 – 2 mm) suggested that the wheels and therefore the roller assemblies had only had a small amount of use during the 1½ year interval since reconditioning. Insufficient interference fit at assembly was considered as a possibility, as loss of interference fit can often occur early in the service life of a RBU. However, there was no evidence of rollers indenting the softened inner rings in their normal orientation or spalling detected on the raceways on the outer ring which are known to occur in RBU failures due to a loss of interference fit of RBU inner rings. Loss of interference fit was not considered to be a contributing factor to the initial failure.

FIGURE 11: View of loss of interference fit on an inner ring bore



2.2.4 Bogie and wheel sets

The bogie had been damaged but appeared to have been in good condition prior to derailment. The mechanical damage to the bogie was limited to the vicinity of the broken axle journal. The broken components on the bogie were the result of instantaneous overload and were considered to have been a result of the derailment.

The bogie did not exhibit excessive gib¹² clearances and most of the damage was considered to be an effect of the derailment and not a cause. The derailment did not appear to have bent or damaged the bolster or side frames in the gib clearance area.

There was wear evident on the side frames and bolster when the bogie was inspected. Heavy wear was evident in the gib clearance area opposite the RBU failure but there were no signs of similar wear at other gib clearance areas. Measurements were taken at the top position at each side frame and the bolster gib clearances measured 25 mm. The wear limit for this type of bogie (50 ton SG Class C) at overhaul is 28 mm¹³.

FIGURE 12: General inboard view of the bogie gib area at opposite end to the failed RBU

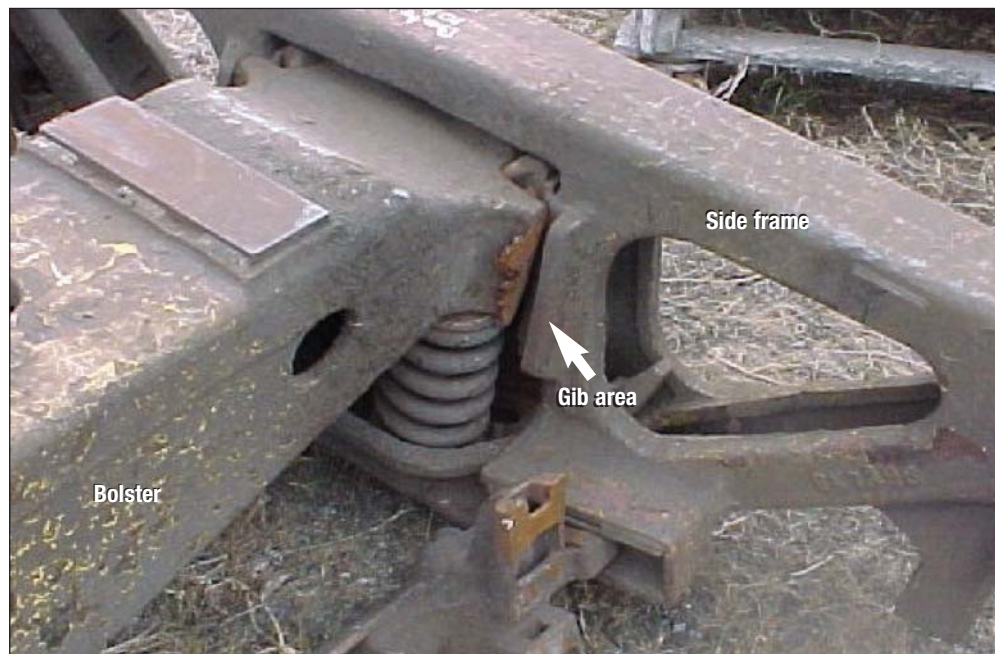

Both truss bars had been retained in the bogie, the closest to the failed axle (11667) had been bent adjacent to the brake head. This deformation had most likely occurred as a result of the derailment. The centre plate diameter on the bogie was close to specified size for new centre plates.

As there were no signs of similar wear elsewhere on the bogie, the wear can be considered to be a result of the journal failure at the opposite end of the wheel set. It was considered that the condition of the bogie had not contributed to the derailment.

¹² The 'gib' of a bogie is the contact area between the bolster and side frames.

¹³ Railways of Australia (ROA) Clause 24.2.5.2.

According to the wheel numbers on the failed wheel set axle, they had been fitted as new wheels at a wheel set overhaul in 2002. According to the numbers stamped on the wheel rims the wheels were also produced in 2002.

The wheels exhibited an almost new profile and were within specification on all dimensional checks made. The back-to-back wheel measurements for the wheel sets in the bogie were within Railways of Australia (ROA) specification requirements¹⁴.

Failed wheel set axle (11667) had no locking plates supplied for inspection and no axle stencil to indicate an overhaul date.

The other axle (11221) on the bogie had been overhauled during 2000 at Port Augusta according to its stencil – BI 6 00 PA. There were no markings of workshop inspection of the wheel set in the intervening period. The failed wheel set had been fitted with KOYO RBUs and met with Association of American Railroads (AAR) general practices for axles.

The wheels from the axle of the failed RBU were found to be in near new condition apart from the derailment damage to the treads. The wheels from the other axle of the bogie were found to have some wear, however the tread profiles of both wheel sets were within ROA specifications¹⁵.

From the information gathered it had been determined that there was no indication of any wheel tread irregularities or wheel set defects in the period leading up to the derailment, therefore wheel condition was not a contributing factor to this RBU failure.

2.2.5 Opposite end RBU (305842)

The intact axle journal on the failed wheel set was close to maximum permissible diameter. The failed wheel set (R5D4S10970 and axle number 11667) had been fitted with RBUs that were branded KOYO on the outer rings, this indicating that both ends of the axle had been fitted with RBUs of the same make.

The RBU from the opposite end from that which failed was numbered 305842.

As a result of earlier removal and examination by EDI at Port Augusta it was not possible to measure the lateral clearance of the RBU on the journal. Overhaul details stamped on the locking plate also were not available. Inspections of the locking plate tab positions and the end cap bolt tightness were unable to be performed and so the maximum press force to remove the RBU could not be measured.

RBU 305842 was found to be in generally good condition. However there was evidence of minor mechanical damage that appeared to be a result of excessive lateral movement when in service. This excessive lateral movement may have been a result of excessive lateral clearance within the RBU or a result of abnormal lateral loading due to the journal failure on the opposite end of the axle (305809).

There was light longitudinal scoring on the axle journal indicating that the roller assemblies of the RBU had interference fit on the journal prior to removal.

14 The ROA specification for back-to-back wheel measurements (Section 6.6) is 1357–1360mm.

15 Determined by using ROA Diagram 17–4–4 steel wheel gauge.

Measurements of the components showed that the average diameter of RBU 305842 was 131.86 mm at both the inboard and outboard seats. The tolerance for journals of class 'D' axles is 131.839 mm minimum to 131.864 mm maximum. The measured journal sizes were within the accepted range and close to maximum size.

The maximum average bore diameter permitted for KOYO and similar 5½ x 10 RBU assemblies is 131.8006 mm. The average bore diameter of the RBU assemblies was 132.63 mm (5.2215") for the roller assembly marked 12-601 at the centre of the inner ring. At the edges of the ring the bore size was within tolerance. For the roller assembly marked 12-602, the average bore diameter was 131.85 mm (5.203") at the centre of the inner ring. At the edges of the ring, the bore size was within tolerance. The measured bore diameters were greater than the maximum allowed for KOYO and similar 5½x 10 RBU assemblies at the centre of the inner rings.

The maximum bore out-of-round measurement permitted for KOYO and similar 5½x 10 RBU assemblies is 0.076 mm. At the centre of the inner ring the bore out-of-round measurement was 0.18 mm for the roller assembly 12-601 and 0.076 mm for the roller assembly 12-602. For roller assembly 12-601, the measurements taken exceeded the maximum out-of-round tolerance for class 'D' bearing bores. The bore of the roller assembly marked 12-602 was within the maximum out-of-round tolerance.

EDI Port Augusta also recorded other measurements relevant to RBU 305842. It was found that .092 inches of lateral movement was evident. The bearing journal radius was found to be slightly out of gauge at 5.1885 inch and 5.1880 inch. The radius was slightly oval and signs of rust on the radius were present.

The outboard seal wear ring was less damaged than the inboard seal wear ring. One seal case was more severely damaged than the other seal case and one roller assembly inner ring was damaged more than the other roller assembly inner ring.

RBU 305842 did not show any other evidence of internal component damage that could indicate the cause of the failure on the opposite axle journal.

The axle journal diameter was within specification and close to maximum permissible size. The examination however was unable to determine why the assembly bores were greater than specification at the centre and within specification at the edges. Likelihood exists that this condition may have been the result of impact from the derailment.

There were no signs of relative rotation or loss of interference fit detected on the roller assembly bores, which are known to occur with out of specification bores. The roller assembly appeared to rotate freely and there did not appear to be any indication of incorrect roller tracking on the raceway of the outer ring.

The components used met with AAR general practices for railway RBU overhaul. The components appeared to be intact with no signs of deformation as a result of the derailment.

The matching mechanical damage evident on the seal cases and roller assembly cages appeared to be a result of contact between the components. Under normal conditions with correctly assembled RBUs these components should be unable to touch. It is considered likely that the excessive lateral movement could be due to

excessive end play within the RBU or a result of abnormal lateral loading of the RBU due to journal failure at the opposite end of the axle.

Excessive lateral movement may be due to excessive end play within the intact RBU (305842) and could probably have been a contributing factor in the failure of RBU 305809. Excessive end play within one RBU can contribute to abnormal lateral loading of the cage in the opposite RBU. Excessive end play may result in lateral movement of the axle inducing uneven loads on the rollers of both RBUs. While it would not be expected that the opposing cages could sustain damage directly from excessive thrust loads, any damage incurred would most likely be consequential to the breakdown of the rollers and/or races.

2.2.6 Bearing care

A number of safety management standards in relation to the care of RBUs were in place and were examined during the investigation.

FreightCorp¹⁶ wheel set bogie standards, *Handling, Storage and Transportation of Freight Wheel sets and Bogies*, Standard number TRS 1320.01 published 12 April 2001 under a FreightCorp header was examined in the investigation.

The specification provided the minimum requirements for the handling, storage, and transportation of freight wheel sets and bogies with particular attention on the protection of the RBUs. In section 2.1 Wheel sets, 'Appropriate slings are to be used that do not damage bearing journal or wheel seats or axle barrels.' In addition, 'Forklift tynes are not to come into contact with any bearing journals, wheels seats, or bearing assemblies.' And, 'Forklift tynes shall not cause any bruising, scoring, or damage to the axle barrel.'

The storage of wheel sets is also covered: 'All wheel sets are to be stored on normal track (flange to flange) or in specially designed storage areas...Contact between the wheel flange and bearing cup/axle box housing is to be avoided at all times.'

The RBU manufacturer's (KOYO) *Handling Manual for Journal Bearings*, Section 3 *General Precautions - Handling*, recommend in 3.1.2 to: 'Handle the bearings with due care. Since the bearings provide improved hardness, the application of intensive shock due to rough handling can bring about brinelling or crack on the inner race or outer race.'

Section 3.2.3 *Mounting*, recommends: 'Check the axle journal and axle box for dimension and shape.' Further in Section 4.2 *Inspection*, 'The bearings have been manufactured with sophisticated accuracy, however, any inferior accuracy in the related component will not assure the desired performance. Since the accuracy of the axle can greatly influence the bearing, it needs to be checked sufficiently prior to mounting.'

16 FreightCorp was incorporated into Pacific National in 2002.

In 4.2.3 it states, ‘Inspection of the journal for diameter...Measure the axle journal diameter by using a micrometer or snap gauge.’

Although none was evident at the examination carried out by NDT, the track-side monitoring equipment recorded that the cup running surface of RBU 305809 developed a small surface fault (associated with spalling, water etching, brinelling, corrosion, and surface fragmentations) which developed rather quickly into a moderate cup fault. The wagon did not pass RailBAM regularly and therefore the fault degradation was not captured. When the wagon was not passing RailBAM, it was possible that the cup running surface degraded into a much larger spall, as the acoustic readings from the surface impacts had eroded away.

While the investigation could not determine the actual conditions of handling, storage, and transportation of the failed RBU before it entered service, inadequate bearing care is possible.

2.2.7 Assembling of RBU

Essential criteria should be applied when maintaining package unit type bearings.

Pacific National Wagon Manual Engineering Standard ESF-1550-G, dated 1 March 2001, prescribed the essential criteria to be applied when purchasing and maintaining package unit type bearings for ‘National Rail’ freight car bogies.

Section 1 *New Bearings*, requires that, ‘All bearing units shall have full AAR approval for interchange use...’

Section 2 *Mounting of Bearings on Axle Journal*, states, ‘Before mounting the bearings, the axle journal shall be checked and shall be within dimensional limits...’

Section 3 *Bearing Shop Inspection and Reconditioning*, provides the minimum and maximum bore diameters for each bearing inner ring. ‘The bore diameter of each bearing inner ring shall be checked with a certified micrometer or a pin or dial type gauge at three locations equally spaced around the circumference; the average of those three dimensions shall be within the limits prescribed. The dimensions for a type ‘D’ bearing are minimum 131.750 mm and maximum 131.775 mm.

It was likely that the components used in the failed RBU 305809 met with AAR general practices for RBU overhaul and these components were not considered to be a contributing factor to the failure. Both roller assemblies were destroyed in the failure and most of the assembly components were missing. The remaining roller assembly components and the outer ring were overheated and severely damaged in the failure. Both inner rings had lost interference fit on the axle journal. There were no signs of residual grease, spalling, RBU adapter misalignment, or metal to metal contact due to lubrication failure detected in the investigation.

The RBU was predominantly assembled from parts made by the same manufacturer and inappropriately matched component parts were not considered to be a likely contributing factor.

The other wheel set in the bogie was fitted with RBUs that were branded Brenco and FAG on the outer rings. RBUs from different manufacturers are not recommended to be fitted to the same axle under AAR general practices for axles. FAG bearings have however been manufactured by Brenco since 1989.

Incorrect assembly of RBUs or incorrect setting of end play leading to out of specification lateral clearance can contribute to lateral loading of cages and RBU seizure. There was a spacer missing after the RBU failure however this could have been lost in the failure itself or in an unlikely case, may have been missing since assembly. If the spacer was missing at assembly the roller assembly cages would have been subjected to lateral loading during installation. Lateral loading of the cages would also have occurred in service as the lateral clearance in the RBU would have been expected to be minimal. In this case there was no physical evidence found on the raceways of the inner or outer rings to support incorrect setting of end play. Lateral contact between rollers and cages can lead to excessive wear but since these components were lost or severely damaged in the failure it was not possible to assess them for abnormal wear.

2.2.8 Bearing lubrication

When lubrication problems occur in RBUs, overheating, smearing and welding of cages, rollers and races generally follow. In this case there was no evidence of metal to metal contact or metal transfer between raceways and rollers detected elsewhere while the rollers were still rotating. This suggested that the loss of lubricant had occurred after the inner rings had lost interference fit on the axle journal. From the evidence obtained in the investigation it appeared that the lubricant loss was more an effect of the failure rather than a primary cause.

2.2.9 Bearing seals

Seal failures due to manufacturing faults are unusual. But seal damage can occur in assembly, fitting, mechanical handling or in service. Seal failures can also occur as a result of over speed or overload conditions which can produce overheating of the seal rubber leading to hardening. Seal damage or failure can allow ingress of foreign material and egress of lubricant, which can contribute to RBU seizure that can lead to failure. The RBU seals were destroyed and the seal cases were severely damaged in the failure and this prevented the identification of seal damage as a contributing factor.

Mechanical damage can occur to seals in service as a result of bearing component failures. One seal case was severely damaged. The other seal was less damaged and appeared to have been damaged later in the failure. Both appeared to have been damaged against the adaptor thrust bridge ridges late in the failure.

2.2.10 Bearing adapter casting

A possible cause of seal damage in service is displacement of the RBU adapter. There were no clear signs of misalignment of the adapter detected on the crown or the side bearer pedestal that could have contributed to the RBU failure. The adapter appeared to have been correctly positioned on the RBU outer ring. The RBU outer ring was softened as a result of overheating and scored and indented from contact against the ballast so it is considered possible that minor evidence of misalignment on the RBU outer ring could have been obscured.

For the adapter to contribute to the RBU failure it would need to have been displaced to damage a seal or unevenly load the RBU. It would then need to have been realigned prior to the RBU failure, without leaving any clear signs of misalignment on the adaptor crown, side frame, or the RBU outer ring. Although this may be possible there was no evidence detected to support this.

The adapter seat from the RBU at the intact end of the axle showed even wear indicating that the adapter had been fitted properly prior to the failure. The location of the heavy bearing wear was consistent with the bogie twisting when the opposite end side frame dropped after the axle journal had failed and the wheel set with the intact RBU dropped to the track.

FIGURE 13: Detail inboard view of the adaptor casting at the failed RBU



The adapter from the failed end of the axle showed no signs of angular misalignment on the crown. The adapter seat showed predominantly even wear indicating that it had been fitted properly prior to the failure. While there was internal mechanical damage to the outer seat in the loaded zone of the adapter, the cause of this damage was not apparent as the seat and the RBU outer ring would normally be mated together at this point which should prevent damage at this location. The adapter seat was considered unlikely to have contributed to the failure of the RBU.

2.2.11 Rollingstock maintenance

As the failure of the RBU (305809) occurred at five months and 61,000 km of service, cage distortion or breakage during reconditioning is considered to be a potential cause of failure in this case.

An Equipment Work Order History for wagon RKCX24 was examined. It was found that a number of repairs and other services were made on the wagon between 10 November 2000 and 10 November 2003. Of these, work orders of interest to the investigation were:

Table 2: RKCX24 work order history items of interest

04/05/2001	COMPLETE 'B' EXAMINATION WAGON MAINTENANCE SCHEDULE
17/07/2002	INSPECT ONE BOGIE FOR CONDITION (Derailment check/post derailment) VEHICLE INSPECTION (Derailment Damage) (Derailment check/post derailment)
02/10/2002	INSPECT ONE BOGIE FOR CONDITION (Over date/Exam) VEHICLE INSPECTION (Over date/Exam)
17/10/2002	WHEEL SET R5D4S10970 FITTED WITH NEW DISCS AND BEARINGS
30/05/2003	REMOVE AND REPLACE SAME BOGIE REMOVE AND REPLACE ONE WHEEL SET (DEA bogie) (flange thin) COMPLETE 'A' EXAM WAGON MAINTENANCE SCHEDULE (Over date/Exam)

The wagon was involved in a minor slow speed derailment inside the OneSteel plant at Morandoo near Newcastle. The wagon was inspected and no significant repairs were required and was released on 17 July 2002. This occurrence was unlikely to have contributed to the derailment at Bates.

There was no indication in the records to suggest that wagon inspection or scheduled maintenance of wagon RKCX24 was a contributing factor in the derailment.

2.3 Monitoring of rollingstock condition¹⁷

2.3.1 Monitoring of rollingstock

National Rail Wagon Instruction WI 50-083, issue No.3 of 1 March 2001 describes the action to be taken by drivers, wagon maintainers, and terminal operators in the event a wagon trips hot bearing detection equipment or other circumstances when bearings are found to have been hot.

Section 6.2 *Drivers e) Screwed Journal* states, 'If an axle journal is screwed off the train shall be moved no further and recovery will be required.'

The related section 5.0 *Hot Box detection* of the *Pacific National Train Inspection Manual TIM 3A-10A* states:

Bearing failure most commonly leads to a 'hot box' condition. A hot box is overheating of the bearing/axle journal/axle box assembly usually resulting from lack of, or degradation of lubrication. If the hot box is not discovered and is allowed to continue unchecked, it could result in complete seizure and lead to a screwed journal resulting in derailment.

Although a latent fault condition may not have been apparent during the visual roll-bys prior to the derailment, the wheel management condition monitoring systems had detected deterioration in RBU condition on wagon RKCX24 between

¹⁷ Section 4.3 was largely based on the information provided by C Southern, ARTC. The ATSB acknowledges this contribution to the report.

July and November 2003. This data was made available for PN to plan and take appropriate action.

PN had not developed validated procedures or guidelines for the use of WCM or RailBAM systems.

The ARTC had established a series of parameters for a procedure which had been generated from studies on the limits of impacts for rollingstock on track. A procedure, *Engineering Process Procedure – 125*, had been in place from March 2003.

In these response procedures, a wheel impact alarm required the ARTC Train Transit Manager (TTM) to instruct the ARTC Train Controller that the suspected train is to be slowed and stopped at the next practical location. The train is to be slowed to a maximum speed of 65 km/h until the wagon is detached from the consist. The TTM is to inform the train operator of the alarm and advise that the affected vehicle will be detached.

In September 2003, PN's Rollingstock Maintenance section introduced a Failed Bearing Project Team. The team was created to review recent incidents and to develop a predictive system approach to failed bearings. A draft selection criteria had been developed to remove from service wagons that may fit a predetermined potential risk impact damage profile. As a result, from September 2003, over 200 wagons were identified as potential 'high risk' and were removed from service. The focus had been on the upper limits of the selection criteria however studies were also being undertaken for low level detections that potentially could lead to RBU failures.

The team had continued to identify potential high risk wagons using the impact detection selection criteria generated by the Wheel Impact Load Detector (WILD) detection system. Although in the early stages of development, the reduction of potential failed RBU risks resulting from impact faults appeared to be successful, a stronger focus for RailBAM acoustic detection was not undertaken until November 2003.

Information contained in the RailBAM data base listed over 5000 bearing passes that had a signal recorded¹⁸. The high number of recorded signals however reflected the developmental stage of RailBAM and the difficulty in providing a system approach to the selection of 'at risk' wagons or the ability to accurately define wagons in some order of priority. The project team was working closely with the ARTC and the RailBAM supplier Vipac to continually refine the acoustic selection process. PN had considered by June 2003, that increasing the use of track-side wheel bearing monitors, reviewing the approach to improve wheel bearing detection, and the review of wheel bearing standards to develop a standardised approach, were high priorities in their Major Hazard Action Plan.

In December 2003, what was believed to be the highest risk 200 RBUs to be progressively removed from service between December 2003 and January 2004, had been identified. The process led to some non-conformance issues being identified and weaknesses in defined standards being corrected. This in turn led to a reinforcing of existing maintenance standards and the introduction of more stringent instructions occurring throughout December 2003 and January 2004.

18 Note: Many of these passes are repeat readings of the same bearing but on a different date.

The team had identified four major causal factors that could result in a RBU failure – lubrication, design, wheel tread defect, and wheel fitment.

At the time of the Bates derailment, the industry had not finalised procedures to cover the track-side monitoring equipment. Nevertheless, PN had proactively taken action in removing high risk wagons from use. Wagon RKCX24 passed track-side monitoring equipment on 12 occasions but was not identified as posing a high risk.

2.3.2 Wheel condition monitoring systems

Teknis WCM had been installed on the ARTC controlled network. There are three locations:

- Lara in Victoria
- Port Germein in South Australia
- Parkeston in Western Australia.

The WCM provides train operators with the ability to accurately monitor the condition of wheel sets on rollingstock whilst in traffic, including:

- spalls, skids, and scale build up
- out of roundness
- multiple defects on a wheel tread.

Rail mounted sensors and load cells are arranged in crib arrays and measure the rail motion of the complete surface of the wheel tread. The acceleration measured at the rail sensor is translated in certain frequency domains into an impact force reading in Kilo Newtons by the signal processor located in the trackside enclosure.

The output of the wheel analysis is then normalised to the fully loaded wagon condition. The data is linked to the vehicle Automatic Equipment Identification (AEI) information read from the AEI tag reader and assigned to each wheel. The wheel condition data is forwarded from the three WCM sites to ARTC in Adelaide. The data is then forwarded to train operators.

The data collected by the WCM for wagon RKCX24 in the period January 2003 to November 2003 has been plotted to produce a graph in figure 14. This is a histogram plot of the impact force generated by the wheel tread defect at the wheel to rail interface (which has been normalised to a fully loaded wagon against a clean new wheel tread). The polar plot in the bottom left of the figure is the 'relative position of the wheel set impacts' and is a comparison of the wheel defect for both the left and right wheel for that wheel set.

FIGURE 14: WCM Fault Vehicle transit history graph for wagon RKCX24

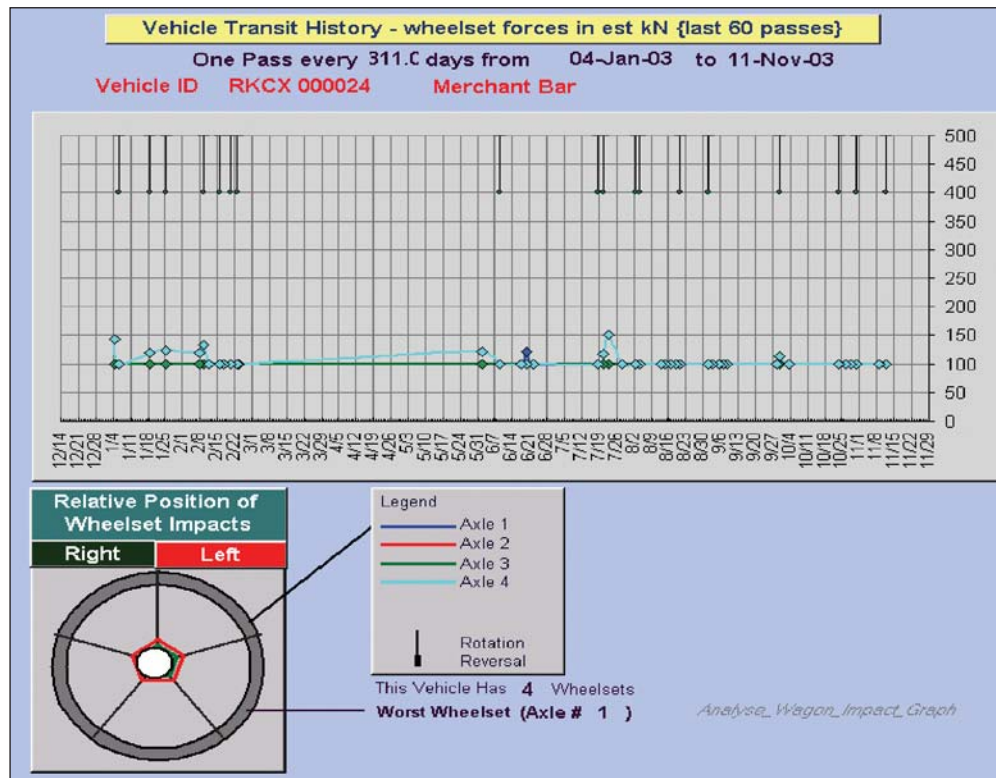

This histogram plot of the force generated by the wheel tread defect at the wheel rail interface has been normalised to a fully loaded wagon against a clean new wheel tread. The polar plot in the bottom left is the relative position of the wheel set impacts, a comparison of the wheel defect for both the left and right wheel for that wheel set (Graph by the ARTC).

There was no indication of any wheel tread irregularities or tread defects in the period leading up to the derailment.

One further electronic wayside system is in place¹⁹. A WILD unit had been installed at Metford in the Hunter Valley of New South Wales. Although train 6WP2 originated in the Newcastle area, wagon RKCX24 did not pass this detector.

2.3.3 Rail bearing acoustic monitor

A Vipac RailBAM had been installed at Nectar Brook in South Australia in June 2001. This monitor is a track-side device for the purpose of detecting a fault condition in the bearings of train wheels. This installation on ARTC track was being used but was being fine-tuned by Vipac, ARTC, and railway operators. Bearing defects have, however, been clearly identified with no false readings to date.

RailBAM is a preventative detection system rather than a reactive system such as a hot bearing detector. The RailBAM is designed to give train operators warning of a poorly performing rollingstock bearing before it leads to failure and causes interruption to the normal operation of the railway.

The system consists of two acoustic sensors, one on each side of the track. As each wheel axle and RBU of a train passes the system it detects and processes the 'signatures'²⁰ of each RBU. The acoustic sensor array employs beam forming and parabolic reflectors to focus in on individual wheel bearings. Optical wheel

¹⁹ The device, although on the DIRN, was outside the control of ARTC.

²⁰ Each noise is analysed and broken down into frequency orders.

detectors are employed to synchronise wheel and axle position to the acoustic measurements and the wagon identifying AEI tags. Each type of fault produces characteristic signatures, which are known, and the type of fault and severity of the fault is then determined from the spectra generated by that RBU fault. The information is sent to a central bearing condition trending database and can then be accessed on a web site by railway operators so that appropriate action such as wagon maintenance can be planned.

ARTC captured data relevant to wagon RKCX24 leading up to the day before the derailment. The severity and type of the RBU fault has been predetermined from tests conducted against bearings removed from service and during the calibration trials prior to the system being commissioned. Bearing faults are ranked by the system in three separate categories:

Table 3: RailBAM bearing faults ranking and categories

<i>RailBAM bearing fault type</i>	<i>RailBAM notation</i>
1. Rolling element	1, 2, 3, 4
2. Looseness and Fretting	(1), (2), (3), (4)
3. Noisy (Due to wheel rail interface, but often masking the bearing fault)	Noisy 1, Noisy 2, Noisy 3, Noisy 4

The RailBAM had been developed and designed to detect and report faults on rollingstock wheels whilst in traffic.

The system is not capable of picking up all initiators of RBU failure, such as loss of lubrication or lubrication contamination.

Rolling element faults are associated with ball pass frequencies for the inner and outer raceways and the roller elements. The readings stem from faults on the running surfaces including the following:

- spalling²¹, corrosion or etching²² on the cones, cups, and rollers
- brinelling and indentations²³
- loose components, fretting and loss of clamp force.²⁴

Looseness and fretting faults occur at the '1x' order. For example, the noise is continuous throughout the revolution of the wheel, or only occurs once per revolution of the wheel. Where a bracket is placed about the reading it relates to a fault, which is predominantly consisting of looseness, back face wear, seal wear or the seal has folded under, and loss of clamp or fretting readings. Some external factors can also produce looseness or fretting reading. These are: wheel flats; equipment rubbing on the wheel set or axle; new seals breaking in; and poor

21 Spalling is a form of wear. Particles fracture from a surface in the form of metal flakes and are the result of surface fatigue.

22 Corrosion is the decay and loss of a metal due to a chemical reaction between the metal and its environment.

23 Brinelling occurs when loads exceed the elastic limit of the ring material and is caused by any static overload or severe impact. Brinell marks show as indentations in the raceways which increase bearing vibration (noise).

24 Fretting is the generation of fine metal particles which oxidize. This material is abrasive and will aggravate the looseness allowing considerable movement of the inner or outer ring.

tracking wheel sets which may be flanging (these can often be determined by examining the wagon or closely listening to the noise generated by the RBU). Noisy faults are those that are not in a fixed fault band (i.e. due to flanging, squealing, and some rolling noise). A ‘noisy’ component can mask other RBU faults.

The level of the reading by severity (level 1 being the highest) and suggested actions for the RailBAM system are as follows:

Table 4: Looseness and fretting faults ranking and recommended actions

<i>Notation</i>	<i>Bearing Fault Type</i>
Level 1	Recommended for removal, unless clarified as external causing factors.
Level 2	Medium level faults - either remove depending on the growth rate or continue to monitor more regimentally, depending on further severity.
Level 3	Very minor - monitor for growth.
Level 4	Negligible fault reading.

The RailBAM system recorded the passing of wagon RKCX24 in various trains on at least 12 separate occasions in the months leading up to 9 November 2003. The last recording prior to the derailment was at 1932 hours on Saturday 8 November 2003. The RailBAM system had given the wheel set and failed RBU the position identification as ‘3A’:

Table 5: The severity level for RBU 3A from the RBU defect for the acoustic bearing passes registered from the initial reading

<i>Date</i>	<i>Time</i>	<i>Severity</i>
18 July 2003	15:40 hrs	Level 3
20 July 2003	19:18 hrs	Level 3
28 July 2003	03:55 hrs	Level 2
04 August 2003	12:34 hrs	Level 3
12 August 2003	21:08 hrs	Level 2
18 August 2003	18:27 hrs	Level 3
01 September 2003	02:29 hrs	Level 2
06 September 2003	22:57 hrs	Level 2
28 September 2003	13:04 hrs	Level 2
23 October 2003	20:49 hrs	Level 2
30 October 2003	11:54 hrs	Level 3
08 November 2003	19:32 hrs	Level 3

From the data gathered by the ARTC, an examination of the results was undertaken. The fault levels had also been further broken down by the ARTC to represent Low, Medium, and High fault levels. These fault levels were based on pull down results and commissioning results, and were individually tailored to each fault type. Fault levels for cone, cup, looseness, and rollers had been depicted, as the RBU had elements of these faults in both the failed RBU and the opposite RBU in position 3B.

2.3.4 Wheel condition monitor and bearing acoustic monitor combined analysis

From the track-side monitoring data, the strength of the fault appeared to be direction dependent, that is, in one direction past the system it gave a stronger reading than in the other direction. If the AEI tag 'A' was read first, then the wagon was travelling in a positive direction. If AEI tag 'B' was read first, then the wagon was travelling in a negative (reverse) direction. By aligning the RailBAM readings with that of the WILD weight loadings, and the direction in which the wagon was travelling, the higher readings tended to align with the higher wagon loads and the negative Revolutions Per Minute (RPM) of the RBU.

These higher fault readings may have been attributed to loading in the bearing loading zone. The location in the loading zone may have altered as the cup may have rotated in the adaptor when passing the system and therefore moving the location of the cup fault out of the loading zone.

Table 6: Wheel condition monitor/bearing acoustic monitor combined and loading/direction readings

<i>Date (2003)</i>	<i>Time</i>	<i>WCM Train speed average</i>	<i>WCM wagon load</i>	<i>RAILBAM severity</i>	<i>RBU RPM</i>	<i>Higher fault reading</i>
18 Jul	15:19	78	69.48	3	Positive	No
20 Jul	19:46	77	71.02	3	Positive	No
28 Jul	03:34	75	65.79	2	Negative	Yes
04 Aug	13:02	79	20.94	3	Positive	No
12 Aug	20:48	78	67.56	2	Negative	Yes
18 Aug	18:56	79	22.91	3	Positive	No
01 Sept	02:07	72	66.18	2	Negative	Yes
06 Sept	23:27	74	24.93	2	Negative	Yes
28 Sept	12:41	73	73.94	2	Negative	Yes
23 Oct	20:30	79	64.84	2	Negative	Yes
30 Oct	12:16	80	21.53	3	Positive	No
08 Nov	19:05	77	68.80	3	Positive	No

As a comparison, the reading for the opposite RBU on the same axle at the opposite side of the wagon, '3B,' was provided by the ARTC. The spectra and fault strength readings for the opposite RBU '3B' are provided in Appendix 6.5.

Clear acoustic fault signatures for both the failed and opposite RBU identified multiple faults present in the months leading up to the failure.

Similar cup faults on the running surfaces were detected within a week of one another of approximately the same severity for both the failed and opposite RBU (the lag in reading may be due to the position of the cup fault in the loading zone i.e. different positions in the adaptor as bearings do not creep at the same rate). As both RBUs presented a similar cup fault, it is likely that this may have been generated at the same time. For this to occur, the fault initiator is most likely one of the following:

- water ingress when a wheel set is left in storage (as water generally collects and corrodes in the same location within the RBU)

- mishandling of the wheel set prior to installation in the wagon – where an impact may have caused brinelling on the running surface of the cup as the rollers indented into the cup surface
- an impact load on the wagon as it was loaded – however this would most likely have caused similar faults on the RBUs on other wheel sets.

From the data gathered, the examination of the results for RKCX24 was as follows:

Table 7: Wheel condition monitor/bearing acoustic monitor analysis of results

<i>Date (2003)</i>	<i>Analysis results</i>
18 July	No fault recorded
20 July	Very minor cup fault
28 July	Minor cup fault
04 August	Very minor cup fault
12 August	Minor cup fault with initiation of minor roller defects (possible roller indentations or debris on roller)
18 August	Minor cup fault and start of minor cone fault
01 September	Minor cup fault and start of minor cone fault
06 September	Minor cone fault and no cup fault detected (most likely due to the movement of the cup in the adaptor or changes in the shape of the cup fault)
28 September	Medium to high cup fault - rapid growing cup fault
23 October	Rapid changes in the fault (moderate cone fault with minor roller faults, and no cup readings)
30 October	Small cup fault
08 November	Medium cup, cone, and roller faults

When the RBU was running with this cup fault, debris from the fatiguing area had become distributed in the lubrication and the continual impacts from the defect surface had resulted in further faults being developed within the RBU on both the cone running surfaces and the roller elements. As the RBU running surface developed into a large spall, the roller element contact in the loading zone had not created as large an impact force as it did initially with the smaller surface defects on the running surface. This meant that the RBU may have ‘spalled out’ over a large area, minimising the surface contact area to produce an acoustic signal.

The recorded faults in the opposite RBU were variable and this was most likely due to changing surface characteristics of the faults within the RBU and rotational creep within the RBU adaptor casting. This allowed the fault to move out of the loading zone.

While information gathered by the wayside detection systems located on the ARTC network indicate that the RBU was in a deteriorating state, the wheel tread condition was in a good smooth condition prior to the RBU failure and cannot be considered a contributing factor to the occurrence.

2.3.5 History of similar bearing incidents

According to PN, 19 RBUs had failed in service in the 2002 calendar year and 16 RBUs had failed in 2003. The ARTC and the South Australian Railway Safety Regulator provided comparable figures. Over 50 per cent of the causes for PN RBU failures could not be determined. The failures for 2003 were shown as:

Table 8: PN failed RBUs 2003

<i>Possible cause</i>	<i>Number of incidents</i>
Track Related	0
Lubrication	1
Fitment & Storage	1
Design	2
Wheel Related	3
Inconclusive	9

2.4 Operations

2.4.1 Train examination and inspection

Wagon RKCX24 proceeded without incident from Newcastle to South Australia immediately prior to the date of the occurrence.

The necessary pre-departure and enroute roll-by checks were carried out including a train examination at Port Augusta when the wagon continued in train number 6WP2.

ARTC Network Interface Coordination Plan document number TA02, issue 2.2, 30 June 2003 provides Section 20 *Roll-By Inspections* read in part, that:

Arrangements for roll-by inspections shall be the responsibility of the train operator...

Qualified workers shall carry out roll-by inspections whenever possible...safe and practicable to do so...

Where infrastructure and ground conditions allow it to be done safely...train crews conducting crossings or passing during darkness, one crew member shall remain on the locomotive and utilise the head light to observe that side...

Pacific National/National Rail procedures were also in place to guide the action to be taken by drivers in the event of a wagon tripping hot bearing detection equipment or other circumstances when bearings are found to have been hot. The procedures in part highlight that a bearing failure most commonly leads to a 'hot box' condition. If the hot box is not discovered and is allowed to continue unchecked, it could result in complete seizure and lead to a screwed journal resulting in derailment. Finally, if an axle journal is screwed off, the train shall be moved no further and recovery will be required.

The PN *General Requirements of the Train Inspection* section 4.0 *Passing Roll-by Inspections*, TIM 1-4, 5 November 1999, provides for the conduct of roll-by inspections:

Wherever practical, any suitably qualified person should conduct a Passing Roll-by inspection on any train passing their location. These inspections are usually

conducted en route at crossing loops, sidings, signal boxes etc by train crews or other Rail Authority/Track Owner employees. They are often conducted at mainline speeds and, as such, are usually only able to detect gross train or loading defects. They are important however, as a means of confirming overall train condition and integrity and condition to train crews. When admitting trains to crossing locations, a roll-by inspection of the train is to be performed by the locomotive drivers, wherever it is safe and practical to do so:

- when crossing or passing trains
- after being relieved en route or in a yard
- at crew change and depot locations, and
- when arriving or departing trains into or from any yard where no qualified employee is present.

At crossing loops and where infrastructure arrangements and/or ground conditions allow it to be done safely, one crew member is to be positioned in line with the locomotive on the opposite side of the main running line at a safe distance from the consist.

Train 6WP2 crossed five opposing trains between Port Augusta and Mount Christie with at least five train crews, as well as the crew on train 6WP2 itself, being in a position to observe the passage of RKCX24.

From the evidence taken, indications are that the necessary examinations were carried out and no obvious signs of a defect were observed on each occasion.

Given the evidence, it is likely that somewhere between Ferguson and Bates the wheel bearing deteriorated with final disintegration occurring when passing through Bates.

It was not until arrival at Bates that the hot bearing on wagon RKCX24 became evident to the train crew. It is likely that its collapse developed rapidly in the latter part of the three hours and 29 minutes from Ferguson.

2.4.2 Train operation

ARTC Network Interface Coordination Plan document number TA02, issue 2, released 5 March 2001, list the maximum allowable speeds and the posted speeds limits for all track sections including Barton to Bates. Apart from a short section of 100 km/h between kilometre posts 702.120 and 702.900, the posted speed maximum was 80 km/h.

Pacific National's Data for Train Operations, dated 17 February 2004, required in the document's *General Conditions* that the RKCX class of wagon was not to exceed a speed of 80 km/h under any circumstances.

The leading locomotive of train 6WP2, NR38, was equipped with a functioning Westinghouse Air Brake Company (WABCO) railway electronic data recorder. The data included a record of the locomotive operation leading up to the derailment and the subsequent stopping of the train.

For a distance of 55 kilometres²⁵ to the point of derailment, the information showed that the speed of the train was maintained below the maximum allowable train

²⁵ Extent of the information provided on the data logger read-out.

speed of 80 km/h. While the speed management of the train oscillated in accord with the terrain, the air brakes were not used over this period until the final stop after the detection of the derailed wagon.

The power controller had been steadily decreased from full power (RUN 8) to IDLE over approximately two minutes to allow the train to coast for over one and a half kilometres through Bates. Immediately prior to the wagon derailing, the speed of the train was recorded as 77 km/h with the power controller in IDLE.

At the apparent detection of the failed RBU, a minimum train brake application of about 55 kilopascals (brake pipe reduction) was made and at the same time the power controller was advanced to minimum power (RUN 1). The driver maintained these control settings until the train came to a stop approximately one and a half minutes later. On stopping, the power controller was closed to IDLE and a further train brake application of about 49 kilopascals was made before releasing the brake and applying the locomotive independent air brake. The driver's actions were commensurate with the situation and the procedures by applying minimum braking effort and a minimum amount of traction power to bring the train to a stop.

The operation of the train was in accordance with procedures and was not considered to be a contributing factor of the derailment.

3 CONCLUSIONS

3.1 Cause of derailment

Based on the evidence, it is concluded that train 6WP2 derailed due to the failure of a RBU (3A) on Wagon RKCX24. Friction induced heat from the seized RBU caused the axle between the RBU and the wheel to become 'plastic' to the point where the axle twisted from the RBU.

3.2 Findings

1. Scheduled workshop maintenance was carried out on wagon RKCX24 and did not contribute to the derailment.
2. The bogie gib clearances, wheel tread dimensions, and wheel set back to back measurements were within specification. The condition of the bogie and wheel sets was considered unlikely to have contributed to the RBU failure.
3. There was no evidence that a manufacturing fault in the RBU contributed to the derailment.
4. Pre-departure and en-route train inspections appeared to have been carried out appropriately. Although the failed RBU developed its fault over a period of time, no signs of imminent failure were apparent to those undertaking the inspections.
5. The train crew of train 6WP2 were operating the train within set speed limits. The crew acted appropriately when the RBU failure had been detected and brought the train to a stop without aggravating the derailed wagon and causing any further damage.
6. There was no evidence to indicate that any defect in the track infrastructure had contributed to the derailment.
7. The investigation could not determine if the RBU had been mishandled prior to use or that a link between the detected cup faults and bearing failure existed.

3.3 Contributing factors

1. From the investigation evidence it was found that the most likely cause of the RBU failure was roller assembly cage failure leading to inner ring loss of interference fit on the axle journal.
2. The workshop assembling and fitting of the RBU to the axle journal was a possible contributing factor to cage failure based on the relatively short service life of the unit.
3. There was some evidence of lateral movement, due to excessive end-play, within the intact RBU at the opposite end of the axle to the failed RBU. Such movement could probably have contributed to the failure of RBU 305809 at the opposite end of the axle.

4. Probable water ingress from less than optimum storage of the RBU was suggested by evidence, as detected by RailBAM.
5. The radius of RBU 305842 (the opposite end of the axle to the failed RBU) was out of specification and displayed signs of rust.
6. Validated procedures for RailBAM to provide guidelines for its use had not been in place by PN or the ARTC.
7. The interim criteria adopted by PN for removing high risk wagons, based on the RailBAM and WCM data, did not identify wagon RKCX24 as having a reading sufficiently serious to remove it from service.

4 SAFETY ACTIONS

4.1 Actions taken

Following the accident on 9 November 2003, at Bates, safety actions corresponding with the evidence determined had been initiated by Pacific National.

1. Pacific National released Rollingstock Maintenance Notice RSMN No.33/03: 'In Motion' Detection Systems Management dated 21 November 2003. The notice was introduced with, 'Issue: PN has embarked on wheel management condition monitoring, which falls into two categories, WILD and RailBAM. Recent investigations into 'in transit' bearing failures has indicated some wheels have had wheel tread defects prior to bearing failing 'in servic'. Also, some wheels have indicated potential faults prior to the bearing failing in service.

The notice corrects the previous lack of procedures for the use of condition monitoring systems and sets out the requirements for wagon detection, decision criteria, and actions for wheel removal from service.

The document had an expiry date of 30 June 2004.

2. Pacific National released Rollingstock Maintenance Notice RSMN No.31/03: Transportation, Handling and Storage of Wheel sets dated 19 November 2003. This notice was introduced with, 'Issue: Recent investigations into in transit' bearing failures has indicated in some instances wheels prior to being fitted to wagons have not been transported, handled or stored in a manner that maintains the sound integrity of the wheel bearings, seals and associated components.

The notice provides instruction on the sound handling of the vulnerable components of wheel sets such as bearings.

3. On Friday 14 November 2003 an internal Pacific National e-mail was issued instructing that, 'As per our discussion could you please organise to have one of your qualified staff inspect approximately 63 wheel sets and determine if the bearings and wheel sets are safe to be fitted to operational wagons. Some of the wheel sets may have been stowed in the weather for long periods of time. If there are any wheel sets that are doubtful in any way I would prefer you to return them for bearing overhaul.'

4.2 Recommendations

As a result of its investigation, the ATSB makes the following recommendations with the intention of improving railway operational safety and associated safety management systems by overcoming shortfalls identified. Rather than provide prescriptive solutions, these recommendations are designed to guide the interested parties on what situations need to be considered. Recommendations should not be seen as a mechanism to apportion blame or liability. Recommendations are directed to those agencies that should be best able to give effect to the safety enhancement intent of the recommendations, and are not, therefore, necessarily reflective of deficiencies within those agencies.

4.2.1 Pacific National

RR20050003

The ATSB recommends that Pacific National undertake a review and implementation of remedial action as required of workshop processes for the care and fitment of bearings to make sure that appropriate measures are in place to reduce the risk of subsequent cage related failure.

RR20050004

The ATSB recommends that Pacific National undertake a review and implementation of remedial action as required of the storage, transportation, and handling of bearings to make sure that appropriate measures are in place to reduce the risk of accidental damage, particularly with regard to stored RBUs fitted to wheel sets.

RR20050005

The ATSB recommends that Pacific National undertake a review and implement remedial action as required of the refurbishment and assembly of bearings to make sure that:

- a) appropriate measures are in place to reduce the risk of accidental damage to components
- b) reconditioned roller assemblies are appropriately inspected when installed
- c) bearing bore sizes are satisfactory at the time of overhaul. (Desirably the method of measurement should be assessed to determine if it could adequately differentiate between diameters at the outer edges of the inner rim compared with the centre of the ring).
- d) journal diameters are satisfactory at the time of overhaul
- e) bench end play measurements at bearing re-qualification are examined to make sure that the measurements are within specification and lateral end play on installation is within specification.

RR20050006

The ATSB recommends that Pacific National further develop and validate their procedure for the use of Wheel Condition Monitoring systems. The procedure should include but not be limited to the following:

- a) identification of limiting factors and circumstances for the withdrawal of wagons from service when a fault or number of developing fault readings has been detected
- b) formalisation of the actions to make sure that faults detected are acted on in a specified time
- c) formalisation of the actions by train crews and others when faults detected en-route are advised by the Australian Rail Track Corporation.

RR20050007

The ATSB recommends that Pacific National continue their utilisation of Bearing Acoustic Monitoring systems with a view to improving the application of the information provided as soon as practicable and in line with their Major Hazard Action Plan.

RR20050008

The ATSB recommends that Pacific National develop and validate a procedure for the use of Bearing Acoustic Monitoring systems. The procedure should include but not be limited to the following:

- a) identification of limiting factors and circumstances for the withdrawal of wagons from service when a fault or number of developing fault readings has been detected
- b) formalisation of the actions to make sure that faults detected are acted on in a specified time
- c) formalisation of the actions by train crews and others when faults detected en-route are advised by the Australian Rail Track Corporation.

4.2.2 South Australian Railway Safety Regulator**RR20050009**

The ATSB recommends that the South Australian Railway Safety Regulator monitor the implementation of validated procedures in Pacific National for the use of Wheel Impact Load Detection System/Wheel Condition Monitoring systems.

RR20050010

The ATSB recommends that the South Australian Railway Safety Regulator monitor the continued development towards feasible implementation of Bearing Acoustic Monitoring systems and ensure that validated procedures for its use are implemented in both Pacific National and the Australian Rail Track Corporation.

4.2.3 Australian Rail Track Corporation**RR20050011**

The ATSB recommends that the Australian Rail Track Corporation develop and validate a procedure for the use of Bearing Acoustic Monitoring systems. The procedure should include but not be limited to the following:

- a) identification of limiting factors and circumstances for the withdrawal of wagons from service when a fault or number of developing fault readings has been detected
- b) formalisation of the actions to make sure that faults detected are acted on in a specified time
- c) formalisation of the actions when faults are detected en-route and operators are advised by the Australian Rail Track Corporation.

5 SUBMISSIONS

Section 26, Division 2, and Part 4 of the Transport Safety Investigation Act 2003, requires that the Executive Director may provide a draft report, on a confidential basis, to any person whom the Executive Director considers appropriate, for the purposes of:

- allowing the person to make submissions to the Executive Director about the draft; or
- giving the person advance notice of the likely form of the published report.

The final draft of this report was provided for comment to the following directly involved parties:

- i. Pacific National
- ii. Australian Rail Track Corporation
- iii. South Australian Railway Safety Regulator.

Consideration was given to each comment of the submissions received and appropriate adjustments have been incorporated into this report.

6 APPENDICES

6.1 Bearing, bogie, and wheel component details

FIGURE 15. Derailed wagon RKCX24, bogie number XCW0125 configuration, and component serial numbering

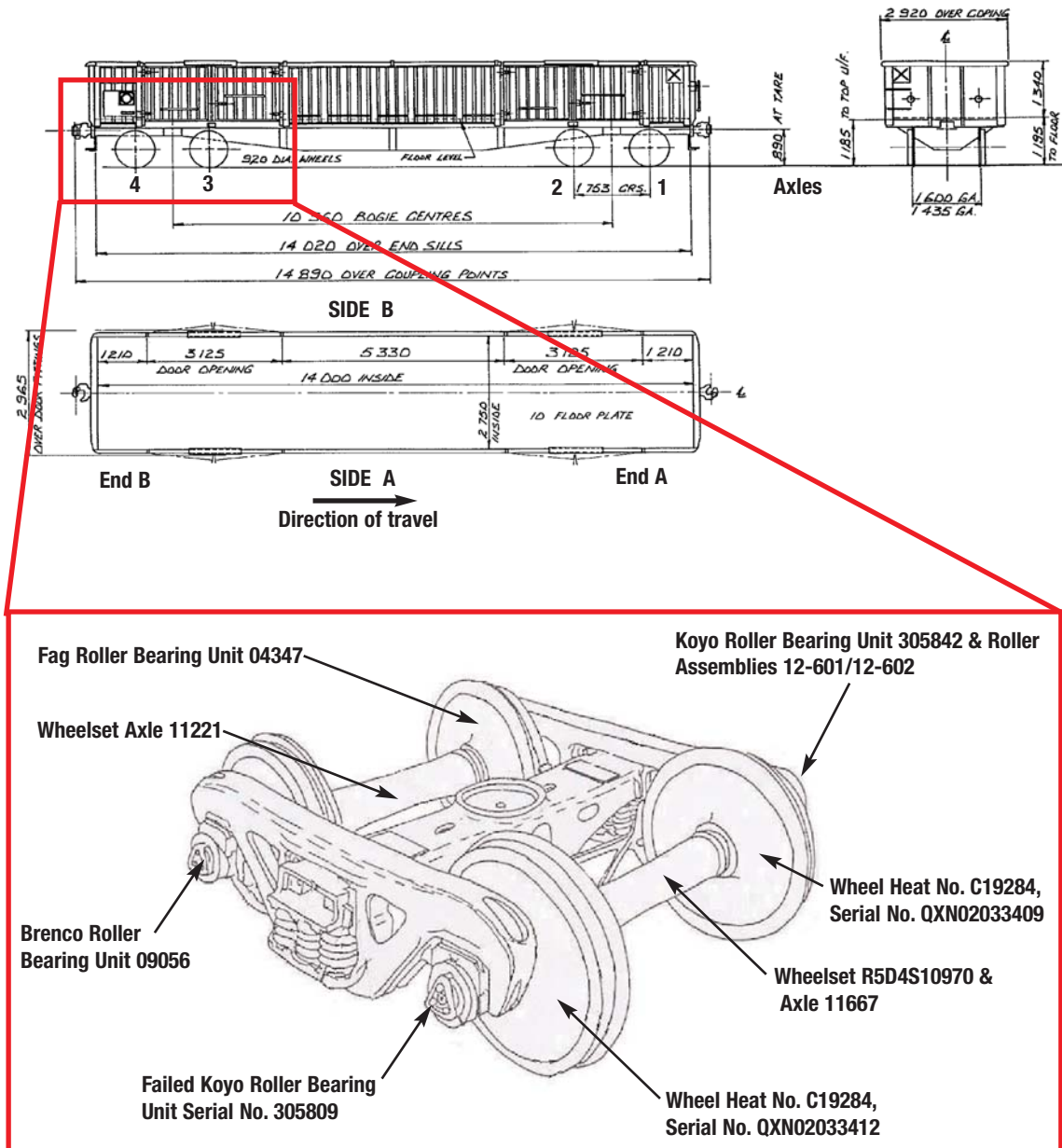

Prior to the incident the wayside detection systems had given the wheel sets and RBUs position identification. The failed RBU number 305809 had a position identification of '3A' and was travelling on the right hand side of the train in direction of travel. (Wagon line diagram by Pacific National, bogie diagram and labelling by the ATSB).

6.2 Bogie, wheel, and failed bearing component details

The bearing, bogie, and wheel details that could be supplied for the investigation are as follows:

Table 9: The components relating to the damaged RBU are marked thus *

Bogie type	Ride Control A3, 50 ton, Standard Gauge
Bogie number	XCW 0125
Bolster number	OH696MT
Side frame numbers	13706* and 13705
Axle numbers	11667* and 11221
Axle stencils	BI6 00 PA^
Wheel numbers	CSC 02 C19284 33409* - CSC 02 C19284 33412 91 20? CSC D0542 B - 91 20? CSC D0542 B
RBU manufacturer's Brands – Outer ring	KOYO HM 127415XD-JAPAN-U-11-96-305809* KOYO HM 127415XD-JAPAN-U-11-96-305842 BRESCO HM 127415XD-USA-L-92-09056 FAG 512952.1-AAR26-USA-L-94-04347
Bearing last overhaul from locking plate	6 00^

Details marked thus: ^ indicate that details were only available for non-damaged RBU axle.

6.3 Bearing unit component details – opposite end to failed RBU

The bearing, bogie, and wheel details that could be supplied for the investigation are as follows:

Table 10: The components relating to the RBU opposite to the damaged RBU

Roller assembly	KOYO JAPAN 11-96 HM 127446 U, 12-601 & 12-602
Seal	KOYO JAPAN 703N50 Class D 11-96 KCR 194
Seal wear ring	
Inboard:	SKF 1637503-13 10-83
Outboard:	FAG-120987/17-USA>J94
Outer ring brands	<KOYO HM 127415XD-JAPAN-U-11-96-305842>
Spacer	KOYO JAPAN HM 127446XA-11-96
Backing ring	RSSS D1015 02
End cap	KOYO 5 ½ x 10 AAR 14 – fitted with grease nipple

6.4 Bearing acoustic monitor data

Each time the wagon passed the system the spectra was captured and was overlaid as illustrated below. Each pass was plotted in a different colour to represent the date the spectrum was captured. The below spectra is a plot of the amplitude of the RBU fault against frequency represented in orders where 1 order is one wheel revolution.

FIGURE 16: The Spectral plot for RKCX24 – RBU location 3A. Shown is the growth in RBU fault type as time progressed against decibel strength. As fault strength is a function of the speed of the RBU, the fault level is normalised against a wagon travelling at 82km/hr (500rpm) and an average wheel diameter of 870mm.

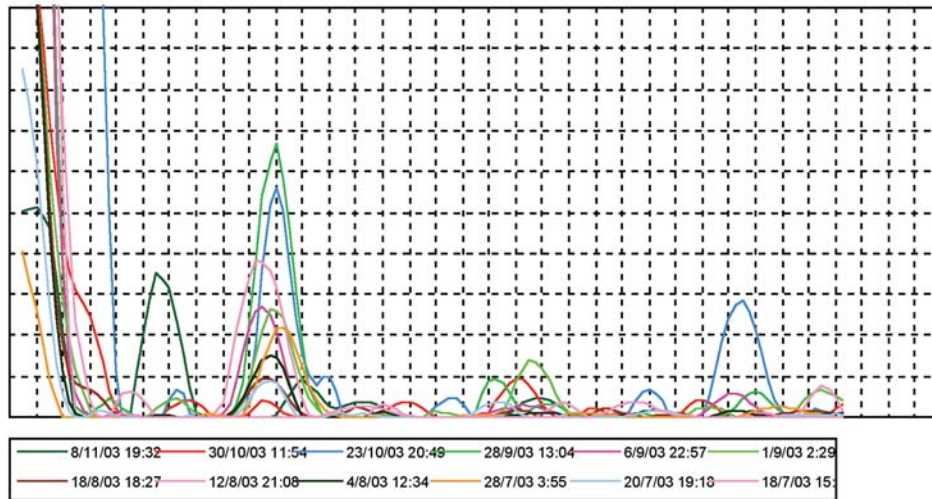

The fault levels have been broken down to represent Low, Medium, and High. These levels are based on pull down results and commissioning results and are individually tailored to each fault type.

FIGURE 17: Fault level readings for RKCX24 – RBU location 3A. Fault levels for CONE, CUP, LOOSENESS, and ROLLERS have been shown as this RBU had elements of the faults in both the RBU which failed and that of the opposite side of wagon RBU in position 3B

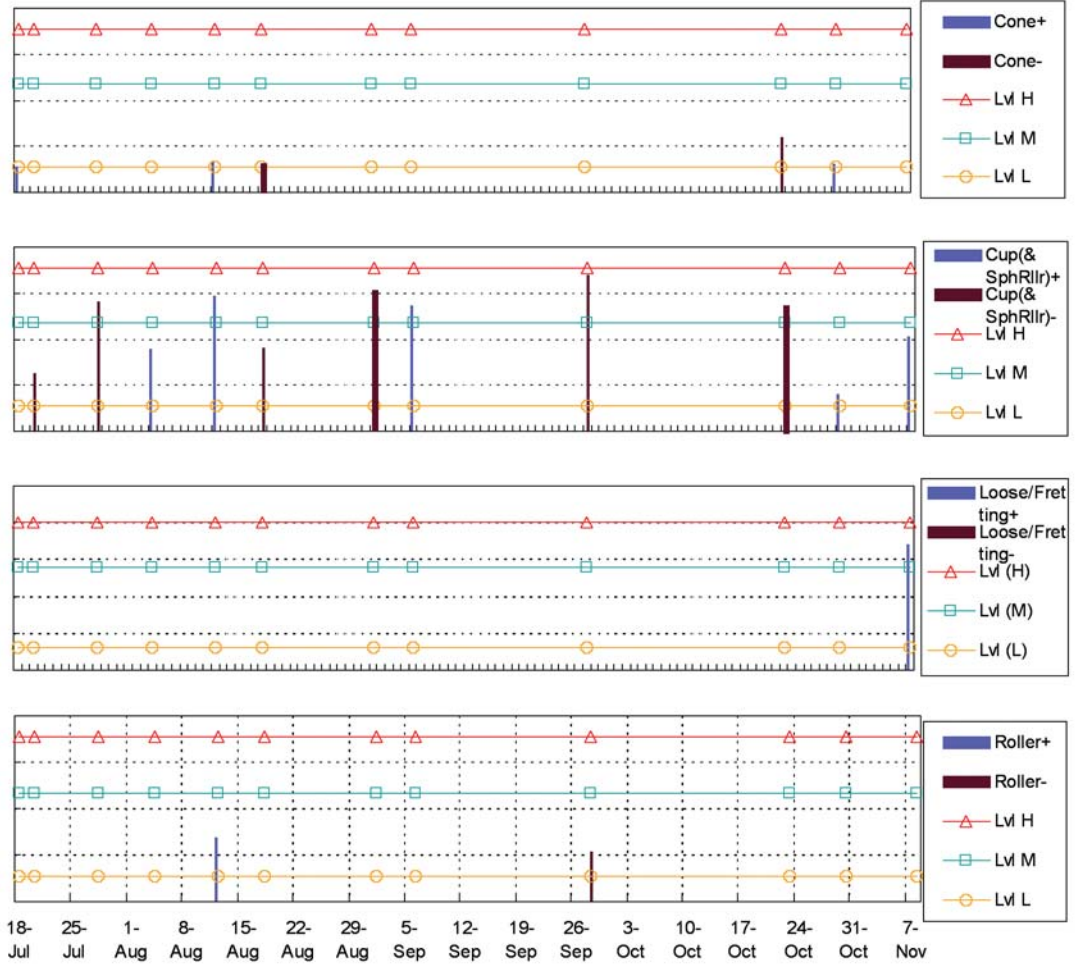

6.5 Bearing acoustic monitor data – opposite RBU

Using the information produced by the system, it has been broken down to give RBU condition analysis.

FIGURE 18. Spectral plot for RKCX 00024 – RBU location 3B

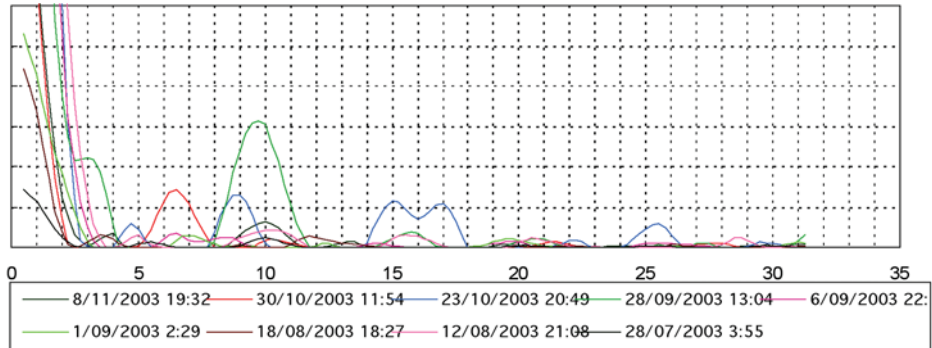
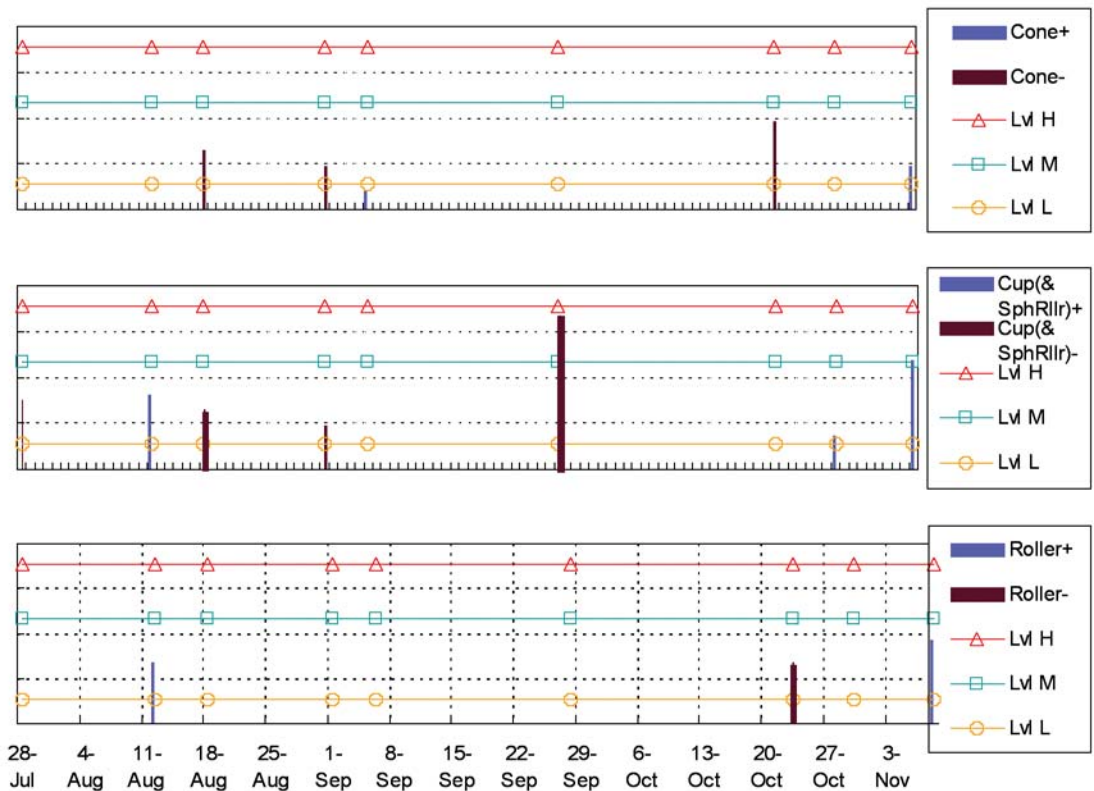

FIGURE 19: Fault level readings for RKCX 00024 – RBU location 3B



Derailement of Train 6WP2

Bates, South Australia, 9 November 2003

1800 621 372

www.atSB.gov.au